

**Agilent 34980A
Multifunction
Switch/Measure Unit**

User's Guide

Notices

© Agilent Technologies, Inc. 2004

No part of this manual may be reproduced in any form or by any means (including electronic storage and retrieval or translation into a foreign language) without prior agreement and written consent from Agilent Technologies, Inc. as governed by United States and international copyright laws.

Manual Part Number

34980-90001

Edition

First edition, November 2004

Printed in Malaysia

Agilent Technologies, Inc.
815 14th Street SW
Loveland, CO 80537 USA

Warranty

The material contained in this document is provided “as is,” and is subject to being changed, without notice, in future editions. Further, to the maximum extent permitted by applicable law, Agilent disclaims all warranties, either express or implied, with regard to this manual and any information contained herein, including but not limited to the implied warranties of merchantability and fitness for a particular purpose. Agilent shall not be liable for errors or for incidental or consequential damages in connection with the furnishing, use, or performance of this document or of any information contained herein. Should Agilent and the user have a separate written agreement with warranty terms covering the material in this document that conflict with these terms, the warranty terms in the separate agreement shall control.

Technology Licenses

The hardware and/or software described in this document are furnished under a license and may be used or copied only in accordance with the terms of such license.

Restricted Rights Legend

If software is for use in the performance of a U.S. Government prime contract or sub-contract, Software is delivered and licensed as “Commercial computer software” as defined in DFAR 252.227-7014 (June 1995), or as a “commercial item” as defined in FAR 2.101(a) or as “Restricted computer software” as defined in FAR 52.227-19 (June 1987) or any equivalent

agency regulation or contract clause. Use, duplication or disclosure of Software is subject to Agilent Technologies’ standard commercial license terms, and non-DOD Departments and Agencies of the U.S. Government will receive no greater than Restricted Rights as defined in FAR 52.227-19(c)(1-2) (June 1987). U.S. Government users will receive no greater than Limited Rights as defined in FAR 52.227-14 (June 1987) or DFAR 252.227-7015 (b)(2) (November 1995), as applicable in any technical data.

Safety Notices

CAUTION

A **CAUTION** notice denotes a hazard. It calls attention to an operating procedure, practice, or the like that, if not correctly performed or adhered to, could result in damage to the product or loss of important data. Do not proceed beyond a **CAUTION** notice until the indicated conditions are fully understood and met.

WARNING

A **WARNING** notice denotes a hazard. It calls attention to an operating procedure, practice, or the like that, if not correctly performed or adhered to, could result in personal injury or death. Do not proceed beyond a **WARNING** notice until the indicated conditions are fully understood and met.

Additional Safety Notices

The following general safety precautions must be observed during all phases of operation of this instrument. Failure to comply with these precautions or with specific warnings or instructions elsewhere in this manual violates safety standards of design, manufacture, and intended use of the instrument. Agilent Technologies assumes no liability of the customer's failure to comply with the requirements.

General

Do not use this products in any manner not specified by the manufacturer. The protective features of this product may be impaired if it is used in a manner not specified in the operation instructions.

Before Applying Power

Verify that all safety precautions are taken. Make all connections to the unit before applying power.

Ground the Instrument

This product is provided with protective earth terminals. To minimize shock hazard, the instrument must be connected to the ac power mains through a grounded power cable, with the ground wire firmly connected to an electrical ground (safety ground) at the power outlet. Any interruption of the protective (grounding) conductor or disconnection of the protective earth terminal will cause a potential shock hazard that could result in personal injury.

Do Not Operate in an Explosive Atmosphere

Do not operate the instrument in the presence of flammable gases or fumes.

Do Not Remove the Instrument Cover

Only qualified, service-trained personal who are aware of the hazards involved should remove instrument covers. Always disconnect the power cable and any external circuits before removing the instrument cover.

Do Not Modify the Instrument

Do not install substitute parts or perform any unauthorized modification to the product. Return the product to an Agilent Sales and Service Office for service and repair to ensure that safety features are maintained.

In Case of Damage

Instruments that appear damaged or defective should be made inoperative and secured against unintended operation until they can be repaired by qualified service personnel.

Safety Symbols



Alternating current



Frame or chassis terminal



Standby supply. Unit is not completely disconnected from ac mains when switch is off



Caution, risk of electric shock



Caution, refer to accompanying description

If you have questions about your shipment, or if you need information about warranty, service, or technical support, contact Agilent Technologies:

In the United States: (800) 829-4444

In Europe: 31 20 547 2111

In Japan: 0120-421-345

Or go to www.agilent.com/find/assist for information on contacting Agilent in your country of specific location. You can also contact your Agilent Technologies Representative.



Manufacturer's Name: Agilent Technologies, Incorporated
Manufacturer's Address: 815 – 14th St. SW
Loveland, CO 80537
USA

Declares under sole responsibility that the product as originally delivered

Product Name: Multifunction Switch / Measure Unit
Model Number: 34980A, 34921A/T, 34922A/T, 34923A/T, 34925A/T,
34931A/T, 34932A/T, 34933A/T, 34937A/T, 34938A/T,
34941A, 34946A, 34947A, 34951A/T, 34952A/T
Product Options: This declaration covers all options of the above products

complies with the essential requirements of the following applicable European Directives, and carries the CE marking accordingly:

Low Voltage Directive (73/23/EEC, amended by 93/68/EEC)
EMC Directive (89/336/EEC, amended by 93/68/EEC)

and conforms with the following product standards:

EMC	Standard	Limit
	IEC 61326-1:1997+A1:1998 / EN 61326-1:1997+A1:1998	
	CISPR 11:1990 / EN 55011:1991	Group 1 Class A
	IEC 61000-4-2:1995+A1:1998 / EN 61000-4-2:1995	4 kV CD, 4 kV AD
	IEC 61000-4-3:1995 / EN 61000-4-3:1995	3 V/m, 80-1000 MHz
	IEC 61000-4-4:1995 / EN 61000-4-4:1995	0.5 kV signal lines, 1 kV power lines
	IEC 61000-4-5:1995 / EN 61000-4-5:1995	0.5 kV line-line, 1 kV line-ground
	IEC 61000-4-6:1996 / EN 61000-4-6:1996	3 V, 0.15-80 MHz, 80% mod
	IEC 61000-4-11:1994 / EN 61000-4-11:1994	Interrupt: 10 ms, 20 ms
	Canada: ICES-001:1998	
	Australia/New Zealand: AS/NZS 2064.1	

The product was tested in a typical configuration with Agilent Technologies test systems.

Safety IEC 61010-1:2001 / EN 61010-1:2001
Canada: CSA C22.2 No. 61010.1:2004
USA: UL 61010-1: 2004

Supplementary Information:

This DoC applies to above-listed products placed on the EU market after:

9 November 2004

Date

Ray Corson

Product Regulations Program Manager

For further information, please contact your local Agilent Technologies sales office, agent or distributor, or Agilent Technologies Deutschland GmbH, Herrenberger Straße 130, D 71034 Böblingen, Germany.

Contents

1 Introduction to the 34980A

Front Panel at a Glance	2
Rear Panel at a Glance	3
Rear Panel Connector Pinouts	4
External Trigger Input Connector (Male D-Sub)	4
Analog Bus Connector (Female D-Sub)	4
Annunciator Display Indicators	5
Front Panel Menu Reference	6
Instrument Rack Mounting	7

2 Features and Functions

SCPI Language Conventions	10
Rules for Using a Channel List	10
General Measurement Configuration	12
Overview of Measurement Modes	12
Analog Buses	15
Measurement Functions	16
Measurement Range	17
Measurement Resolution	18
Custom A/D Integration Time	19
Autozero	21
Trigger Delay	22
Automatic Trigger Delays	23
Safety Interlock	24
User-Defined Channel Labels	25
2-Wire Versus 1-Wire Mode	27
Analog Bus and Internal DMM Considerations	28
Environmental Operating Conditions	28
Electrical Operating Conditions	29

Temperature Measurement Configuration	30
Measurement Units	30
Thermocouple Measurements	31
RTD Measurements	33
Thermistor Measurements	34
Voltage Measurement Configuration	35
DC Input Resistance	35
AC Low Frequency Filter	36
Resistance Measurement Configuration	37
Offset Compensation	37
Current Measurement Configuration	38
AC Low Frequency Filter	38
Frequency Measurement Configuration	39
Low Frequency Timeout	39
Mx+B Scaling	40
Scanning	42
Rules for Scanning	42
Adding Channels to the Scan List	44
Scan Trigger Source	46
Trigger Count	49
Sweep Count	50
Sample Count	51
Channel Delay	53
Automatic Channel Delays	54
Reading Format	56
Non-Sequential Scanning	57
Viewing Readings Stored in Memory	58
Monitor Mode	60

System-Related Operations	62
Firmware Revision	62
Product Firmware Updates	63
Instrument State Storage	63
Error Conditions	64
Self-Test	66
Front-Panel Display Control	66
Front-Panel Number Format	67
Real-Time System Clock	68
Relay Cycle Count	68
SCPI Language Version	69
Calibration Overview	70
Calibration Security	70
Calibration Count	72
Calibration Message	73
Remote Interface Configuration	74
GPIB Interface	75
USB Interface	75
LAN Interface	75
Factory Reset State	84
Instrument Preset State	86

3 Introduction to the Plug-In Modules for the 34980A

Slot and Channel Addressing Scheme	90
Interconnection Solutions Overview	91
Module Considerations	92
General Considerations	92
Environmental Operating Conditions	92
Electrical Operating Conditions	93

4 Low Frequency Multiplexer Switch Modules

Low Frequency Multiplexer Switch Modules	96
Measurement Functions for the MUX Modules	97
SCPI Programming Examples for the MUX Modules	98
34921A 40-Channel Armature Multiplexer with Low Thermal Offset	102
34921A Simplified Schematic	104
34921A D-Sub Connectors	105
34921T Terminal Block	106
34922A 70-Channel Armature Multiplexer	107
34922A Simplified Schematic	108
34922A D-Sub Connectors	109
34922T Terminal Block	111
34923A 40/80-Channel Reed Multiplexer	112
34923A Simplified Schematic for Two- or Four-Wire Mode	114
34923A D-Sub Connectors for Two- or Four-Wire Mode	116
34923T-001 Terminal Block for Two- or Four-Wire Mode	117
34923A Simplified Schematic for One-Wire Mode	118
34923A D-Sub Connectors for One-Wire Mode	119
34923T-002 Terminal Block for One-Wire Mode	120
34924A 70-Channel Reed Multiplexer	121
34924A Simplified Schematic	123
34924A D-Connectors	124
34924T Terminal Block	126
34925A 40/80-Channel Optically-Isolated FET Multiplexer	127
34925A Simplified Schematic for Two- or Four-Wire Mode	130
34925A D-Sub Connectors for Two- or Four-Wire Mode	131
34925T-001 Terminal Block for Two- or Four-Wire Mode	132
34925A Simplified Schematic for One-Wire Mode	133
34925A D-Sub Connectors for One-Wired Mode	134
34925T-002 Terminal Block for One-Wire Mode	135

5 Matrix Switch Modules

Matrix Switch Modules	138
SCPI Programming Examples for the Matrix Modules	139
Linking Multiple Matrix Modules	142
34931A Dual 4x8 Armature Matrix	144
34931A Simplified Schematic	145
34931A D-Sub Connectors	146
34931T Terminal Block	147
34932A Dual 4x16 Armature Matrix	149
34932A Simplified Schematic	150
34932A D-Sub Connectors	151
34932T Terminal Block	152
34933A Dual/Quad 4x8 Reed Matrix	153
34933A Simplified Schematic for Two-Wire Mode	155
34933A D-Sub Connectors for Two-Wire Mode	156
34933T-001 Terminal Block for Two-Wire Mode	157
34933A Simplified Schematic for One-Wire Mode	159
34933A D-Sub Connectors for One-Wire Mode	160
34933T-002 Terminal Block for One-Wire Mode	161

6 General Purpose Switch Modules

General Purpose Switch Modules	164
34937A and 34938A SCPI Programming Examples	166
34937A 32-Channel GP Switch	168
34937A Simplified Schematic	168
34937A D-Sub Connectors	169
34937T Terminal Block	170
34938A 20-Channel High-Current GP Switch	171
34938A Simplified Schematic	171
34938A D-Sub Connectors	172
34938T Terminal Block	173

7 RF Multiplexer Switch Modules

34941A and 34942A RF Multiplexer Switch Modules	176
Installing SMA Connectors	177
Isolating Connector Banks	177
34941A and 34942A SCPI Programming Examples	178
34941A and 34942A Simplified Schematic	179

8 Dual/Triple Microwave Switch Modules

34946A and 34947A Dual/Triple Microwave Switch Modules	182
34946A and 34947A SCPI Programming Examples	182
Installing SMA Connectors	183
34946A and 34947A Simplified Schematics	184

9 4-Channel Isolated D/A Converter with Waveform Memory Module

34951A 4-Channel Isolated D/A Converter with Waveform Memory Module	186
34951A SCPI Programming Examples	189
34951A Simplified Schematics	193
34951A D-Sub Connector Pinout	194
34951T Terminal Block	195

10 Multifunction Module with DIO, D/A, and Totalizer

34952A Multifunction Module	198
Digital Input/Output	198
Totalizer Input	198
Analog Output (DAC)	198
34952A SCPI Programming Examples	199
34952A Simplified Schematic	201
34952 D-Sub Connector	202
34952T Terminal Block	203

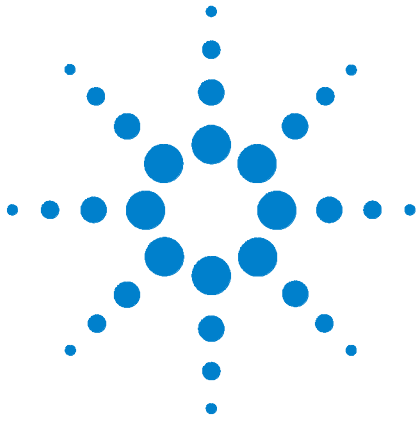

1 Introduction to the 34980A

Front Panel at a Glance	2
Rear Panel at a Glance	3
Rear Panel Connector Pinouts	4
Annunciator Display Indicators	5
Front Panel Menu Reference	6
Instrument Rack Mounting	7

Front Panel at a Glance

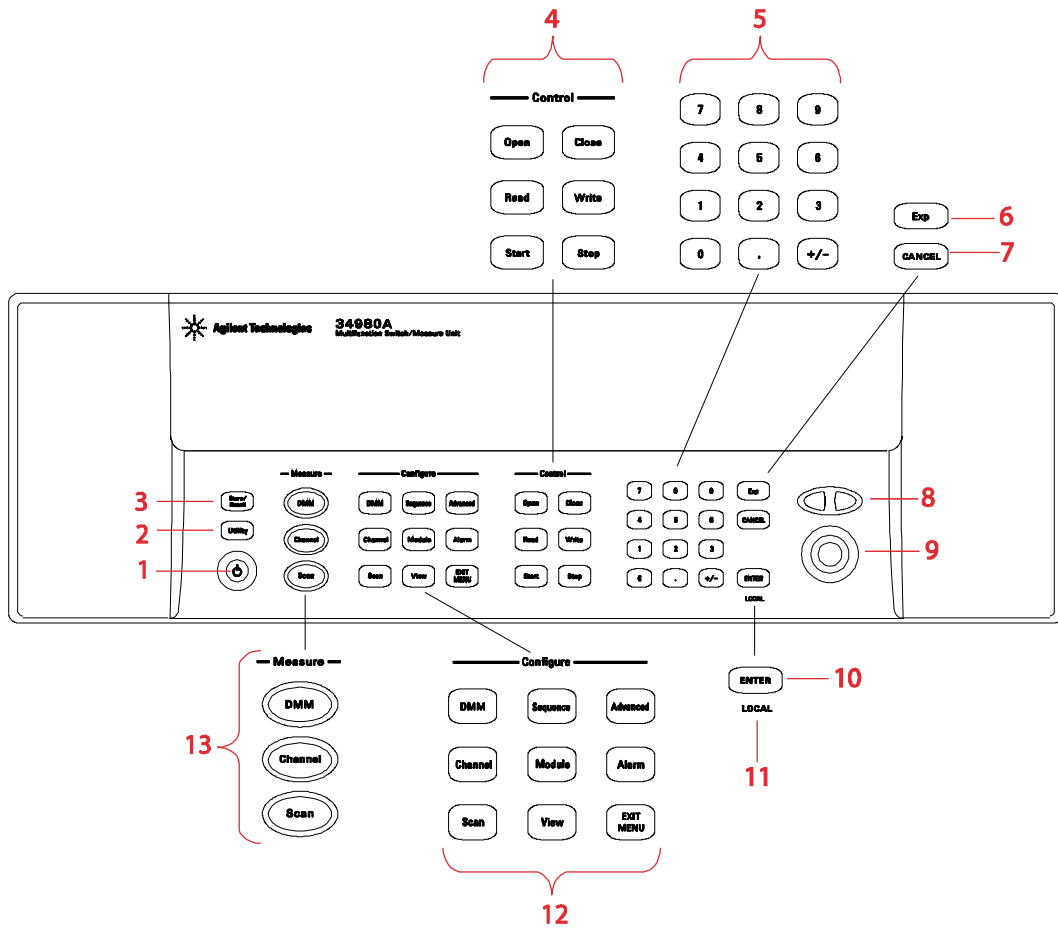

- 1 On/Standby switch **WARNING** This switch is standby only. To disconnect the mains from the instrument, remove the power cord.
- 2 Utility menu contains settings for Remote I/O (LAN, GPIB, and USB), Date and Time, and other system-related instrument parameters
- 3 Store/recall menu allows you to save and recall up to six instrument setups
- 4 Control keys directly control module actions
- 5 Number keypad enters numerical characters
- 6 Exponent
- 7 Cancel key exits a menu without saving changes
- 8 Arrow keys move cursor positions
- 9 Knob enters alphanumeric characters, selects slots, channels, and navigates menus
- 10 Enter key steps you through a menu or saves number entries
- 11 Running a program puts the display into "remote" and disables the front panel keys. Local takes you out of "remote" mode and enables the front panel keys.
- 12 Configure keys select functions and set function parameters
- 13 Measure keys execute and monitor measurements. Depending on which measurement key you use, you can have complete/direct control over the switching and measurement operation, or you can have the 34980A automatically control these to capture the desired data.

Rear Panel at a Glance

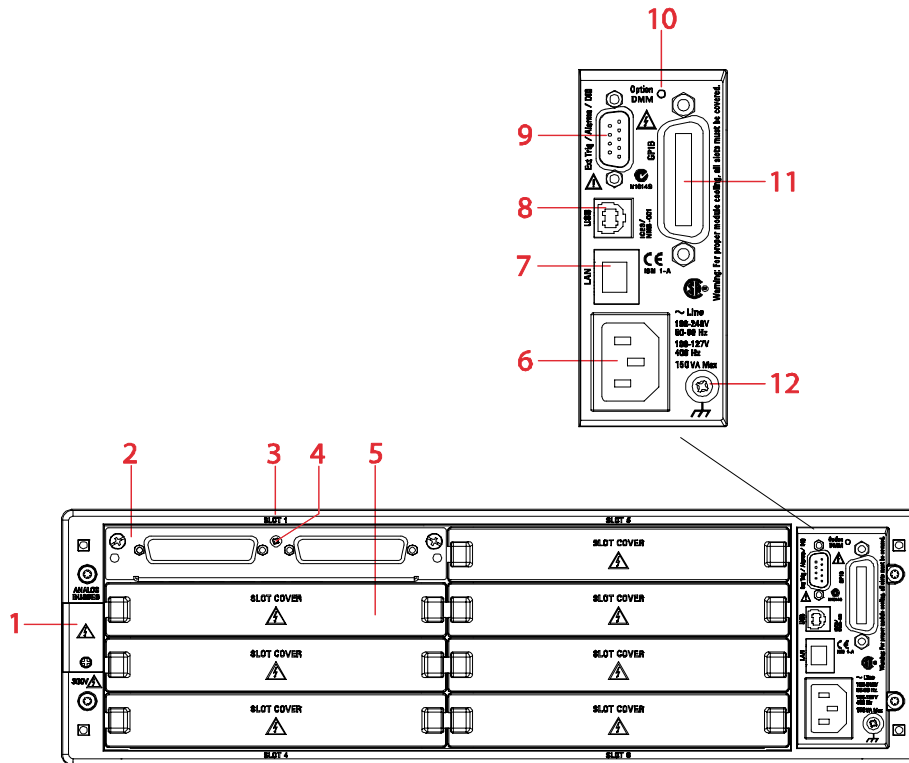

- 1 Access to Analog Buses (shown with cover installed). For pinout, see [page 4](#).
- 2 Module installed in slot 1
- 3 Slot identifier
- 4 Module ground screw
- 5 Slot cover over slot 2
- 6 AC power connector
- 7 LAN connector (10Base T/100Base Tx)
- 8 USB 2.0 connector
- 9 External trigger input. For pinout, see [page 4](#).
- 10 Internal DMM option mark. If you ordered the internal DMM option, the circle is marked black.
- 11 IEEE 488.2 GPIB Connector
- 12 Chassis ground screw

Rear Panel Connector Pinouts

External Trigger Input Connector (Male D-Sub)

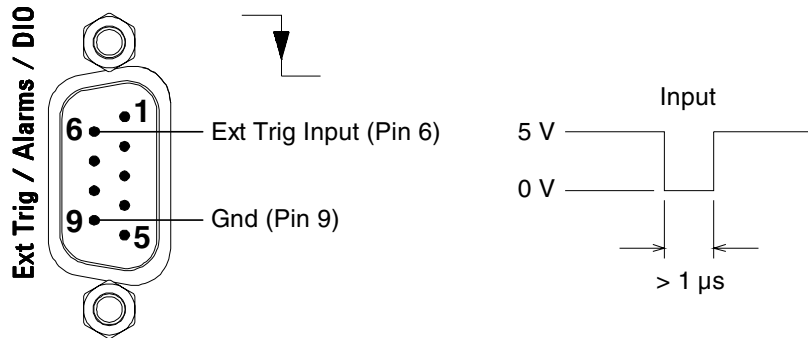

Analog Bus Connector (Female D-Sub)

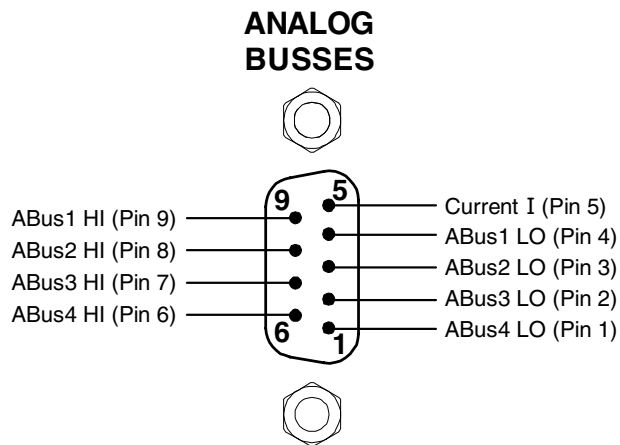

Annunciator Display Indicators

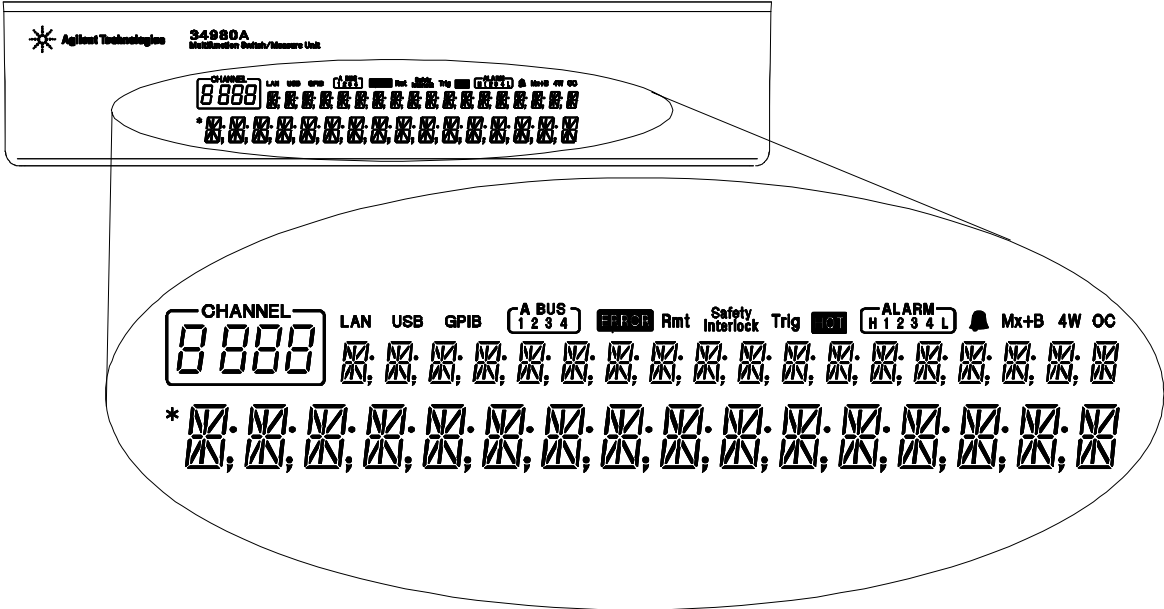

Display Indicator	Definition
LAN	Communicating with the 34980A over LAN
USB	Communicating with the 34980A over USB
GPIB	Communicating with the 34980A over GPIB
ABUS [1234]	Analog Bus Connectivity. Normally, designated ABus connected on any module in mainframe. During scan, if ABus 1 and ABus 2 are indicated, they will be used at some point during the scan
ERROR	An error has been generated and is in the error queue
Rmt	Remote. Running a program puts the display into "remote" and disables the front panel keys. Pressing the LOCAL button takes you out of "remote" mode and enables the front panel keys.
Safety Interlock	ABus safety interlock. Terminal block or cables have been removed from the D-sub connector of a module. For more information, see page 96 and page 138 .
Trig	Waiting for external or manual trigger during scans
HOT	Over-temperature condition. One or more general purpose (34937A/34938A) modules have reached their over-temperature limits.
ALARM (H1234L)	Additional functionality to be implemented
Bell Symbol	Additional functionality to be implemented
Mx+B	Scaling enabled on channel. This appears on display after you select scaling function via front panel or remote interface
4W	4-wire measurement specified on channel. This appears on display after you select the 4-wire function via the front panel or remote interface.
OC	Offset Compensation specified on channel. This appears on display after you have selected the offset compensation function via the front panel or remote interface.
* (left side of display)	Measurement is in progress

Front Panel Menu Reference

This section gives an overview of the top two levels of menus that you access from the front panel. The menus are designed to automatically guide you through all parameters required to configure a particular function or operation.

Store/Recall Store and recall instrument states

- Store up to six instrument states in non-volatile memory
- Assign a name to each storage location.
- Recall stored states, power-down state, factory reset state, or preset state

Utility Configure system-related instrument parameters

- Connecting and configuring to use with LAN, GPIB, or USB
- Set the real time clock and calendar
- Set radix character, thousand separator
- Enable/disable the internal DMM
- Secure/unsecure the instrument for calibration
- Query and update the firmware revisions for the mainframe and modules

Configure Key Group Set parameters for measurement

DMM

- Set DMM measurement function (AC volts, DC volts, AC current, DC current, 2-wire ohms, 4-wire ohms, temperature, frequency, and period)
- Set function parameters

Channel

- Set channel measurement function (AC volts, DC volts, AC current (34921A only), DC current (34921A only) 2-wire ohms, 4-wire ohms, temperature, frequency, and period)
- Set function parameters

Scan

- Set up trigger-in parameters
- Set up sweep count
- Set up sample count

Sequences

Available at a later firmware release

Module

- Open all relays
 - Clear all measurement functions
 - Clear channel labels
 - Configure external trigger and clock (34951A)
 - Set trace or level mode (34951A)
 - Set waveform parameters (34951A)
-

View

- View readings, alarms, and errors
- View the scanned readings from memory
- View errors in the error queue
- Read the number of cycles for the displayed relay (relay maintenance feature).

Advanced

Available at a later firmware release

Alarm

Available at a later firmware release

Instrument Rack Mounting

Using the optional Agilent Y1130A Rack Mount Kit, you can mount the 34980A in a standard 19-inch rack cabinet. The kit includes hardware and instructions to forward or reverse mount the instrument in a cabinet.

1 Introduction to the 34980A

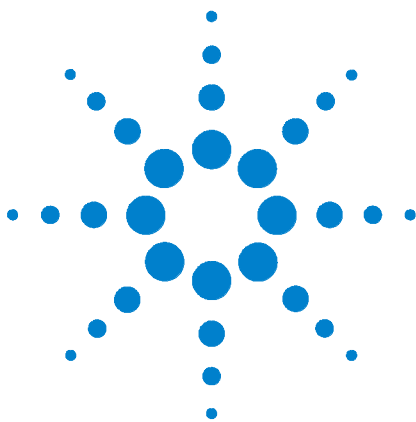

2 Features and Functions

SCPI Language Conventions	10
General Measurement Configuration	12
Analog Bus and Internal DMM Considerations	28
Temperature Measurement Configuration	30
Voltage Measurement Configuration	35
Resistance Measurement Configuration	37
Current Measurement Configuration	38
Frequency Measurement Configuration	39
Mx+B Scaling	40
Scanning	42
Monitor Mode	60
System-Related Operations	62
Calibration Overview	70
Remote Interface Configuration	74
Factory Reset State	84
Instrument Preset State	86

You will find that this chapter makes it easy to look up all the details about a particular feature of the Agilent 34980A. Whether you are operating the instrument from the front panel or over the remote interface, this chapter will be useful. For information specific to the 34980A plug-in modules, see the later chapters in this manual.

NOTE

For complete details on the SCPI (Standard Commands for Programmable Instruments) commands, see the *Programmer's Reference* Help file included on the Agilent 34980A *Product Reference CD-ROM*. The CD-ROM is located inside the rear cover of this manual.



SCPI Language Conventions

Throughout this guide, the following conventions are used for SCPI command syntax for remote interface programming:

- Braces ({ }) enclose the parameter choices for a given command string. The braces are not sent with the command string.
- A vertical bar (|) separates multiple parameter choices for a given command string.
- Triangle brackets (< >) indicate that you must specify a value for the enclosed parameter. The brackets are not sent with the command string.
- Some parameters are enclosed in square brackets ([]). This indicates that the parameter is optional and can be omitted. The brackets are not sent with the command string. If you do not specify a value for an optional parameter, the instrument chooses a default value.

Rules for Using a Channel List

Many of the SCPI commands for the 34980A include a *channel list* parameter which allows you to specify one or more channels. From the remote interface, the channel number has the form (@**sccc**), where **s** is the mainframe slot number (1 through 8) and **ccc** is the channel number. You can specify a single channel, multiple channels, or a range of channels.

The following command closes channel 10 on the module in slot 3.

```
ROUT:CLOS (@3010)
```

The following command closes channels 10, 12, and 15 on the module in slot 2.

```
ROUT:CLOS (@2010,2012,2015)
```

The following command closes channels 5 through 10 (slot 1) and channel 15 (slot 2). When you specify a range of channels, any channels that are invalid will be ignored (no error will be generated) but the first and last channel in the range must be valid.

```
ROUT:CLOS (@1005:1010,2015)
```

The Analog Bus relays (numbered **s911**, **s912**, **s913**, etc.) on the multiplexer and matrix modules are ignored if they are included in a range of channels. An error will be generated if an Analog Bus relay is specified as the first or last channel in a range of channels. For example, the following command closes all valid channels between channel 30 (slot 1) and channel 5 (slot 2). In addition, this command closes Analog Bus relay 911 on the module in slot 1 (Bank 1). Note that although the specified range of channels includes the other Analog Bus relays, they are ignored and are not closed by this command.

```
ROUT:CLOS (@1030:2005,1911)
```

The following command will generate an error since the Analog Bus relays cannot be specified as the first or last channel in a range of channels (none of the channels will be closed).

```
ROUT:CLOS (@1005:1911) !Generates an error
```

In the following command, since the optional `<ch_list>` parameter is omitted, the command will be applied to the internal DMM. If the internal DMM is disabled or is not present, an error will be generated.

```
INP:IMP:AUTO ON !Applies to the internal DMM
```

General Measurement Configuration

This section contains general information to help you configure the instrument for making measurements. Since these parameters are used by several measurement functions, the discussion is combined into one common section. Refer to the later sections in this chapter for more information on parameters that are specific to each measurement function.

Overview of Measurement Modes

Two modes of operation are available with the 34980A, depending on the level of switching and measurement that you wish to directly control: the *Stand-Alone DMM Mode* and the *Scanning Mode*.

Stand-Alone DMM Mode

In the Stand-Alone DMM Mode, the internal DMM makes measurements of whatever signals are present on the Analog Buses. In this mode, you have full control of what channel relays are closed and connected to the appropriate Analog Bus for the measurement. You can route your signals directly to the internal DMM using the 34980A multiplexer and matrix modules, or you can connect to external signals via the *Analog Bus* connector located on instrument's rear panel (see "[Analog Buses](#)" on page 15).

Front Panel Operation:

- To configure the most common measurement parameters for the internal DMM, use the DMM (Configure) key.
- To close the desired channel relays and Analog Bus relays, use the Close key. The Analog Bus relays on the multiplexer and matrix modules are numbered **s911**, **s912**, **s913**, etc.
- To auto-trigger the internal DMM and display continuous readings, press the DMM (Measure) key. Press the DMM (Measure) key again to stop taking measurements.
- For additional triggering control and to store DMM readings in memory, use the Scan (Configure) key to set the triggering parameters, and then press and hold the Scan (Measure) key to initiate the DMM measurement. These selections are available only for stand-alone DMM use when a scan list has not been defined (see "[Stand-Alone DMM Mode](#)" on page 12).
- To stop storing readings in memory during long measurements, press and hold the Scan (Measure) key.

- To view the readings in memory, use the View key (the readings are not erased when you read them). Each time you initiate a new DMM-only scan, the instrument will clear the previous set of readings from memory.

Remote Interface Operation:

- You can use the MEASure? command without specifying a <ch_list> to quickly take a stand-alone DMM reading. Note, however, that with the MEASure? command, most measurement parameters are set to their default values.
- To close the desired channel relays and Analog Bus relays, use the ROUTe:CLOSE command. The Analog Bus relays on the multiplexer and matrix modules are numbered s911, s912, s913, etc.
- To directly control all measurement parameters or triggering, use the CONFigure, SENSE, and TRIGger commands without specifying a <ch_list> parameter. To initiate the measurement, use the INITiate or READ? command without specifying a <ch_list>. Each time you initiate a new measurement, the instrument will clear the previous set of readings from memory.
- To stop a measurement in progress, use the ABORT command.
- To view the readings in memory, use the FETCh? command (the readings are not erased when you read them).

Scanning Mode

In the Scanning Mode, the 34980A automatically controls a sequence of measurements using the internal DMM, possibly across multiple channels, and stores the results in memory. The 34980A closes and opens the appropriate channel relays and Analog Bus relays required for the sequence. The following general rules apply to the Scanning Mode (for more information on using the Scanning Mode, see “Scanning” on page 42.)

- Any channel that can be “read” by the instrument can also be included in a scan. A scan can also include a read of a digital channel or a read of the totalizer count on the digital modules.
- Before you can initiate a scan, you must set up a scan list to include all desired multiplexer or digital channels. Channels which are not in the scan list are skipped during the scan.
- The Analog Bus relays are automatically opened and closed as required during the scan to connect to the internal DMM for the measurement. For example, all 2-wire measurements use the ABus1 (MEAS) relays; for 4-wire measurements, the ABus2 (SENS) relays are used in addition to the ABus1 relays.
- Each time you initiate a new scan, the instrument will clear the previous set of readings from memory.

Front Panel Operation:

- To configure the measurement parameters and add a channel to the scan list, use the Channel (Configure) key.
- To initiate a scan and store all readings in memory, press the Scan (Measure) key. If you press the Scan (Measure) key with no scan list defined, the instrument initiates a DMM-only measurement (see “Stand-Alone DMM Mode” below).
- To stop a scan in progress, press and hold the Scan (Measure) key.
- To view the readings in memory, use the View key (the readings are not erased when you read them).

Remote Interface Operation:

- To define the list of channels to be included in the scan list, use the ROUTe:SCAN command.
- To configure the measurement parameters on the desired channels, use the CONFigure and SENSE commands.
- To initiate a scan and store all readings in memory, use the INITiate or READ? command. Each time you initiate a new scan, the instrument will clear the previous set of readings from memory.
- To stop a scan in progress, use the ABORT command.
- To view the readings in memory, use the FETCh? command (the readings are not erased when you read them).

NOTE

You can use the READ? command in one of three forms depending on which measurement mode you wish to use.

- If you omit the optional <ch_list> parameter and a scan list is not currently defined, the READ? command applies to the internal DMM.
- If you omit the optional <ch_list> parameter and a scan list is currently defined, the READ? command performs a scan of the channels in the scan list.
- If you specify a <ch_list>, regardless of whether a scan list is currently defined, the READ? command performs a “temporary” scan of the specified channels (independent of the present scan list).

NOTE

You can use the MEASure? command in one of two forms depending on which measurement mode you wish to use.

- If you omit the optional <ch_list> parameter, the MEASure? command applies to the internal DMM.
- If you specify a <ch_list>, the MEASure? command performs a “temporary” scan of the specified channels (independent of the present scan list).

Analog Buses

The 34980A provides four 2-wire internal Analog Buses for easier signal routing. You can route your measurements directly to the internal DMM using the 34980A multiplexer and matrix modules, or you can connect to external signals via the *Analog Bus* connector located on the instrument's rear panel (see connector pinout below). Since four 2-wire buses are provided, you can dedicate one bus for use with the internal DMM and use the other three buses for module extensions or additional signal routing between modules.

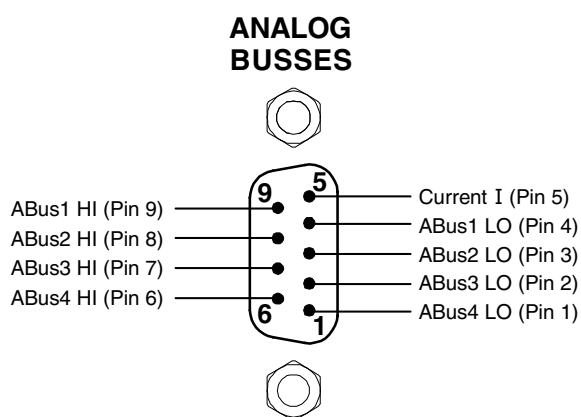

Analog Bus connector (as viewed from rear of instrument)

Measurement Functions

The following table shows which DMM measurement functions are supported by each of the multiplexer modules.

Note that similar considerations must be taken into account on the 34931A, 34932A, and 34933A matrix modules. Since the matrix modules cannot be incorporated into a scan list, you must use the Stand-Alone DMM Mode for these modules.

Function	34921A 40-Ch Arm MUX	34922A 70-Ch Arm MUX	34923A 40-Ch Reed MUX (2-Wire)	34923A 80-Ch Reed MUX (1-Wire)	34924A 70-Ch Reed MUX	34925A 40-Ch FET MUX (2-Wire)	34925A 80-Ch FET MUX (1-Wire)
Voltage, AC/DC	Yes	Yes	Yes	Yes	Yes	Yes	Yes
Current, AC/DC	Yes ¹	No	No	No	No	No	No
Frequency/Period	Yes	Yes	Yes	Yes	Yes	Yes	Yes
Ohms 2-Wire	Yes	Yes	Yes ⁵	Yes ⁵	Yes ⁵	Yes ⁶	Yes ⁶
Ohms 4-Wire	Yes	Yes	Yes ⁵	No	Yes ⁵	Yes ⁶	No
Thermocouple	Yes ²	Yes ³	Yes ^{3,4}	Yes ^{3,4}	Yes ^{3,4}	Yes ³	Yes ³
RTD 2-Wire	Yes	Yes	Yes ⁵	Yes ⁵	Yes ⁵	No	No
RTD 4-Wire	Yes	Yes	Yes ⁵	No	Yes ⁵	Yes ⁶	No
Thermistor	Yes	Yes	Yes ⁵	Yes ⁵	Yes ⁵	No	No

¹ Direct current measurements are allowed on channels 41 through 44 only (for all other channels, external shunts are required).

² Optional 34921T Terminal Block is required for thermocouple measurements with built-in internal reference junction.

³ A fixed or external reference junction temperature is required for thermocouple measurement with this module.

⁴ Impact of higher offset voltage specification (< 50 μ V) must be taken into consideration.

⁵ 1 k Ω or higher range used unless 100 Ω series resistors are bypassed on module.

⁶ 10 k Ω or higher range used for loads over approximately 300 Ω due to series resistance of FET channels.

Front Panel Operation: DMM or Channel (Configure) > DMM MEASUREMENT

Use the knob (or numeric keypad) to select the desired channel. Then select the desired measurement function for this channel. You are automatically guided to the next level of the menu where you can configure other measurement parameters (range, integration time, etc.).

Remote Interface Operation: You can select the measurement function using the CONFIGure and MEASure? commands. For example, the following command configures the specified channel for dc voltage measurements.

```
CONF:VOLT:DC 10,DEF,(@3001)
```

Measurement Range

You can allow the instrument to automatically select the measurement range using *autoranging* or you can select a fixed range using *manual ranging*. Autoranging is convenient because the instrument decides which range to use for each measurement based on the input signal. For fastest scanning operation, use manual ranging on each measurement (some additional time is required for autoranging since the instrument has to make a range selection).

- Autorange thresholds:
 - Down range at: <10% of range
 - Up range at: >120% of range
- If the input signal is greater than can be measured on the selected range (manual ranging), the instrument gives an overload indication: “±OVL” from the front panel or “±9.9E+37” from the remote interface.
- For temperature measurements, the instrument internally selects the range; you cannot select which range is used. For thermocouple measurements, the instrument internally selects the 100 mV range. For thermistor and RTD measurements, the instrument autoranges to the correct range for the transducer resistance measurement.
- For frequency and period measurements, the instrument uses one “range” for all inputs between 3 Hz and 300 kHz. The *range* parameter is required only to specify the resolution. Therefore, it is not necessary to send a new command for each new frequency to be measured.
- The CONFigure and MEASure? commands contain an optional parameter which allows you to specify the range or autoranging.
- The instrument returns to autoranging when the measurement function is changed and after a Factory Reset (*RST command). An Instrument Preset (SYSTEM:PRESet command) or Card Reset (SYSTEM:CPON command) does *not* change the range setting.

Front Panel Operation: DMM or Channel (Configure) > RANGE

First, select the measurement function on the active channel. You are automatically guided to the next level of the menu where you can select a specific range or autoranging.

Remote Interface Operation: You can select the range using parameters in the CONFigure and MEASure? commands. For example, the following command selects the 10 Vdc range on the specified channel.

```
CONF:VOLT:DC 10,DEF,(@3001)
```

Measurement Resolution

Resolution is expressed in *number of digits* the internal DMM can measure or display on the front panel. You can set the resolution to 4, 5, or 6 full digits, plus a “½” digit which can be “0” or “1”. To increase the measurement accuracy and improve noise rejection, select 6½ digits. To increase the measurement speed, select 4½ digits.

- For ac voltage measurements, the resolution is fixed at 6½ digits. The only way to control the reading rate for ac measurements is by changing the channel delay (see [page 53](#)) or by setting the ac filter to the highest frequency limit (see [page 36](#)).
- The specified resolution is used for all measurements on the selected channel. If you have applied Mx+B scaling or have assigned alarms to the selected channel, those measurements are also made using the specified resolution. Measurements taken during the Monitor function also use the specified resolution.
- Changing the number of digits does more than just change the resolution of the instrument. It also changes the *integration time*, which is the period the instrument’s analog-to-digital (A/D) converter samples the input signal for a measurement. See “[Custom A/D Integration Time](#)” on page 19 for more information.
- The CONFigure and MEASure? commands contain an optional parameter which allows you to specify the resolution.
- The instrument returns to 5½ digits when the measurement function is changed and after a Factory Reset (*RST command). An Instrument Preset (SYSTEM:PRESet command) or Card Reset (SYSTEM:CPON command) does *not* change the resolution setting.

Front Panel Operation: DMM or Channel (Configure) > INTEGRATION > NPLC

First, select the measurement function on the active channel. You are automatically guided to the next level of the menu where you can select a specific resolution.

Remote Interface Operation: Specify the resolution in the same units as the measurement function, not in number of digits. For example, if the function is dc voltage, specify the resolution in volts. For frequency, specify the resolution in hertz.

You can select the resolution using parameters in the CONFigure and MEASure? commands. For example, the following command selects the 10 Vdc range with 4½ digits of resolution on the specified channel.

```
CONF:VOLT:DC 10,0.001,(@3001)
```

The following command selects the 1 A range with 6½ digits of resolution on channel 2041 (current measurements are allowed only on channels 41 through 44 on the 34921A).

```
MEAS:CURR:AC? 1,1E-6, (@2041)
```

You can also select the resolution using the SENSE commands. For example, the following command specifies a 2-wire ohms measurement with 100Ω of resolution on channel 1003.

```
SENS:RES:RES 100, (@1003)
```

Custom A/D Integration Time

Integration time is the period of time the internal DMM's analog-to-digital (A/D) converter samples the input signal for a measurement. Integration time affects the measurement resolution (for better resolution, use a longer integration time) and measurement speed (for faster measurements, use a shorter integration time).

- Integration time is specified in number of *power line cycles* (PLCs). Select from 0.02, 0.2, 1, 2, 10, 20, 100, or 200 power line cycles. *The default is 1 PLC.*
- Only integral number of power line cycles (1, 2, 10, 20, 100, or 200 PLCs) provide normal mode (line frequency noise) rejection.
- You can also specify integration time directly in seconds (this is called *aperture time*). Select a value between 300 μs and 1 second, with 4 μs resolution.
- The only way to control the reading rate for ac measurements is by changing the channel delay (see “[Channel Delay](#)” on page 53) or by setting the ac filter to the highest frequency limit (see “[AC Low Frequency Filter](#)” on page 36).
- The specified integration time is used for all measurements on the selected channel. If you have applied Mx+B scaling or have assigned alarms to the selected channel, those measurements are also made using the specified integration time. Measurements taken during the Monitor function also use the specified integration time.

- The following table shows the relationship between integration time, measurement resolution, number of digits, and number of bits.

Relationship between integration time, resolution, digits, and bits

Integration Time	Resolution	Digits	Bits
0.02 PLC	< 0.0001 x Range	4½ Digits	15
0.2 PLC	< 0.00001 x Range	5½ Digits	18
1 PLC	< 0.000003 x Range	5½ Digits	20
2 PLC	< 0.0000022 x Range	6½ Digits	21
10 PLC	< 0.000001 x Range	6½ Digits	24
20 PLC	< 0.0000008 x Range	6½ Digits	25
100 PLC	< 0.0000003 x Range	6½ Digits	26
200 PLC	< 0.00000022 x Range	6½ Digits	26

- The instrument selects 1 PLC when the measurement function is changed and after a Factory Reset (*RST command). An Instrument Preset (SYSTEM:PRESet command) or Card Reset (SYSTEM:CPON command) does *not* change the integration time setting.

Front Panel Operation: DMM or Channel (Configure) > INTEGRATION > TIME

First, select the measurement function on the active channel. You are automatically guided to the next level of the menu where you can select a specific integration time.

Remote Interface Operation: You can set the integration time using the SENSE commands. For example, the following command specifies an aperture time of 2 ms for resistance measurements on channel 2001.

```
SENS:RES:APER 0.002, (@2001)
```

Autozero

When autozero is *enabled* (default), the instrument internally disconnects the input signal following each measurement, and takes a *zero* reading. It then subtracts the zero reading from the preceding reading. This prevents offset voltages present on the instrument's input circuitry from affecting measurement accuracy.

When autozero is *disabled*, the instrument takes one zero reading and subtracts it from all subsequent measurements. It takes a new zero reading each time you change the function, range, or integration time.

- Applies to temperature, dc voltage, resistance, temperature, and dc current measurements only.
- The autozero mode is set indirectly when you set the resolution and integration time. Autozero is automatically turned off when you select an integration time less than 1 PLC.
- The CONFigure and MEASure? commands automatically enable autozero.
- The autozero setting is stored in non-volatile memory, and does not change when power has been off, after a Factory Reset (*RST command), or after an Instrument Preset (SYSTem:PRESet command).

Front Panel Operation: DMM or Channel (Configure) > AUTO ZERO

Remote Interface Operation: The OFF and ONCE parameters have a similar effect. Autozero OFF does *not* issue a new zero measurement. Autozero ONCE issues an immediate zero measurement.

```
[SENSe:]<function>:ZERO:AUTO {OFF|ONCE|ON} [, (@<ch_list>)]
```

Trigger Delay

In some applications, you want to allow the input to settle before taking a reading or for pacing a burst of readings. You can add a *trigger delay*, which adds a delay between the trigger signal and the first sample taken by the internal DMM (not used in Scanning Mode). The programmed trigger delay overrides the default trigger delay that the instrument automatically adds to the measurement.

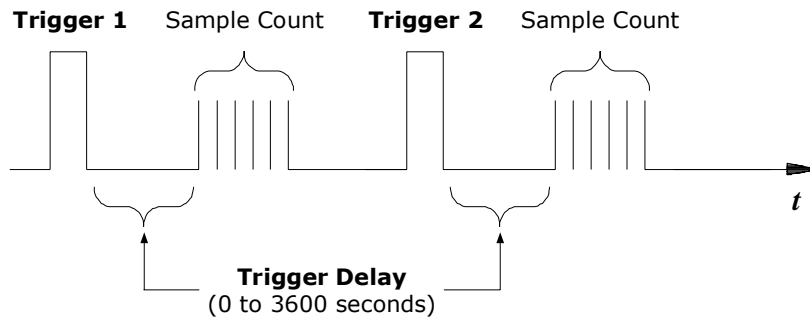

Trigger delay

- The default trigger delay is Automatic (see “[Automatic Trigger Delays](#)” on page 23); the instrument determines the delay based on function, range, and integration time.
- If you specify a trigger delay other than Automatic, that same delay is used for all functions and ranges.
- If you have configured the instrument to take more than one reading per trigger (sample count > 1), the specified trigger delay is inserted between the trigger and the first reading in the sample burst.
- The `CONFigure` and `MEASure?` commands set the trigger delay to Automatic.
- The instrument selects an automatic trigger delay after a Factory Reset (`*RST` command). An Instrument Preset (`SYSTEM:PRESet` command) or Card Reset (`SYSTEM:CPON` command) does *not* change the setting.

Automatic Trigger Delays

If you do not specify a trigger delay, the instrument selects a delay for you. The delay is determined by the function, range, integration time, and ac filter setting as shown below.

DC Voltage, Thermocouple, DC Current (for all ranges):

Integration Time	Trigger Delay
PLC > 1	2.0 ms
PLC ≤ 1	1.0 ms

Resistance, RTD, Thermistor (2- and 4-wire):

Range	Trigger Delay (for PLC > 1)	Range	Trigger Delay (for PLC ≤ 1)
100Ω	2.0 ms	100Ω	1.0 ms
1 kΩ	2.0 ms	1 kΩ	1.0 ms
10 kΩ	2.0 ms	10 kΩ	1.0 ms
100 kΩ	25 ms	100 kΩ	20 ms
1 MΩ	30 ms	1 MΩ	25 ms
10 MΩ	200 ms	10 MΩ	200 ms
100 MΩ	200 ms	100 MΩ	200 ms

AC Voltage, AC Current (for all ranges):

AC Filter	Trigger Delay
Slow (3 Hz)	7.0 seconds
Medium (20 Hz)	1.0 second
Fast (200 Hz)	120 ms

Frequency, Period:

AC Filter	Trigger Delay
Slow (3 Hz)	600 ms
Medium (20 Hz)	300 ms
Fast (200 Hz)	100 ms

Digital Input, Totalize:

Trigger Delay
0 seconds

Safety Interlock

The *Safety Interlock* feature prevents connections to the Analog Buses if no terminal block or properly-wired cable is connected to a module (available on multiplexer and matrix modules only).

Normally, if you attempt to connect to the Analog Buses without a terminal block or properly-wired cable connected, an error is generated. You can, however, *temporarily* disable errors generated by the Safety Interlock feature. This simulation mode may be useful during test system development when you may not have connected any terminal blocks or cables to your module.

This feature is available from the remote interface only

CAUTION

The Safety Interlock feature is implemented in hardware on the modules and cannot be circumvented. Regardless of whether the simulation mode is enabled or disabled, all Analog Bus connections are prohibited as long as no terminal block or properly-wired cable is connected to the module.

- The simulation mode applies to the entire mainframe and cannot be selectively used on individual modules.
- When the simulation mode is enabled, the Analog Bus relays will *appear* to close and open as directed. For example, no errors are generated if you close an Analog Bus relay from the front panel, remote interface, or Web Interface. However, remember that the Safety Interlock feature prevents the actual hardware state of the Analog Bus relays from being changed. When you connect a terminal block or cable to the module, the Analog Bus relays will be closed.
- The simulation setting is stored in volatile memory and will be lost when power is turned off. To re-enable the simulation mode after power has been off, you must send the command again.

Remote Interface Operation: `SYSTEM:ABUS:INTerlock:SIMulate {OFF|ON}`

User-Defined Channel Labels

You can assign user-defined labels to any channel, including Analog Bus channels on the multiplexer and matrix modules. User-defined channel labels are available for identification purposes *only* and cannot be used in place of a channel number within a command string.

- When shipped from the factory, each channel is assigned a unique factory-default label (cannot be overwritten). From the front panel, the factory-default labels are shown on the upper line of the display (e.g., “MUX CH BANK 1”, “MATRIX1 ROW3 COL4”, “DIO BYTE 1”, etc.). From the Web Interface, the factory-default labels are displayed as the channel number (e.g., “1001”, “3020”, etc.).
- If desired, you can assign the same user-defined label to multiple channels within the same module or on different modules (i.e., channel labels are not required to be unique).
- You can specify a label with up to 18 characters. You can use letters (A-Z), numbers (0-9), and the underscore character. If you specify a label with more than the allowed 18 characters, it will be truncated (no error is generated).
- From the Web Interface, a limited number of characters can be displayed due to space constraints in the browser window. If the user-defined label is too long to be displayed properly, it will be truncated (no error is generated).
- The instrument keeps a record of what module types are installed in each slot. If a different module type is detected in a specific slot at power on, all user-defined channel labels for that slot are discarded. If an empty slot is detected at power-on, any previously-defined labels for that slot are preserved and will be restored if the same module type is installed later; however, if a module of a different type is installed in that slot, the previously-defined labels will be discarded.
- All user-defined channel labels are stored in non-volatile memory, and do not change when power has been off, after a Factory Reset (*RST command), after an Instrument Preset (SYSTEM:PRESet command), or after a stored state is recalled (*RCL command).

Front Panel Operation: Channel (Configure) > CHANNEL LABEL

To define the channel label, press the arrow keys to move the cursor to a specific position and then turn the knob to select the desired letter or number.

To clear the channel label on the selected channel, change each character to “^” (starting with the rightmost character) and then press the left arrow key to move to the next character.

To clear all channel labels on the selected module, navigate to:

```
Module (Configure) > CLEAR LABELS? > YES
```

Remote Interface Operation: The following command assigns a label (“TEST_PT_1”) to channel 3 in slot 1.

```
ROUT:CHAN:LABEL "TEST_PT_1", (@1003)
```

The following command clears the user-defined label previously assigned to channel 3 in slot 1. The channel will now be identified by its factory default label (e.g., “MUX CH BANK 1”, “MATRIX1 ROW3 COL4”, “DIO BYTE 1”, etc.).

```
ROUT:CHAN:LABEL "", (@1003)
```

The following command clears all user-defined channel labels on the module in slot 1. The factory-default labels are assigned to all channels on the module in slot 1.

```
ROUT:CHAN:LABEL: CLEAR: MOD 1
```

The following command clears all user-defined labels on all modules installed in the 34980A. The factory-default labels are assigned to all channels on all installed modules.

```
ROUT:CHAN:LABEL: CLEAR: MOD ALL
```

2-Wire Versus 1-Wire Mode

You can configure the 34923A, 34925A, and 34933A modules for 2-wire (differential) or 1-wire (single ended) measurements. If you change the module configuration, you must cycle power on the 34980A to activate the new setting.

- To determine whether the module is in the 2-wire or 1-wire configuration, check the module description shown on the front panel when the module is selected, or send the `SYSTEM:CTYPE?` or `SYSTEM:CDESCRIPTION?` command. For example, the `SYSTEM:CTYPE?` response for the 34923A will be either “34923A” (differential mode) or “34923A-1W” (single-ended mode).
- If you are using terminal blocks with these modules, be sure to use the corresponding 2-wire or 1-wire terminal block.
- The module configuration is stored in non-volatile memory on the module and does not change when you remove the module from the mainframe, after a Factory Reset (`*RST` command), or after an Instrument Preset (`SYSTEM:PRESET` command).

Front Panel Operation: Module (Configure) > MODE NEXT POWER-ON

After selecting the 2-wire (“WIRE2”) or 1-wire (“WIRE1”), you must cycle power on the 34980A to activate the new setting.

Remote Interface Operation: The following command selects the 1-wire configuration on the module in slot 3. The new configuration will not take effect until you cycle power on the 34980A.

```
SYST:MOD:WIRE:MODE WIRE1,3
```

Analog Bus and Internal DMM Considerations

This section provides important environmental and electrical considerations that can affect mainframe operation.

Environmental Operating Conditions

The 34980A mainframe, including the optional internal DMM, is designed to operate in a temperature range of 0 °C to +55 °C with non-condensing humidity. The maximum humidity is 80% at 40 °C or higher. Do not use in locations where conductive dust or electrolytic salt dust may be present.

The 34980A should be operated in an indoor environment where temperature and humidity are controlled. Condensation can pose a potential shock hazard. Condensation can occur when the instrument is moved from a cold to a warm environment, or if the temperature and/or humidity of the environment changes quickly.

When used in pollution degree 1 conditions, the maximum voltage rating for the Analog Buses is 300V. When used in pollution degree 2 conditions, the maximum voltage rating is 100V. If conditions change, ensure that condensation has evaporated and the instrument has thermally stabilized until pollution degree 1 conditions are restored before turning on power to the equipment.

NOTE

Pollution Degree 1: No pollution or only dry, non-conductive pollution occurs. The pollution has no influence (on insulation) (IEC 61010-1 2nd Edition).

NOTE

Pollution Degree 2: Normally only non-conductive pollution occurs. Occasionally, a temporary conductivity (leakage current between isolated conductors) caused by condensation can be expected (IEC 61010-1 2nd Edition).

Electrical Operating Conditions

WARNING

To avoid electric shock, turn off the 34980A and disconnect or de-energize all field wiring to the modules and the Analog Bus connector before removing any module or slot cover.

Transients

The Analog Buses and the optional internal DMM are designed to safely withstand occasional transient overvoltages up to 1000 V_{peak}. Typically, these transient overvoltages result from switching inductive loads or from nearby lightning strikes. The lightning-caused transient overvoltages that may occasionally occur on mains power outlets may be as high as 2500 V_{peak}.

WARNING

Do not connect the Analog Buses directly to a mains power outlet. If it is necessary to measure a mains voltage or any circuit where a large inductive load may be switched, you must add signal conditioning elements to reduce the potential transients before they reach the Analog Buses.

High Energy Sources

The Analog Buses and the optional internal DMM are designed to handle inputs up to their rated currents or their rated powers, whichever is less. Under certain fault conditions, high energy sources could provide substantially more current or power than the instrument can handle. It is important to provide external current limiting, such as fuses, if the inputs are connected to high-energy sources.

CAUTION

Install current limiting devices between high energy sources and the module inputs.

Temperature Measurement Configuration

This section contains information to help you configure the instrument for making temperature measurements. The table below shows the thermocouple, RTD, and thermistor types for which the instrument supports direct measurements.

Temperature transducers supported

Thermocouple Types *	RTD Types	Thermistor Types
B, E, J, K, N, R, S, T	$R_0 = 49\Omega$ to 2.1 k Ω $\alpha = 0.00385$ (DIN/IEC 751) * $\alpha = 0.00391$ †	2.2 k Ω , 5 k Ω , 10 k Ω (YSI 44000 Series)

* Using ITS-90 software conversions.

† Using IPTS-68 software conversions.

Measurement Units

- The instrument can report temperature measurements in °C (Celsius), °F (Fahrenheit), or K (Kelvins). You can mix temperature units on different channels within the instrument and on the same module.
- The CONFigure and MEASure? commands automatically select °C.
- Setting the Mx+B measurement label to °C, °F, or K has *no* affect on the temperature measurement units currently selected.
- The instrument selects Celsius when the probe type is changed and after a Factory Reset (*RST command). An Instrument Preset (SYSTEM:PRESet command) or Card Reset (SYSTEM:CPON command) does *not* change the units setting.

Front Panel Operation: DMM or Channel (Configure) > TEMPERATURE > UNITS

Remote Interface Operation: UNIT:TEMP {C|F|K} [, (@<ch_list>)]

Thermocouple Measurements

- The instrument supports the following thermocouple types: B, E, J, K, N, R, S, and T using ITS-90 software conversions. *The default is a J-Type thermocouple.*
- Thermocouple measurements require a reference junction temperature. For the reference junction temperature, you can use an internal measurement on the module (34921A only), an external thermistor or RTD measurement, or a known fixed junction temperature.
 - The *internal* reference junction source is valid only on channels 1 through 40 on the 34921A with the 34921T terminal block installed.
 - If you select an *external* reference, the instrument makes thermocouple measurements relative to a previously-stored RTD or thermistor measurement stored in a reference register. To store a reference temperature, first configure a multiplexer channel for an RTD or thermistor measurement. Then assign the measurement from that channel as the external reference. When you initiate a measurement on an external reference channel, the acquired temperature is stored in volatile memory in the reference register. Subsequent thermocouple measurements use the stored temperature as their reference. The temperature remains in memory until you measure a subsequent external reference value in the reference register or remove the mainframe power.
 - If you select a *fixed* reference temperature, specify a value between -20 °C and +80 °C (always specify the temperature in °C regardless of the temperature units currently selected).
- The accuracy of the measurement is highly dependent upon the thermocouple connections and the type of reference junction used. Use a fixed temperature reference for the highest accuracy measurements (you must maintain the known junction temperature). The internal isothermal block reference (34921A only) requires no external wiring but provides lower accuracy measurements than a fixed reference.
- The *thermocouple check* feature allows you to verify that your thermocouples are properly connected for measurements. If you enable this feature, the instrument measures the channel resistance after each thermocouple measurement to ensure a proper connection. If an open connection is detected (greater than 5 k Ω on the 10 k Ω range), the instrument reports an overload condition for that channel (or displays “OPEN T/C” on the front panel).

Front Panel Operation: To select the thermocouple function on the active channel, choose the following items.

```
DMM or Channel (Configure) > TEMPERATURE > PROBE TYPE > THERMOCOUPLE
```

Then, use the knob to select the thermocouple type from the list.

```
THERMOCOUPLE TYPE > B|E|J|K|N|R|S|T
```

If desired, you can enable the thermocouple check feature on the active channel (opens are reported as “OPEN T/C”).

```
T/C CHECK > OFF|ON
```

To select the reference junction source for the active channel, choose one of the following items.

```
REFERENCE > FIXED|EXT|INT
```

For an external reference, configure an RTD or thermistor as the external reference channel.

```
Channel (Configure) > TEMPERATURE > PROBE TYPE > RTD > ... USE AS EXT REF?
```

Remote Interface Operation: You can use the `CONFigure` or `MEASure?` command to select the probe type and thermocouple type. For example, the following command configures channel 3001 for a J-type thermocouple measurement.

```
CONF:TEMP TC,J, (@3001)
```

You can also use the `SENSe` command to select the probe type and thermocouple type. For example, the following command configures channel 2003 for a J-type thermocouple measurement.

```
SENS:TEMP:TRAN:TC:TYPE J, (@2003)
```

The following commands use the `SENSe` command to set a fixed reference junction temperature of 40 degrees (always in °C) on channel 2003.

```
SENS:TEMP:TRAN:TC:RJUN:TYPE, (@2003)  
SENS:TEMP:TRAN:TC:RJUN 40, (@2003)
```

The following command enables the thermocouple check feature on the specified channel (opens are reported as “+9.90000000E+37”).

```
SENS:TEMP:TRAN:TC:CHECK ON, (@2003)
```

The following commands select the fixed reference junction source and set the junction temperature to 20 °C on the specified channel.

```
TEMP:TRAN:TC:RJUN:TYPE FIX, (@2003)  
TEMP:TRAN:TC:RJUN 20, (@2003)
```

RTD Measurements

- The instrument supports RTDs with $\alpha = 0.00385$ (DIN/IEC 751) using ITS-90 software conversions or $\alpha = 0.00391$ using IPTS-68 software conversions. The default is $\alpha = 0.00385$.
- The resistance of an RTD is nominal at 0 °C and is referred to as R_0 . The instrument can measure RTDs with R_0 values from 49 Ω to 2.1 k Ω .
- You can measure RTDs using a 2-wire or 4-wire measurement method. The 4-wire method provides the most accurate way to measure small resistances. Connection lead resistance is automatically removed using the 4-wire method.
- For 4-wire RTD measurements, the instrument automatically pairs channel n in Bank 1 with channel $n+20$ in Bank 2 (34921A, 34923A) or $n+35$ (34922A, 34924A) to provide the source and sense connections. For example, make the source connections to the HI and LO terminals on channel 2 in Bank 1 and the sense connections to the HI and LO terminals on channel 22 (or 37) in Bank 2.

Front Panel Operation: To select the 2-wire or 4-wire RTD function for the active channel, choose the following items.

DMM or Channel (Configure) > TEMPERATURE > PROBE TYPE > RTD|4W RTD

To select the RTD type ($\alpha = 0.00385$ or 0.00391) for the active channel, choose the following item.

RTD TYPE > 0.00391|0.00385

To select the nominal resistance (R_0) for the active channel, choose the following item.

RO > 100 OHM

Remote Interface Operation: You can use the CONFigure or MEASure? command to select the probe type and RTD type. For example, the following command configures channel 3001 for 2-wire measurements of an RTD with $\alpha = 0.00385$ (use “85” to specify $\alpha = 0.00385$ or “91” to specify $\alpha = 0.00391$).

```
CONF:TEMP RTD,85,(@3001)
```

You can also use the SENSE command to select the probe type, RTD type, and nominal resistance. For example, the following command configures channel 1003 for 4-wire measurements of an RTD with $\alpha = 0.00391$ (channel 1003 is automatically paired with channel 1023 for the 4-wire measurement).

```
SENS:TEMP:TRAN:FRTD:TYPE 91,(@1003)
```

The following command sets the nominal resistance (R_0) to 1000 Ω on channel 1003.

```
SENS:TEMP:TRAN:FRTD:RES 1000, (@1003)
```

Thermistor Measurements

The instrument supports 2.2 k Ω (YSI Series 44004), 5 k Ω (YSI Series 44007), and 10 k Ω (YSI Series 44006) thermistors.

Front Panel Operation: To select the thermistor function for the active channel, choose the following items.

```
DMM or Channel (Configure) > TEMPERATURE > PROBE TYPE > THERMISTOR
```

To select the thermistor type for the active channel, choose from the following items.

```
THERMISTOR TYPE > 10K|5K|2.2K
```

Remote Interface Operation: You can use the `CONFigure` or `MEASure?` command to select the probe type and thermistor type. For example, the following command configures channel 3001 for measurements of a 5 k Ω thermistor:

```
CONF:TEMP THER,5000, (@3001)
```

You can also use the `SENSe` command to select the probe type and thermistor type. For example, the following command configures channel 1003 for measurements of a 10 k Ω thermistor:

```
SENS:TEMP:TRAN:THERM:TYPE 10000, (@1003)
```

Voltage Measurement Configuration

This section contains information to help you configure the instrument for making voltage measurements. The instrument can measure dc and true RMS ac-coupled voltages on the measurement ranges shown below.

100 mV	1 V	10 V	100 V	300 V	Autorange
--------	-----	------	-------	-------	-----------

DC Input Resistance

Normally, the instrument's input resistance is fixed at 10 M Ω for all dc voltage ranges to minimize noise pickup. To reduce the effects of measurement loading errors, you can set the input resistance to greater than 10 G Ω for the 100 mVdc, 1 Vdc, and 10 Vdc ranges.

Applies to dc voltage measurements only.

DC input resistance

Input Resistance Setting	Input Resistance for: 100 mV, 1 V, 10 V ranges	Input Resistance for: 100 V, 300 V ranges
Input Resistance: Auto OFF	10 M Ω	10 M Ω
Input Resistance: Auto ON	> 10 G Ω	10 M Ω

- The `CONFigure` and `MEASure?` commands automatically select AUTO OFF (fixed at 10 M Ω for all ranges).
- The instrument selects 10 M Ω (fixed input resistance on all dc voltage ranges) after a Factory Reset (`*RST` command). An Instrument Preset (`SYSTEM:PRESet` command) or Card Reset (`SYSTEM:CPON` command) does *not* change the input resistance setting.

Front Panel Operation: DMM or Channel (Configure) > INPUT RESISTANCE

Remote Interface Operation: You can enable or disable the automatic input resistance mode on the specified channels or the internal DMM. With AUTO OFF (default), the input resistance is fixed at 10 M Ω for all ranges. With AUTO ON, the input resistance is set to >10 G Ω for the three lowest dc voltage ranges.

```
[SENSe:]<function>:IMPedance:AUTO {OFF|ON} [, (@<ch_list>)]
```

If you omit the optional `<ch_list>` parameter, the command applies to the internal DMM.

AC Low Frequency Filter

The instrument uses three different ac filters which enable you to either optimize low-frequency accuracy or achieve faster ac settling times. The instrument selects the *slow* (3 Hz), *medium* (20 Hz), or *fast* (300 Hz) filter based on the input frequency that you specify for the selected channels or the internal DMM.

Applies to ac voltage and ac current measurements only.

AC low frequency filter

Input Frequency	Default Settling Delay	Minimum Settling Delay
3 Hz to 300 kHz (Slow)	7 seconds / reading	1.5 seconds
20 Hz to 300 kHz (Medium)	1 second / reading	200 ms
200 Hz to 300 kHz (Fast)	0.12 seconds / reading	20 ms

- The `CONFigure` and `MEASure?` commands automatically select the 20 Hz (medium) filter.
- The instrument selects the default 20 Hz (medium) filter after a Factory Reset (`*RST` command). An Instrument Preset (`SYSTem:PRESet` command) or Card Reset (`SYSTem:CPON` command) does *not* change the setting.

Front Panel Operation: DMM or Channel (Configure) > AC FILTER

Remote Interface Operation: Specify the lowest frequency expected in the input signal on the specified channels. The instrument selects the appropriate filter based on the frequency you specify (see table above).

```
[SENSe:]VOLTage:AC:BANDwidth {3|20|200} [, (@<ch_list>)]
```

If you omit the optional `<ch_list>` parameter, the command applies to the internal DMM.

Resistance Measurement Configuration

This section contains information to help you configure the instrument for making resistance measurements. Use the 2-wire method for ease of wiring and higher density or use the 4-wire method for improved measurement accuracy. The measurement ranges shown below.

100Ω	1 kΩ	10 kΩ	100 kΩ	1 MΩ	10 MΩ	100 MΩ	Autorange
------	------	-------	--------	------	-------	--------	-----------

Offset Compensation

Offset compensation removes the effects of any dc voltages in the circuit being measured. The technique involves taking the difference between two resistance measurements on the specified channels, one with the current source turned on and one with the current source turned off.

Applies only to 2-wire and 4-wire resistance measurements on the 100Ω, 1 kΩ, and 10 kΩ ranges.

- Four-wire measurements are not allowed on the multiplexer modules configured for the 1-wire (single ended) mode (see [page 27](#)).
- For 4-wire resistance measurements, the instrument automatically pairs channel n in Bank 1 with channel $n+20$ in Bank 2 (34921A, 34923A, 34925A) or $n+35$ (34922A, 34924A) to provide the source and sense connections. For example, make the source connections to the HI and LO terminals on channel 2 in Bank 1 and the sense connections to the HI and LO terminals on channel 22 (or 37) in Bank 2.
- The CONFigure and MEASure? commands automatically disable offset compensation.
- The instrument disables offset compensation after a Factory Reset (*RST command). An Instrument Preset (SYSTEM:PRESet command) or Card Reset (SYSTEM:CPON command) does *not* change the setting.

Front Panel Operation: DMM or Channel (Configure) > OFFSET COMP

Remote Interface Operation:

```
[SENSe:]FRESistance:OCOMPensated {OFF|ON} [, (@<ch_list>)]
[SENSe:]RESistance:OCOMPensated {OFF|ON} [, (@<ch_list>)]
```

If you omit the optional <ch_list> parameter, the command applies to the internal DMM. For 4-wire measurements, specify the paired channel in Bank 1 (source) as the <ch_list> channel (channels in Bank 2 are not allowed in the <ch_list>).

Current Measurement Configuration

This section contains information to help you configure the instrument for making current measurements on the 34921A multiplexer module. The module has four fused channels for direct dc and ac current measurements on the ranges shown below.

10 mA	100 mA	1 A	Autorange
-------	--------	-----	-----------

Current measurements are allowed only on channels 41 through 44 on the 34921A module.

AC Low Frequency Filter

The instrument uses three different ac filters which enable you to either optimize low-frequency accuracy or achieve faster ac settling times. The instrument selects the *slow* (3 Hz), *medium* (20 Hz), or *fast* (300 Hz) filter based on the input frequency that you specify for the selected channels or the internal DMM.

Applies to ac current and ac voltage measurements only.

AC low frequency filter

Input Frequency	Default Settling Delay	Minimum Settling Delay
3 Hz to 300 kHz (Slow)	7 seconds / reading	1.5 seconds
20 Hz to 300 kHz (Medium)	1 second / reading	200 ms
200 Hz to 300 kHz (Fast)	0.12 seconds / reading	20 ms

- The `CONFigure` and `MEASure?` commands automatically select the 20 Hz (medium) filter.
- The instrument selects the default 20 Hz (medium) filter after a Factory Reset (`*RST` command). An Instrument Preset (`SYSTem:PRESet` command) or Card Reset (`SYSTem:CPON` command) does *not* change the setting.

Front Panel Operation: DMM or Channel (Configure) > AC FILTER

Remote Interface Operation: Specify the lowest frequency expected in the input signal on the specified channels. The instrument selects the appropriate filter based on the frequency you specify (see table above).

```
[SENSE:]CURRENT:AC:BANDwidth {3|20|200} [, (@<ch_list>)]
```

If you omit the optional `<ch_list>` parameter, the command applies to the internal DMM.

Frequency Measurement Configuration

This section contains information to help you configure the instrument for making frequency measurements.

Low Frequency Timeout

The instrument uses three different timeout ranges for frequency measurements. The instrument selects the *slow* (3 Hz), *medium* (20 Hz), or *fast* (300 Hz) filter based on the input frequency that you specify with this command for the selected channels.

Applies to frequency measurements only.

Low frequency timeout

Input Frequency	Timeout
3 Hz to 300 kHz (Slow)	1 second
20 Hz to 300 kHz (Medium)	100 ms
200 Hz to 300 kHz (Fast)	10 ms

- The `CONFigure` and `MEASure?` commands automatically select the 20 Hz (medium) filter.
- The instrument selects the default 20 Hz (medium) filter after a Factory Reset (`*RST` command). An Instrument Preset (`SYSTem:PRESet` command) or Card Reset (`SYSTem:CPON` command) does *not* change the setting.

Front Panel Operation: DMM or Channel (Configure) > AC FILTER

Remote Interface Operation: Specify the lowest frequency expected in the input signal on the specified channels. The instrument selects the appropriate timeout based on the frequency you specify (see table above).

```
[SENSe:]FREQuency:RANGe:LOWer {3|20|200} [, (@<ch_list>)]
```

If you omit the optional `<ch_list>` parameter, the command applies to the internal DMM.

Mx+B Scaling

The scaling function allows you to apply a *gain* and *offset* to readings during a scan or while making measurements in the stand-alone DMM mode. In addition to setting the gain (“M”) and offset (“B”) values, you can also specify a custom measurement label for your scaled readings (RPM, PSI, etc.). You can apply scaling to any multiplexer channels and for any measurement function. Scaling is not allowed with any of the channels on the digital modules.

- Scaling is applied using the following equation:

$$\text{Scaled Reading} = (\text{Gain} \times \text{Measurement}) + \text{Offset}$$

- You must configure the channel (function, transducer type, etc.) before applying any scaling values. If you change the measurement configuration, scaling is turned off on that channel and the gain and offset values are reset (M=1 and B=0). Scaling is also turned off when you change the temperature probe type, temperature units, or disable the internal DMM.
- If you plan to use scaling on a channel which will also use alarms, *be sure to configure the scaling values first*. If you attempt to assign the alarm limits first, the instrument will turn off alarms and clear the limit values when you enable scaling on that channel. If you specify a custom measurement label with scaling, it is automatically used when alarms are logged on that channel.
- If you redefine the scan list, scaling is turned off on those channels but the gain and offset values are not cleared. If you decide to add a channel back to the scan list (without changing the function), the original gain and offset values are restored and scaling is turned back on. This makes it easy to temporarily remove a channel from the scan list without entering the scaling values again.
- You can specify a custom label with up to three characters. You can use letters (A-Z), numbers (0-9), an underscore (_), or the “#” character which displays a degree symbol (°) on the front panel (displayed as a “#” in an output string from the remote interface). The first character must be a letter or the “#” character (the “#” character is allowed only as the leftmost character in the label). The remaining two characters can be letters, numbers, or an underscore. Blank spaces are not allowed.
- The maximum value allowed for the gain and offset is $\pm 1\text{E}+15$.

- The `CONFigure` and `MEASure?` commands automatically set the gain (“M”) to 1 and offset (“B”) to 0.
- A Factory Reset (`*RST` command) turns off scaling and clears the scaling values on all channels. An Instrument Preset (`SYSTem:PRESet` command) does *not* clear the scaling values and does *not* turn off scaling.

Front Panel Operation:

DMM or Channel (Configure) > SCALING > GAIN|OFFSET|UNITS

To define the label on the selected channel, press the arrow keys to move the cursor to a specific position and then turn the knob to select the desired letter or number. To clear the label on the selected channel, change each character to “^” (starting with the rightmost character) and then press the left arrow key to move to the next character.

Remote Interface Operation: Use the following commands to set the gain, offset, and custom measurement label.

```
CALC:SCALE:GAIN 1.2, (@1003)
CALC:SCALE:OFFSET 10, (@1003)
CALC:SCALE:UNIT 'PSI', (@1003)
```

After setting the gain and offset values, send the following command to enable the scaling function on the specified channel.

```
CALC:SCALE:STATE ON, (@1003)
```

Scanning

The instrument allows you to combine a DMM (either internal or external) with multiplexer channels to create a *scan*. During a scan, the instrument connects the DMM to the configured multiplexer channels one at a time and makes a measurement on each channel.

Any channel that can be “read” by the instrument can also be included in a scan. This includes any combination of temperature, voltage, resistance, current, frequency, or period measurements on multiplexer channels. A scan can also include a read of a digital channel or a read of the totalizer count on the digital modules. Scanning is allowed with the following modules:

- 34921A through 34925A Multiplexer Modules
- 34950A Digital I/O Module (digital input and counter channels only)
- 34952A Multifunction Module (digital input and totalizer channels only)

Automated scanning is not allowed with the other switching modules. In addition, a scan cannot include a write to a digital channel or a voltage output from a DAC channel. You can, however, write your own program to manually create a “scan” to include these operations.

Rules for Scanning

- Before you can initiate a scan, you must set up a scan list to include all desired multiplexer or digital channels. Channels which are not in the scan list are skipped during the scan. By default, the instrument scans the list of channels in ascending order from slot 1 through slot 8 (channels are reordered as needed). If your application requires non-ordered scanning of the channels in the present scan list, see [“Non-Sequential Scanning”](#) on page 57. Measurements are taken only during a scan and only on those channels which are included in the scan list.
- You can store at least 500,000 readings in memory and all readings are automatically time stamped. If memory overflows, a status register bit is set and new readings will overwrite the first (oldest) readings stored. The most recent readings are always preserved. You can read the contents of memory at any time, even during a scan. Reading memory is not cleared when you read it.
- Each time you start a new scan, the instrument clears all readings (including alarm data) stored in reading memory from the previous scan. Therefore, the contents of memory are always from the most recent scan.

- The Analog Bus relays are automatically opened and closed as required during the scan to connect to the internal DMM for the measurement. For example, all 2-wire measurements use the ABus1 (MEAS) relays; for 4-wire measurements, the ABus2 (SENS) relays are used in addition to the ABus1 relays.
- When the scan is initiated, the instrument will open all channels in banks that contain one or more channels in the scan list.
- In order to guarantee that no signals are connected to the Analog Buses prior to the scan, the instrument will open all ABus1 relays (applies to all banks in all slots). In banks that contain channels in the scan list, the instrument will also open all ABus2 relays (regardless of whether 4-wire measurements are involved). If no channels configured for 4-wire measurements are included in the scan list, the state of the ABus2 relays in the non-scanned banks is not altered.
- The state of the ABus3 and ABus4 relays is not altered and these relays remain available for use during the scan. However, be sure to use *CAUTION* when closing these relays on banks involved in the scan. While the scan is running, any signals present on ABus3 and/or ABus4 will be joined with the scanned measurement on ABus1 and ABus2.
- While the scan is running, the instrument prevents use of all channels in banks that contain one or more channels in the specified scan list (these channels are dedicated to the scan). In addition, the instrument prevents use of all ABus1 and ABus2 relays on banks containing channels in the scan list. If one or more channels configured for 4-wire measurements are included in the scan list, then the rules for ABus2 relay operations are extended to the non-scanned banks as well.
- If the ABus1 relay used for current measurements (channel 931 on 34921A only) is not closed prior to the initiation of the scan, the four current channels (channels 41 through 44) are not affected by the scan. However, if the ABus1 relay is closed, the instrument will open the ABus1 relay as well as the four associated current channels in a *make-before-break* fashion.
- When you add a digital read (digital modules) to a scan list, the corresponding channel is dedicated to the scan. The instrument issues a Card Reset to make that channel an input channel (the other channel is not affected).
- While the scan is running, you can perform low-level control operations on any channels on the digital modules that are not in the scan. For example, you can output a DAC voltage or write to a digital channel (even if the totalizer is part of the scan list). However, you cannot change any parameters that affect the scan (channel configuration, scan interval, Card Reset, etc.) while a scan is running.
- If a scan includes a read of the totalizer, the count is reset each time it is read during the scan *only* when the totalizer reset mode is enabled.

- At the end of the scan, the last channel that was scanned will be opened (as well as any Analog Bus relays used during the scan). Any channels that were opened during the scan will remain open at the completion of the scan.
- If you abort a scan that is running, the instrument will terminate any reading in progress (readings are not cleared from memory). If a scan is in progress when the command is received, the scan will not be completed and you cannot resume the scan from where it left off. Note that if you initiate a new scan, all readings are cleared from memory.
- You can use either the internal DMM or an external instrument to make measurements of your configured channels. However, the 34980A allows only one scan list at a time; you cannot scan some channels using the internal DMM and others using an external instrument. Readings are stored in 34980A memory only when the internal DMM is used.
- The Monitor mode is automatically enabled on all channels that are part of the active scan list (see “[Monitor Mode](#)” on page 60).
- The present scan list is stored in volatile memory and will be lost when power is turned off or after a Factory Reset (*RST command).

Adding Channels to the Scan List

Before you can initiate a scan, you must set up a scan list to include all desired multiplexer or digital channels. Channels which are not in the scan list are skipped during the scan. By default, the instrument scans the list of channels in ascending order from slot 1 through slot 8 (channels are reordered as needed).

To Build a Scan List From the Front Panel

- To add the active channel to the scan list, press Channel (Configure). Then select the function, range, resolution, and other parameters for this channel. Then add the channel to the scan list by selecting:

SCAN THIS CHANNEL? > YES

- To remove the active channel from the scan list, select:

SCAN THIS CHANNEL? > NO

- To remove all channels from the scan list, select:

Scan (Configure) > CLEAR SCAN LIST? > YES

- To initiate a scan and store all readings in memory, press Scan (Measure). Each time you initiate a new scan, the instrument clears all previously stored readings. If you have not defined a scan list, Scan (Measure) performs an internal DMM scan independent of any channels.
- To stop a scan in progress, press and hold Scan (Measure).

To Build a Scan List From the Remote Interface

- Use the `ROUTE:SCAN` command to define the list of channels in the scan list. To determine what channels are currently in the scan list, use the `ROUTE:SCAN?` query command.
- To add channels to the present scan list, use the `ROUTE:SCAN:ADD` command. To remove channels from the present scan list, use the `ROUTE:SCAN:REMOVe` command.
- To remove all channels from the scan list, send “`ROUT:SCAN (@)`”.
- To initiate a scan, use the `INITiate` or `READ?` command. Measurements are stored in memory. Each time you initiate a new scan, the instrument will clear the previous set of readings from memory.
- To stop a scan in progress, use the `ABORT` command.

Scan Trigger Source

You can configure the event or action that controls the onset of each sweep through the scan list (a *sweep* is one pass through the scan list):

- You can set the instrument's internal timer to automatically scan at a specific interval. You can also program a time delay between channels in the scan list (see “[Channel Delay](#)” on page 53).
- You can manually control a scan by repeatedly pressing the Scan (Measure) key from the front panel.
- You can start a scan by sending a software command from the remote interface (MEASure? or INITiate command).
- You can start a scan when an external TTL trigger pulse is received.

Interval Scanning

In this configuration, you control the frequency of scan sweeps by selecting a wait period from the start of one trigger to the start of the next trigger (called the *trigger-to-trigger interval*). If the scan interval is less than the time required to measure all channels in the scan list, the instrument will scan continuously, as fast as possible (no error is generated).

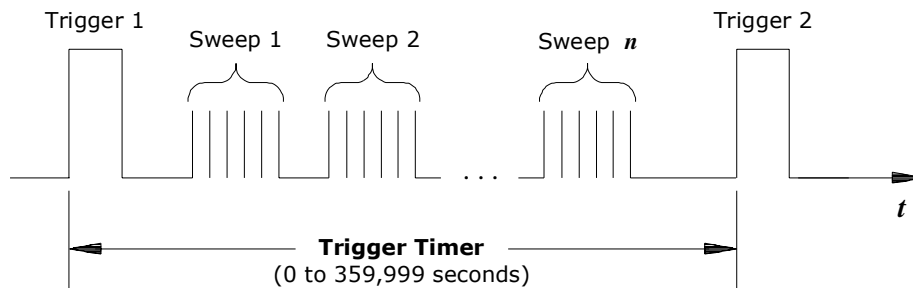

Trigger-to-trigger interval

- You can set the scan interval to any value between 0 seconds and 99:59:59 hours (359,999 seconds), with 1 ms resolution.
- Once you have initiated the scan, the instrument will continue scanning until you stop it or until the trigger count is reached. See “[Trigger Count](#)” on page 49 for more information.
- Mx+B scaling and alarm limits are applied to measurements during a scan and all data is stored in non-volatile memory.
- The CONFigure and MEASure? commands automatically set the scan interval to immediate (0 seconds) and the scan count to 1 sweep.

- The instrument sets the scan interval to immediate (0 seconds) after a Factory Reset (*RST command). An Instrument Preset (SYSTem:PRESet command) or Card Reset (SYSTem:CPON command) does *not* change the setting.

Front Panel Operation: Scan (Configure) > INTERVAL > SCAN INTERVAL

To initiate the scan and store all readings in memory, press the Scan (Measure) key. Between scan sweeps, “WAITING FOR TRIG” will be displayed on the front panel.

Note: To stop a scan, press and hold the Scan (Measure) key.

Remote Interface Operation: The following program segment configures the instrument for an interval scan.

TRIG:SOURCE TIMER	<i>Select interval time mode</i>
TRIG:TIMER 5	<i>Set the scan interval to 5 seconds</i>
TRIG:COUNT 2	<i>Sweep the scan list 2 times</i>
INIT	<i>Initiate the scan</i>

Note: To stop a scan, press and hold the Scan (Measure) key.

Manual Scanning

In this configuration, the instrument waits for either a front-panel key press or a remote interface command before sweeping through the scan list.

- All readings from the scan are stored in non-volatile memory. Readings accumulate in memory until the scan is terminated (until the trigger count is reached or until you abort the scan).
- You can specify a trigger count which sets the number of front-panel key presses or scan trigger commands that will be accepted before terminating the scan. See “[Trigger Count](#)” on page 49 for more information.
- Mx+B scaling and alarm limits are applied to measurements during a manual scanning operation and all data is stored in non-volatile memory.

Front Panel Operation: Scan (Configure) > INTERVAL > MANUAL

To initiate the scan and store all readings in memory, press the Scan (Measure) key.

Note: To stop a scan, press and hold the Scan (Measure) key.

Remote Interface Operation: The following program segment configures the instrument for a manual scanning operation.

```

TRIG:SOURCE BUS           Select bus (manual) mode
TRIG:COUNT 2            Sweep the scan list 2 times
INIT                      Initiate the scan
    
```

Then, send the *TRG (trigger) command to begin each scan sweep. The *TRG command will not be accepted unless the internal DMM is in the “wait-for-trigger” state.

Note: To stop a scan, press and hold the Scan (Measure) key.

External Scanning

In this configuration, the instrument sweeps through the scan list once each time a low-going TTL pulse is received on the rear-panel *Ext Trig Input* line (pin 6).

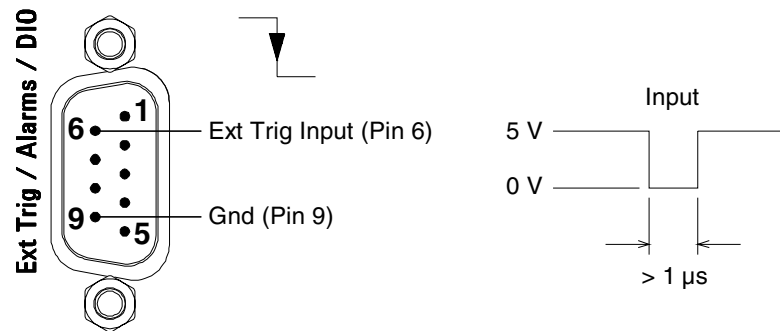

Ext Trig Input connector (as viewed from rear of instrument)

- You can specify a scan count which sets the number of external pulses the instrument will accept before terminating the scan. See “[Trigger Count](#)” on page 49 for more information.
- If the instrument receives an external trigger before it is ready to accept one, it will buffer one trigger and then ignore any additional triggers received (no error is generated).
- All readings from the scan are stored in non-volatile memory. Readings accumulate in memory until the scan is terminated (until the scan count is reached or until you abort the scan).
- Mx+B scaling and alarm limits are applied to measurements during the scan and all data is stored in non-volatile memory.

Front Panel Operation: Scan (Configure) > INTERVAL > EXTERNAL

To initiate the scan and store all readings in memory, press the Scan (Measure) key. Between scan sweeps, “WAITING FOR TRIG” will be displayed on the front panel. When a TTL pulse is received, the scan starts and readings are stored in memory.

Note: To stop a scan, press and hold the Scan (Measure) key.

Remote Interface Operation: The following program segment configures the instrument for an external scan.

TRIG:SOURCE EXT	<i>Select external mode</i>
TRIG:COUNT 2	<i>Sweep the scan list 2 times</i>
INIT	<i>Initiate the scan</i>

Note: To stop a scan, press and hold the Scan (Measure) key.

Trigger Count

You can specify the number of triggers that will be accepted by the internal DMM before returning to the “idle” state. The trigger count applies to both scanning and stand-alone DMM measurements (with no scan list).

- Select a trigger count between 1 and 500,000 triggers, or continuous.
- You can store at least 500,000 readings in memory and all readings are automatically time stamped. If memory overflows, the new readings will overwrite the first (oldest) readings stored; the most recent readings are always preserved.
- You can specify a trigger count in conjunction with a sample count and a sweep count. The three parameters operate independent of one another, and the total number of readings returned will be the product of the three parameters.
- The CONFigure and MEASure? commands automatically set the scan trigger count to 1.
- The instrument sets the scan trigger count to 1 after a Factory Reset (*RST command). An Instrument Preset (SYSTEM:PRESet command) or Card Reset (SYSTEM:CPON command) does *not* change the setting.

Front Panel Operation: Scan (Configure) > SCAN TRIGGER > COUNTED | INFINITE

Remote Interface Operation: TRIGger:COUNT

To configure a continuous scan, send TRIG:COUNT INFINITY.

Sweep Count

The sweep count sets the number of sweeps per trigger event during a scan (a *sweep* is one pass through the scan list). The front-panel sample annunciator (“*”) turns on during each measurement.

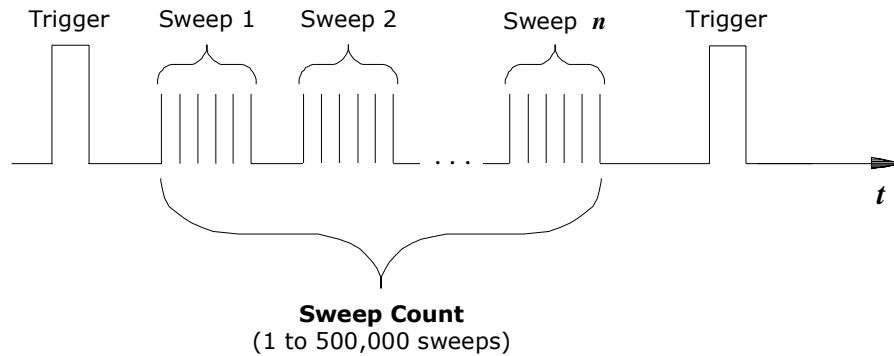

Sweep count

- The sweep count is valid only while scanning. If no channels have been assigned to the scan list, the specified sweep count is ignored (no error is generated).
- You can specify a sweep count in conjunction with a trigger count and a sample count. The three parameters operate independent of one another, and the total number of readings returned will be the product of the three parameters.
- You can store at least 500,000 readings in memory and all readings are automatically time stamped. If memory overflows, the new readings will overwrite the first (oldest) readings stored; the most recent readings are always preserved.
- The `CONFigure` and `MEASure?` commands automatically set the sweep count to 1 sweep.
- The instrument sets the sweep count to 1 after a Factory Reset (`*RST` command). An Instrument Preset (`SYSTEM:PRESet` command) or Card Reset (`SYSTEM:CPON` command) does *not* change the setting.

Front Panel Operation: Scan (Configure) > SWEEP COUNT

Remote Interface Operation: `SWEEp:COUNT`

Sample Count

The sample count sets the number of auto-triggered samples the internal DMM will take per channel per trigger. The sample count applies to both scanning and stand-alone DMM measurements (with no scan list). The front-panel sample annunciator (“*”) turns on during each measurement.

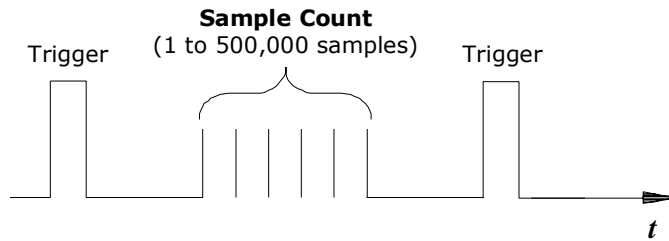

Sample count for Stand-Alone DMM Mode

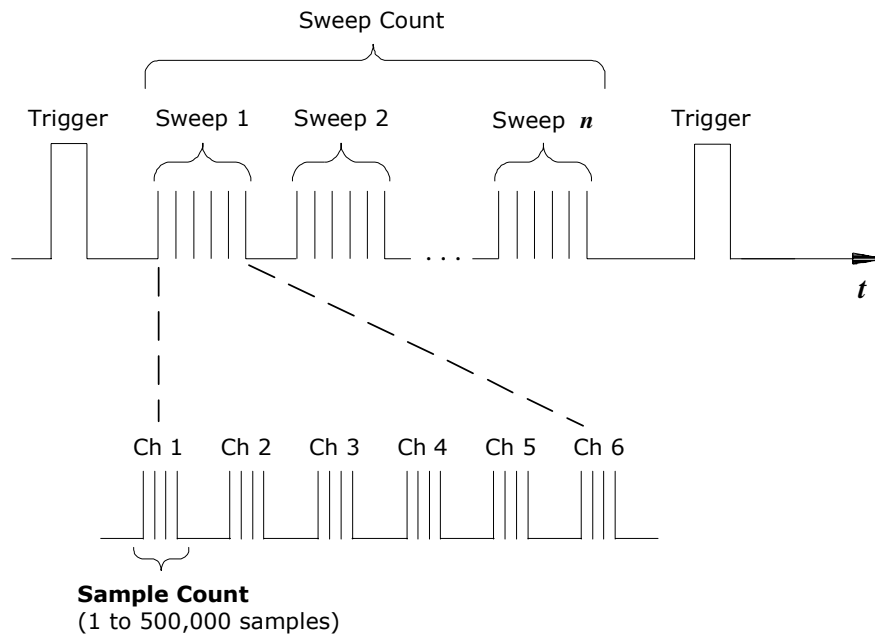

Sample count for Scanning Mode

- For scanning, the specified sample count sets the number of readings per channel (same for all channels in the scan list). If no channels have been assigned to the scan list, the sample count sets the number of readings per trigger for the internal DMM.
- You can specify a sample count in conjunction with a trigger count and a sweep count. The three parameters operate independent of one another, and the total number of readings returned will be the product of the three parameters.
- You can store at least 500,000 readings in memory and all readings are automatically time stamped. If memory overflows, the new readings will overwrite the first (oldest) readings stored; the most recent readings are always preserved.
- The `CONFigure` and `MEASure?` commands automatically set the sample count to 1.
- The instrument sets the sample count to 1 after a Factory Reset (`*RST` command). An Instrument Preset (`SYSTem:PRESet` command) or Card Reset (`SYSTem:CPON` command) does *not* change the setting.

Front Panel Operation: Scan (Configure) > SAMPLE COUNT

Remote Interface Operation: `SAMPlE:COUNT`

Channel Delay

You can control the pacing of a scan sweep by inserting a delay between multiplexer channels in the scan list (useful for high-impedance or high-capacitance circuits). The delay is inserted between the relay closure and the actual measurement on the channel, in addition to any delay that will implicitly occur due to relay settling time. The programmed channel delay overrides the default channel delay that the instrument automatically adds to each channel.

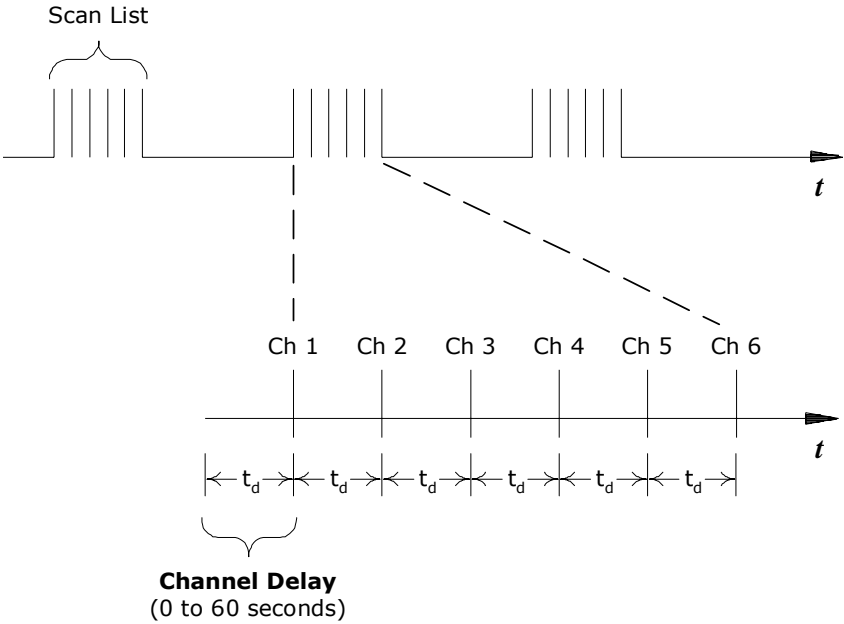

Channel delay

- You can set the channel delay to any value between 0 seconds and 60 seconds, with 1 ms resolution. You can select a different delay for each channel. The default channel delay is automatic; the instrument determines the delay based on function, range, integration time, and ac filter setting (see “Automatic Channel Delays” on page 54).
- You can select a unique delay for every channel on the module.
- The channel delay is valid only while scanning. If no channels have been assigned to the scan list, the specified channel delay is ignored (no error is generated).

- To ensure you are getting the most accurate measurements possible, use care when setting the channel delay less than the default value (automatic). The default channel delay is designed to optimize parameters, such as settling time, for the most accurate measurements.
- The `CONFigure` and `MEASure?` commands set the channel delay to automatic. A Factory Reset (`*RST` command) also sets the channel delay to automatic.

Front Panel Operation: Channel (Configure) > CHANNEL DELAY > TIME

Once you have added the specified channel to the scan list, the channel delay choice will be visible in the menu.

Interface Operation: The following command add a 2-second channel delay to the specified channels.

```
ROUT:CHAN:DELAY 2, (@1003,1013)
```

Automatic Channel Delays

If you do not specify a channel delay, the instrument selects a delay for you. The delay is determined by the delay based on function, range, integration time, and ac filter setting.

DC Voltage, Thermocouple, DC Current (for all ranges):

Integration Time	Channel Delay
PLC > 1	2.0 ms
PLC ≤ 1	1.0 ms

Resistance, RTD, Thermistor (2- and 4-wire):

Range	Channel Delay (for PLC > 1)	Range	Channel Delay (for PLC ≤ 1)
100Ω	2.0 ms	100Ω	1.0 ms
1 kΩ	2.0 ms	1 kΩ	1.0 ms
10 kΩ	2.0 ms	10 kΩ	1.0 ms
100 kΩ	25 ms	100 kΩ	20 ms
1 MΩ	30 ms	1 MΩ	25 ms
10 MΩ	200 ms	10 MΩ	200 ms
100 MΩ	200 ms	100 MΩ	200 ms

AC Voltage, AC Current (for all ranges):

AC Filter	Channel Delay
Slow (3 Hz)	7.0 seconds
Medium (20 Hz)	1.0 second
Fast (200 Hz)	120 ms

Frequency, Period:

AC Filter	Channel Delay
Slow (3 Hz)	600 ms
Medium (20 Hz)	300 ms
Fast (200 Hz)	100 ms

Digital Input, Totalize:

Channel Delay
0 seconds

Front Panel Operation: Channel (Configure) > CHANNEL DELAY > AUTO

Once you have added the specified channel to the scan list, the channel delay choice will be visible in the menu.

Interface Operation: The following command enables an automatic channel delay on the specified channels.

```
ROUT:CHAN:DELAY:AUTO ON, (@1003,1013)
```

Selecting a specific channel delay using the `ROUTe:CHANnel:DELay` command (see “Channel Delay” on page 53) disables the automatic channel delay.

Reading Format

During a scan, the instrument automatically adds a time stamp to all readings and stores them in memory. Each reading is stored with measurement units, time stamp, channel number, and alarm status information. From the remote interface, you can specify which information you want returned with the readings (from the front panel, all of the information is available for viewing). The examples below show a reading in *relative* and *absolute* format with all fields enabled.

Relative Format (Default):

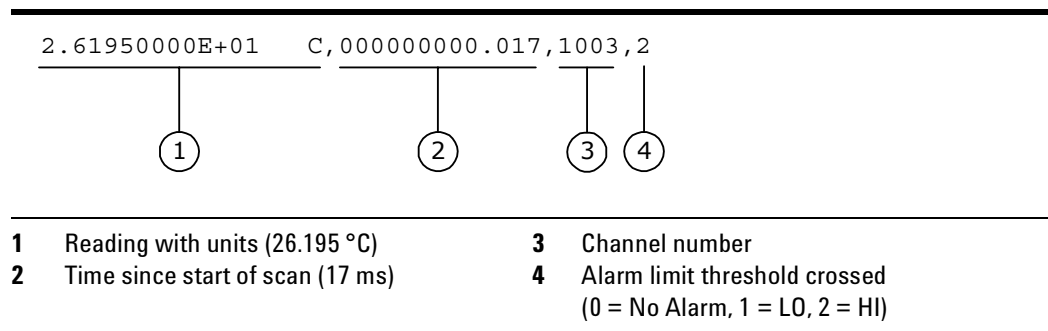

Absolute Format:

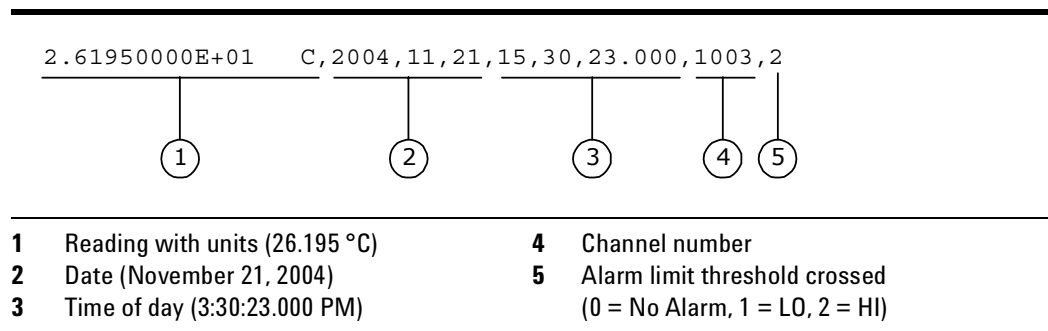

- The reading format applies to all readings being removed from the instrument from a scan; you cannot set the format on a per-channel basis.
- The CONFigure and MEASure? commands automatically turn off the units, time, channel, and alarm information.
- The format settings are stored in volatile memory and will be lost when power is turned off or after a Factory Reset (*RST command).

Remote Interface Operation: Use the following commands to select the reading format.

```
FORMat:READing:ALARm ON
FORMat:READing:CHANnel ON
FORMat:READing:TIME ON
FORMat:READing:TIME:TYPE {ABSolute|RELative}
FORMat:READing:UNIT ON
```

Non-Sequential Scanning

By default, the instrument scans the list of channels in ascending order from slot 1 through slot 8 (channels are reordered as needed). If your application requires non-ordered scanning of the channels in the present scan list, you can use the *non-sequential* scanning mode.

This feature is available from the remote interface only.

- The scanning mode applies to the entire mainframe and cannot be selectively used on individual modules.
- When sequential scanning is enabled (default), the channels in the scan list are placed in ascending order from slot 1 through slot 8. Duplicate channels are not allowed. For example, (@2001,1003,1001,1003) will be interpreted as (@1001,1003,2001).
- When sequential scanning is disabled (OFF), the channels remain in the order presented in the scan list (see exception below). Multiple occurrences of the same channel are allowed. For example, (@2001,2001,2001) and (@3010,1003,1001,1005) are valid and the channels will be scanned in the order presented.
- When you specify a range of channels in the scan list, the channels are always sorted in ascending order, regardless of the scan order setting. Therefore, (@1009:1001) will always be interpreted as 1001, 1002, 1003, etc.
- If you define a scan list with the sequential mode enabled and later disable the mode, the scan list will not be reordered; however, the scan list will be treated as a non-sequential list thereafter.
- If you have defined a scan list with the sequential mode disabled (OFF) and later enable the mode, the channels will be reordered.
- Non-sequential scan lists are not stored as part of the instrument state by the *SAV command; in this case, the ordered mode will be enabled and the scan list will be empty when the instrument state is restored (*RCL command).

- The scan order setting is stored in volatile memory and the ordered mode will be enabled when power is turned off or after a Factory Reset (*RST command).

Remote Interface Operation: ROUTe:SCAN:ORDERed {OFF|ON}

Viewing Readings Stored in Memory

- During a scan, the instrument automatically adds a time stamp to all readings and stores them in memory. You can read the contents of memory at any time, even during a scan. Reading memory is not cleared when you read it.
- You can store at least 500,000 readings in memory and all readings are automatically time stamped. If memory overflows, a status register bit is set and new readings will overwrite the first (oldest) readings stored. The most recent readings are always preserved.
- Each time you start a new scan, the instrument clears all readings (including alarm data) stored in reading memory from the previous scan. Therefore, the contents of memory are always from the most recent scan.
- The instrument clears all readings from memory after a Factory Reset (*RST command), after an Instrument Preset (SYSTem:PRESet command), or when mainframe power is cycled.
- The instrument clears all readings from memory when a new scan is initiated, when any measurement parameters are changed (CONFIgure and SENSE commands), and when the triggering configuration is changed (TRIGger commands).
- While a scan is running, the instrument automatically stores the minimum and maximum readings and calculates the average for each channel. You can read these values at any time, even during a scan.
- Each reading is stored with measurement units, time stamp, channel number, and alarm status information. From the remote interface, you can specify which information you want returned with the readings (from the front panel, all of the information is available for viewing). See “[Reading Format](#)” on page 56 for more information.
- Readings acquired during a Monitor are *not* stored in memory (however, all readings from a scan in progress at the same time are stored in memory).
- The INITiate command stores readings in memory. Use the FETCH? command to retrieve stored readings from memory (the readings are not erased when you read them).

Front Panel Operation: View > READINGS

Remote Interface Operation: The following command retrieves stored readings from memory (the readings are not erased).

```
FETCh?
```

Use the following commands to query the statistics on the readings stored in memory for a specific channel or from the internal DMM. These commands do *not* remove the data from memory.

CALC:AVER:MIN? (@3005)	<i>Minimum reading on channel</i>
CALC:AVER:MIN:TIME? (@3005)	<i>Time minimum was logged</i>
CALC:AVER:MAX? (@3005)	<i>Maximum reading on channel</i>
CALC:AVER:MAX:TIME? (@3005)	<i>Time maximum was logged</i>
CALC:AVER:AVER? (@3005)	<i>Average of all readings on channel</i>
CALC:AVER:COUNT? (@3005)	<i>Number of readings taken on channel</i>
CALC:AVER:PTPEAK? (@3005)	<i>Peak-to-peak (maximum–minimum)</i>

The following command retrieves the last reading taken on channel 1 on the module in slot 3 during a scan.

```
DATA:LAST? (@3001)
```

The following command clears the contents of statistics memory for the selected channel.

```
CALC:AVER:CLEAR (@3001)
```

Use the following command to determine the total number of readings stored in memory (all channels) from the most recent scan.

```
DATA:POINTS?
```

The following command reads and clears the specified number of readings from memory. This allows you to continue a scan without losing data stored in memory (if memory becomes full, new readings will overwrite the first readings stored). The specified number of readings are cleared from memory, starting with the oldest reading.

```
DATA:REMOVE? 12
```

Monitor Mode

In the Monitor mode, the instrument takes readings as often as it can on a single channel or the internal DMM, even during a scan. This feature is useful for troubleshooting your system before a test or for watching an important signal.

- Any channel that can be “read” by the instrument can be monitored. This includes any combination of temperature, voltage, resistance, current, frequency, or period measurements on multiplexer channels. You can also monitor a digital input channel or the totalizer count on the digital modules. You can also monitor measurements on the internal DMM, independent of any channel measurements.
- Readings acquired during a Monitor are *not* stored in memory but they are displayed on the front panel; however, all readings from a scan in progress at the same time are stored in memory.
- The Monitor mode is equivalent to making continuous measurements on a single channel or the internal DMM with an infinite scan count. Only one channel can be monitored at a time but you can change the channel being monitored at any time.
- A scan in progress always has priority over the Monitor function.
- Channels do *not* have to be part of an active scan list to be monitored; however, the channel must be configured for a measurement in order to be monitored.
- The Monitor mode ignores all trigger settings and takes continuous readings on the selected channel using the IMMEDIATE (continuous) source.
- The Monitor mode is automatically enabled on all channels that are part of the active scan list. If you define the scan list after monitoring has already been enabled, any channels that are not part of the active scan list will be ignored during the monitor operation (no error is generated).
- Mx+B scaling and alarm limits are applied to the selected channel during a Monitor and all alarm data is stored in the alarm queue (which will be cleared if power fails).
- You can monitor a digital input channel or totalizer channel even if the channel is not part of the scan list (the internal DMM is not required either). The count on a totalizer channel is not reset when it is being monitored (the Monitor ignores the totalizer reset mode).
- If a channel that is currently being monitored is manually closed or opened, the Monitor operation will be disabled on that channel.

Front Panel Operation: DMM or Channel (Measure)

For channel monitoring, turn the knob to the desired channel. To stop a Monitor, press the lighted key again.

Remote Interface Operation: Use the following command to select between the channel Monitor mode (default) and the internal DMM monitor mode.

```
ROUTE:MONitor:MODE {CHANnel|DMM}
```

The following program segment selects the channel to be monitored (specify only one channel) and enables the Monitor function.

```
ROUTE:MON:CHAN (@1003)
ROUTE:MON:CHAN:ENABLE ON, (@1003)
ROUTE:MON:STATE ON
```

The following program segment enables the Monitor function on the internal DMM:

```
ROUTE:MON:MODE DMM
ROUTE:MON:STATE ON
```

To read the monitor data from the selected channel or the internal DMM, send the following command. Each reading is returned with measurement units, time stamp, channel number, and alarm status information (see “[Reading Format](#)” on page 56).

```
ROUTE:MONitor:DATA?
```

System-Related Operations

This section gives information on system-related topics such as instrument state storage, error conditions, self-test, and front-panel display control. This information is not directly related to making measurements but is an important part of operating the instrument.

Firmware Revision

The mainframe, the internal DMM, and each of the plug-in modules has its own microprocessor. You can query each to determine which version of firmware is installed. For the mainframe, three firmware revision numbers are returned: mainframe revision, boot code revision, and front-panel revision. For the internal DMM and all plug-in modules, one firmware revision number is returned.

Front Panel Operation: Utility > FIRMWARE > REVISIONS

Use the knob to scroll through the revision numbers for the mainframe, internal DMM, and each installed module.

Remote Interface Operation: Use the following command to read the mainframe firmware revision numbers (be sure to dimension a string variable with at least 72 characters).

```
*IDN?
```

The above command returns a string in the form:

```
AGILENT TECHNOLOGIES,34980A,<Serial Number>,m.mm-b.bb-f.ff-d.dd
```

m.mm = Mainframe revision number
b.bb = Boot code revision number
f.ff = Front-panel revision number
d.dd = Internal DMM revision number

Use the following command to read the firmware revision number of the module in the specified slot (be sure to dimension a string variable with at least 73 characters).

```
SYSTem:CTYPe? <slot>
```

This command returns a string in the form:

```
AGILENT TECHNOLOGIES,<Model Number>,<Serial Number>,<Firmware Rev>
```

“0” is always returned for the Serial Number field. The Firmware Revision has the form **R.RR** and indicates the revision of firmware currently in use on the specified module.

Product Firmware Updates

As new product features and enhancements become available, you can easily update your mainframe firmware to ensure optimum compatibility. The latest firmware updates are available from the Agilent 34980A product page at www.agilent.com/find/34980a (go to “Software & Firmware Downloads”).

Instrument State Storage

The instrument has five storage locations in non-volatile memory to store instrument states, numbered 1 through 5. You can assign a user-defined name to each of locations 1 through 5.

- You can store the instrument state in any of the five locations, but you can only recall a state from a location that contains a previously stored state.
- The instrument stores the state of all plug-in modules including all channel configurations, scanning setups, and Mx+B scaling values. However, note that only the measurement attributes of the currently-selected function (range, resolution, etc.) will be preserved in the stored states.
- Before recalling a stored state, the instrument verifies that the same plug-in module types are installed in each slot. If a different module type is installed, the instrument will perform the equivalent of a Factory Reset (*RST command).
- When shipped from the factory, storage locations 1 through 5 are empty. You can change the factory configuration such that a Factory Reset (*RST command) is issued when power is restored.
- You can name a location from the front panel or over the remote interface but you can recall a named state only from the front panel. The name can contain up to 12 characters. The first character *must* be a letter (A-Z), but the remaining 11 characters can be letters, numbers (0-9), or the underscore character (“_”). Blank spaces are not allowed. An error is generated if you specify a name with more than 12 characters.
- A Factory Reset (*RST command) does not affect the configurations stored in memory. Once a state is stored, it remains until it is overwritten or specifically deleted.

Front Panel Operation: Store/Recall > STORE|RECALL|DELETE|RENAME|AUTO

To rename a location, select RENAME. Press the arrow keys to move the cursor to a specific position and then turn the knob to select the desired letter or number. To clear the name of a location, change each character to “^” (starting with the rightmost character) and then press the left arrow key to move to the next character.

To automatically recall a specific location when power is restored, select AUTO. Use the knob to scroll through the available locations containing a stored state.

Remote Interface Operation: Use the following commands to store and recall instrument states.

```
*SAV {1|2|3|4|5}
*RCL {1|2|3|4|5}
```

To assign a user-defined name to a stored state to be recalled from the front panel, see the following example. From the remote interface, you can only recall a stored state using a number (1 through 5).

```
MEM:STAT:NAME 1,TEST_RACK_1
```

To configure the instrument to automatically recall location 2 when power is restored, send the following commands.

```
*SAV 2
MEM:STATE:RECALL:SELECT 2
MEM:STATE:RECALL:AUTO ON
```

Error Conditions

When the front panel ERROR annunciator turns on, one or more command syntax or hardware errors have been detected. A record of up to 20 errors can be stored in the instrument’s *error queue*. Each remote interface I/O session (i.e., GPIB, USB, LAN, etc.) has its own interface-specific error queue. Errors appear in the error queue of the I/O session that caused the error (the front panel reports errors from all I/O sessions).

For a complete listing of the error messages, see the Agilent 34980A *Programmer’s Reference* Help file, located on the *Product Reference CD-ROM*. The CD-ROM is located inside the rear cover of this manual.

- The instrument beeps once each time a command syntax or hardware error is generated.
- A special *global* error queue holds all power-on and hardware-related errors (e.g., over-temperature, Safety Interlock, etc.).

- Errors are retrieved in first-in-first-out (FIFO) order. The first error returned is the first error that was stored. Errors are cleared as you read them. Once you have read all of the interface-specific errors, the errors in the global queue are retrieved.
- Errors are cleared as you read them. When you have read all errors from the interface-specific and global error queues, the ERROR annunciator turns off and the errors are cleared.
- If more than 20 errors have occurred, the last error stored in the queue (the most recent error) is replaced with -350, "Error queue overflow". No additional errors are stored until you remove errors from the queue. If no errors have occurred when you read the error queue, the instrument responds with +0, "No error".
- The front panel reports errors from all I/O sessions as well as the global error queue.
- The interface-specific and global error queues are cleared by the *CLS (Clear Status) command and when power is cycled. The errors are also cleared when you read the error queue. The error queue is not cleared by a Factory Reset (*RST command) or an Instrument Preset (SYSTEM:PRESet command).

Front Panel Operation: View > ERROR QUEUE

Use the knob to scroll through the errors. Press the right arrow key to view the text of the error message. All errors are cleared when you exit the menu.

Remote Interface Operation: The following command reads and clears one error from the queue.

```
SYSTEM:ERRor?
```

Self-Test

A *power-on* self-test occurs automatically when you turn on the instrument. This limited test assures you that the instrument and all installed plug-in modules are operational. This self-test does *not* perform the extensive self test described below.

A *complete* self-test actually performs a series of internal tests and takes approximately 20 seconds to execute. If all tests pass, you can have high confidence that the instrument and all installed plug-in modules are operational. *This feature is available from the remote interface only.*

- If you have a 34951A Isolated DAC Module installed, the complete self-test will require an additional 15 seconds to complete per DAC module (a memory test is performed).
- The complete self-test will abort if any signals are connected to ABus1 via the rear-panel Analog Bus connector (pins 4, 5, and 9; see “[Analog Buses](#)” on page 15). Be sure to disconnect any signals from ABus1 prior to running the self-test.
- If the power-on or complete self-test fails, and error is stored in the error queue. See the Agilent 34980A *Service Guide* for more information on returning the instrument to Agilent for service.
- Following the complete self-test, the instrument issues a Factory Reset (*RST command).

Remote Interface Operation: The following command returns “+0” if the self-test is successful or “+1” if it fails.

```
*TST?
```

Front-Panel Display Control

For security reasons or for a slight increase in measurement rates, you may want to turn off the front-panel display. From the remote interface, you can also display up to 18 characters on the upper line of the front-panel display.

- You can disable the front-panel display only by sending a command from the remote interface (i.e., you cannot disable the front panel while in local operation).
- When disabled, the entire front-panel display goes dark and all display annunciators except ERROR, HOT, and Safety Interlock are disabled.
- The front-panel display is automatically enabled when power is cycled, after a Factory Reset (*RST command), or after an Instrument Preset (SYSTem:PRESet command).

- You can display a message on the front panel by sending a command from the remote interface. The instrument can display up to 18 characters on the upper line of the front-panel display; any additional characters are truncated (no error is generated). You can use letters (A-Z), numbers (0-9), and special characters like “@”, “%”, “*”, etc. Use the “#” character to display a degree symbol (°). Commas, periods, and semicolons share a display space with the preceding character, and are not considered individual characters.
- While a message is displayed on the front panel, readings from a scan or monitor are not sent to the front-panel display.
- Sending a text message to the display overrides the display state; this means that you can display a message even if the display is turned off. In addition, pressing any front-panel key will clear the text message.

Remote Interface Operation: The following command turns off the front-panel display.

```
DISPLAY OFF
```

The following command displays a message on the front panel and turns on the display if currently disabled (the quotes are not displayed).

```
DISPLAY:TEXT "SCANNING ..."
```

To clear the message displayed on the front panel (without changing the display state), send the following command.

```
DISPLAY:TEXT:CLEAR
```

Front-Panel Number Format

The instrument can show numbers on the front-panel display with periods or commas for the decimal point (radix) and thousands separator.

This feature is available from the front panel only.

- The number format is stored in non-volatile memory, and does *not* change when power has been off, after a Factory Reset (*RST command), or after an Instrument Preset (SYSTEM:PRESet command).
- When shipped from the factory, a period is used as the radix character and commas are used for the digits separator (e.g., +1.234,56 VDC).

Front Panel Operation: Utility > MISC. SETTINGS > RADIX|THOUSAND SEPARATOR

Real-Time System Clock

During a scan, the instrument stores all readings and alarms with the current time and date (based on a 24-hour clock).

- When shipped from the factory, the instrument is set to the current time and date for Greenwich Mean Time (GMT).
- The clock setting is stored in non-volatile memory, and does not change when power has been off, after a Factory Reset (*RST command), or after an Instrument Preset (SYSTEM:PRESet command).

Front Panel Operation: Utility > DATE/TIME

Remote Interface Operation: The following commands show how to set the time and date.

SYST:TIME 15,30,23.000	<i>Set time to 3:30:23.000 PM</i>
SYST:DATE 2004,11,24	<i>Set date to November 21, 2004</i>

Relay Cycle Count

The instrument has a *Relay Maintenance System* to help you predict relay end-of-life. The instrument counts the cycles on each relay in the instrument and stores the total count in non-volatile memory on each relay module. You can use this feature on any of the relay modules and the internal DMM.

- In addition to the channel relays, you can also query the count on the Analog Bus relays and bank relays.
- You can query the state of six relays associated with function selection and isolation on the internal DMM. These relays are numbered K102 through K107.
- You can reset the cycle count on any of the channel relays, Analog Bus relays, or bank relays (allowed only from remote) but the instrument must be unsecured. See [“To Unsecure the Instrument for Calibration”](#) on page 70 for more information.

Front Panel Operation: View > RELAY CYCLES

Turn the knob to read the count on the desired channel relay or Analog Bus relay.

Remote Interface Operation: To read the count on either the specified internal DMM relay or module channel relays, send the following commands.

```
DIAG:DMM:CYCLES? 2
DIAG:RELAY:CYCLES? (@1003,1013)
```

To reset the cycle count on the specified module channel relays, send the following command (the instrument must be unsecured).

```
DIAG:RELAY:CYCLES:CLEAR (@1003,1911)
```

SCPI Language Version

The instrument complies with the rules and conventions of the present version of SCPI (*Standard Commands for Programmable Instruments*). You can determine the SCPI version with which the instrument is in compliance by sending a command from the remote interface.

- You can query the SCPI version from the remote interface only.
- The SCPI version is returned in the form “YYYY.V”, where “YYYY” represents the year of the version, and “V” represents a version number for that year (for example, 1994.0).

Remote Interface Operation: `SYSTem:VERSion?`

Calibration Overview

This section gives a brief introduction to the calibration features of the instrument and plug-in modules. For a more detailed discussion of the calibration procedures, see the Agilent 34980A *Service Guide*.

Calibration Security

This feature allows you to enter a security code to prevent accidental or unauthorized calibrations of the instrument. The specified code is used to unsecure the mainframe and all installed modules. When you first receive your instrument, it is secured. Before you can calibrate the instrument, you must unsecure it by entering the correct security code.

- The security code is set to “AT34980” when the instrument is shipped from the factory. The security code is stored in non-volatile memory in the mainframe, and does not change when power has been off, after a Factory Reset (*RST command), or after an Instrument Preset (SYSTem:PRESet command).
- The security code can contain up to 12 characters. The first character must be a letter (A-Z), but the remaining 11 characters can be letters, numbers (0-9), or the underscore character (“_”). Blank spaces are not allowed. You do not have to use all 12 characters but the first character must always be a letter.

To Unsecure the Instrument for Calibration

You can unsecure the instrument from either the front panel or over the remote interface. The instrument is secured when shipped from the factory.

Once you enter a security code, that code must be used for both front-panel and remote operation. For example, if you secure the instrument from the front panel, you must use that same code to unsecure it from the remote interface.

Front Panel Operation: Utility > CALIBRATE > UNSECURE

Remote Interface Operation: To unsecure the instrument, send the following command (the factory security code is shown).

```
CAL:SECURE:STATE OFF,AT34980
```

To Secure the Instrument for Calibration

You can secure the instrument either from the front panel or over the remote interface. The instrument is secured when shipped from the factory.

Once you enter a security code, that code must be used for both front-panel and remote operation. For example, if you secure the instrument from the front panel, you must use that same code to secure it from the remote interface.

Front Panel Operation: Utility > CALIBRATE > SECURE

Remote Interface Operation: To secure the instrument, send the following command (the factory security code is shown).

```
CAL:SECURE:STATE ON,AT34980
```

To Change the Security Code

To change the security code, you must first unsecure the instrument, and then enter a new code. Make sure you have read the security code rules described on [page 70](#) before attempting to change the security code.

Front Panel Operation: Utility > CALIBRATE > SET CAL CODE

To change the security code, unsecure the instrument using the old security code. Then go back into the menu and change the code. Changing the code from the front panel also changes the security code as seen from the remote interface.

Remote Interface Operation: To change the security code, unsecure the instrument using the old security code. Then enter the new code as shown below.

```
CAL:SECURE:STATE OFF,AT34980    Unsecure with old code
CAL:SECURE:CODE SN123456789    Enter new code
```

Calibration Count

You can query the instrument to determine how many calibrations have been performed on the entire mainframe, the digital modules, or the internal DMM. Note that your instrument was calibrated before it left the factory. When you receive your instrument, be sure to read the various counts to determine the initial values.

- The calibration count is stored in non-volatile memory in the mainframe, and does not change when power has been off, after a Factory Reset (*RST command), or after an Instrument Preset (SYSTEM:PRESet command).
- The calibration counts increments up to a maximum of 4,294,967,295 after which they roll over to “0”. Since the value increments by one for each calibration point, a complete calibration may increase the value by many counts.
- The calibration count is also incremented with calibrations of DAC channels on the 34951A Isolated DAC Module and 34952A Multifunction Module.

Front Panel Operation: Utility > CALIBRATE > COUNT

Remote Interface Operation: CALibration:COUNT?

Calibration Message

The instrument allows you to store one message in calibration memory in the mainframe, a digital module, or the internal DMM. For example, you can store such information as the date when the last calibration was performed, the date when the next calibration is due, the instrument's serial number, or even the name and phone number of the person to contact for a new calibration.

- You can record a calibration message *only* from the remote interface and *only* when the instrument is unsecured. You can read the message (mainframe message only) from either the front-panel or over the remote interface. You can read the calibration message whether the instrument is secured or unsecured.
- The calibration message may contain up to 40 characters. From the front panel, you can view 18 characters of the message at a time.
- Storing a calibration message will overwrite any message previously stored in memory.
- The calibration message is stored in non-volatile memory in the mainframe, a digital module, or the internal DMM, and does not change when power has been off, after a Factory Reset (*RST command), or after an Instrument Preset (SYSTem:PRESet command).

Front Panel Operation: Utility > CALIBRATE > CAL MESSAGE

Remote Interface Operation: The following example shows how to store a message in calibration memory on the module in slot 3.

```
CAL:STRING "CAL: 21 NOV 2005",3
```

Remote Interface Configuration

This section gives information on configuring the instrument for remote interface communication. For more information on the SCPI commands available to program the instrument over the remote interface, see the *Programmer's Reference* Help file included on the Agilent 34980A *Product Reference CD-ROM*. The CD-ROM is located inside the rear cover of this manual.

The Agilent 34980A supports GPIB, USB, and LAN interfaces. All three interfaces are enabled at power on. The corresponding front-panel annunciator turns on whenever there is activity on the remote interface.

GPIB Interface You need only set the GPIB address for the instrument and connect it to your PC using a GPIB cable (sold separately).

USB Interface There is nothing to configure on your instrument for a USB connection. Just connect the instrument to your PC using a USB 2.0 cable (sold separately).

LAN Interface By default, DHCP is enabled on the instrument, which may enable network communication over the LAN interface (10BaseT/100BaseTx). You may need to set several configuration parameters as described in the LAN configuration sections that follow. A crossover LAN cable is shipped with your instrument.

NOTE

To easily configure and verify an interface connection between the 34980A and your PC, you can use the Agilent IO Libraries Suite (E2094M Agilent IO Libraries for Windows) or an equivalent. For more information about Agilent's I/O connectivity software, go to www.agilent.com/find/iolib.

- Agilent IO Libraries Suite for Windows® 98/2000/ME/XP. For more information and to install this software, see the *Automation-Ready CD*, which is shipped with your 34980A.
- Previous versions of the Agilent IO Libraries for Windows® 98/NT/2000/ME/XP. For more information and to download this software from the Web, go to www.agilent.com/find/iolib.

NOTE

For more information on connecting instruments to USB, LAN, and GPIB and how to configure and troubleshoot these interfaces, refer to the *Agilent Connectivity Guide*.

If you have installed the Agilent IO Libraries Suite, you can access the guide from the Agilent IO Libraries Control icon. Or, you can download the guide from the Web at www.agilent.com/find/connectivity.

GPIB Interface

Each device on the GPIB (IEEE-488) interface must have a unique address. You can set the instrument's address to any value between 0 and 30. The address is set to "9" when the instrument is shipped from the factory.

- Your computer's GPIB interface card has its own address. Be sure to avoid using the computer's address for any instrument on the interface bus.
- The GPIB address is stored in non-volatile memory, and does not change when power has been off, after a Factory Reset (*RST command), or after an Instrument Preset (SYSTEM:PRESet command).

Front Panel Operation: Utility > REMOTE I/O > GPIB > GPIB ADDRESS

To set the GPIB address, turn the knob (or use the number keypad) to select the desired address.

Remote Interface Operation: `SYSTEM:COMMunicate:GPIB:ADDRESS`

USB Interface

For the USB interface, no configuration parameters are required to set up the instrument. Connect your instrument to a USB port on your computer. Note that it may take several seconds for the computer to recognize and establish a connection to the instrument.

LAN Interface

By default, DHCP is enabled on the instrument, which may enable network communication over the LAN interface. You may need to set several configuration parameters as described in this section.

34980A Web Browser Interface

The Agilent 34980A provides a Web Interface which is built into the instrument. You can use this interface over LAN for remote access and control of the instrument via a Java[®]-enabled Web browser, such as Microsoft[®] Internet Explorer.

To access and use the 34980A Web Interface:

- 1 Establish a LAN interface connection from your computer to the 34980A.
- 2 Open your computer's Web browser.
- 3 Launch the 34980A Web Interface by entering the IP address of your 34980A, or its fully-qualified host name, in the browser address field.
- 4 Follow the instructions in the 34980A Web Interface's on-line Help.

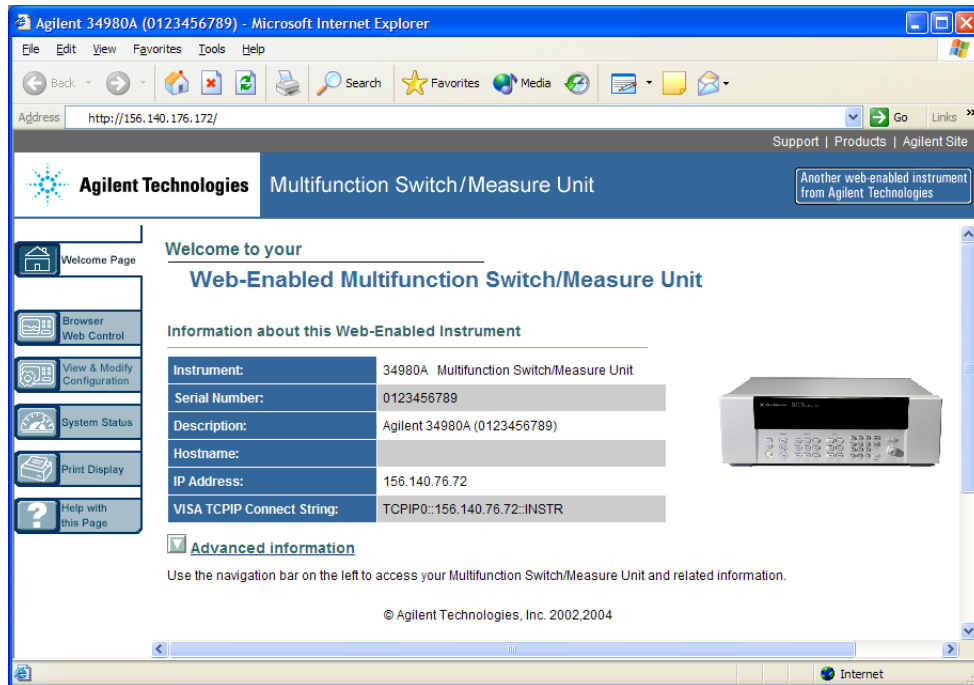

Agilent 34980A Web Interface

If desired, you can control access to the 34980A Web Interface using password protection. As shipped from the factory, no password is set. To set a password (available from the front panel only), navigate to the WEB PASSWORD menu selection from the 34980A front panel.

Utility > REMOTE I/O > LAN > LAN SETTINGS > MODIFY > . . . WEB PASSWORD

DHCP

DHCP (Dynamic Host Configuration Protocol) is a protocol for automatically assigning a dynamic IP address to a device on a network. DHCP is typically the easiest way to configure your instrument for remote communication using the LAN interface.

If you change the DHCP setting, you must cycle power on the 34980A to activate the new setting.

- When DHCP is *enabled* (factory setting), the instrument will try to obtain an IP address from a DHCP server. If a DHCP server is found, it will assign a dynamic IP address, Subnet Mask, and Default Gateway to the instrument.
- When DHCP is *disabled* or unavailable, the instrument will use the static IP address, Subnet Mask, and Default Gateway during power-on.
- If a DHCP LAN address is not assigned by a DHCP server, then a static IP will be assumed after approximately 2 minutes.
- The DHCP setting is stored in non-volatile memory, and does not change when power has been off, after a Factory Reset (*RST command), or after an Instrument Preset (SYSTem:PRESet command).

Front Panel Operation:

Utility > REMOTE I/O > LAN > LAN SETTINGS > MODIFY > DHCP

Remote Interface Operation:

```
SYSTem:COMMunicate:LAN:DHCP {OFF|ON}
```

IP Address

An Internet Protocol (IP) Address is required for all IP and TCP/IP communications with the instrument. If DHCP is enabled (factory setting), the specified static IP address is not used. However, if the DHCP server fails to assign a valid IP address, the currently configured static IP address will be used.

If you change the IP address, you must cycle power on the 34980A to activate the new setting.

- The default IP Address for the 34980A is “169.254.9.80”.

- Dot-notation addresses (“nnn.nnn.nnn.nnn” where “nnn” is a byte value) must be expressed with care, as most web software on the computer will interpret byte values with leading zeros as octal numbers. For example, “255.255.020.011” is actually equivalent to decimal “255.255.16.9” not “255.255.20.11” because “.020” is interpreted as “16” expressed in octal, and “.011” as “9”. To avoid confusion, use only decimal expressions of byte values (0 to 255), with no leading zeros.

For example, the 34980A assumes that all dot-notation addresses are expressed as decimal byte values and strips all leading zeros from these byte values. Thus, attempting to set an IP address of “255.255.020.011” will become “255.255.20.11” (a purely decimal expression). Be sure to enter the exact expression, “255.255.20.11”, in your computer web software to address the instrument. Do not use “255.255.020.011” – the computer will interpret this address differently due to the leading zeros.

- If you are planning to use a static IP address on a Corporate LAN, contact your network administrator to obtain a fixed IP address to be used exclusively for your instrument.
- The IP address is stored in non-volatile memory, and does not change when power has been off, after a Factory Reset (*RST command), or after an Instrument Preset (SYSTem:PRESet command).

Front Panel Operation:

```
Utility > REMOTE I/O > LAN > LAN SETTINGS > MODIFY > DHCP OFF >  
AUTO IP OFF > IP ADDRESS
```

Remote Interface Operation:

```
SYSTem:COMMunicate:LAN:IPAddress <address>
```

Auto-IP

The Auto-IP standard automatically assigns an IP address to the 34980A when on a network that does not have DHCP servers.

If you change the Auto-IP configuration, you must cycle power on the 34980A to activate the new setting.

- Auto-IP allocates IP addresses from the link-local address range (169.254.xxx.xxx).
- From the factory, the Auto-IP setting is enabled.
- The Auto-IP setting is stored in non-volatile memory, and does not change when power has been off, after a Factory Reset (*RST command), or after an Instrument Preset (SYSTem:PRESet command).

Front Panel Operation:

Utility > REMOTE I/O > LAN > LAN SETTINGS > MODIFY > DHCP OFF > AUTO IP

Remote Interface Operation:

```
SYSTem:COMMunicate:LAN:AUTOip {OFF|ON}
```

Subnet Mask

The instrument uses the Subnet Mask to determine if a client IP address is on the same local subnet. When a client IP address is on a different subnet, all packets must be sent to the Default Gateway. Contact your network administrator to determine if subnetting is being used and for the correct Subnet Mask.

If you change the Subnet Mask, you must cycle power on the 34980A to activate the setting.

- The default Subnet Mask for the 34980A is “255.255.0.0”.
- If DHCP is enabled, the specified Subnet Mask is not used. However, if the DHCP server fails to assign a valid IP address, the currently configured Subnet Mask will be used.
- Dot-notation addresses (“nnn.nnn.nnn.nnn” where “nnn” is a byte value) must be expressed with care, as most web software on the computer will interpret byte values with leading zeros as octal numbers. For example, “255.255.020.011” is actually equivalent to decimal “255.255.16.9” not “255.255.20.11” because “.020” is interpreted as “16” expressed in octal, and “.011” as “9”. To avoid confusion, use only decimal expressions of byte values (0 to 255), with no leading zeros.

For example, the 34980A assumes that all dot-notation addresses are expressed as decimal byte values and strips all leading zeros from these byte values. Thus, attempting to set a Subnet Mask of “255.255.020.011” will become “255.255.20.11” (a purely decimal expression). Be sure to enter the exact expression, “255.255.20.11”, in your computer web software to address the instrument. Do not use “255.255.020.011” – the the computer will interpret this address differently due to the leading zeros.

- A value of “0.0.0.0” or “255.255.255.255” indicates that subnetting is not being used.
- The Subnet Mask is stored in non-volatile memory, and does not change when power has been off, after a Factory Reset (*RST command), or after an Instrument Preset (SYSTem:PRESet command).

Front Panel Operation:

Utility > REMOTE I/O > LAN > LAN SETTINGS > MODIFY > DHCP OFF > AUTO IP OFF > ... SUBNET MASK

Remote Interface Operation:

SYSTem:COMMunicate:LAN:SMASk <mask>

Default Gateway

A Default Gateway address allows the instrument to communicate with systems that are not on the local subnet. Thus, this is the Default Gateway where packets are sent which are destined for a device not on the local subnet, as determined by the Subnet Mask setting. Contact your network administrator to determine if a gateway is being used and for the correct address.

If you change the Default Gateway, you must cycle power on the 34980A to activate the new setting.

- The default for the 34980A is “0.0.0.0” (no gateway, and subnetting is not being used).
- If DHCP is enabled, the specified Default Gateway is not used. However, if the DHCP server fails to assign a valid IP address, the currently configured Default Gateway will be used.
- Dot-notation addresses (“nnn.nnn.nnn.nnn” where “nnn” is a byte value) must be expressed with care, as most web software on the computer will interpret byte values with leading zeros as octal numbers. For example, “255.255.020.011” is actually equivalent to decimal “255.255.16.9” not “255.255.20.11” because “.020” is interpreted as “16” expressed in octal, and “.011” as “9”. To avoid confusion, use only decimal expressions of byte values (0 to 255), with no leading zeros.

For example, the 34980A assumes that all dot-notation addresses are expressed as decimal byte values and strips all leading zeros from these byte values. Thus, attempting to set a Default Gateway of “255.255.020.011” will become “255.255.20.11” (a purely decimal expression). Be sure to enter the exact expression, “255.255.20.11”, in your computer web software to address the instrument. Do not use “255.255.020.011” – the computer will interpret this address differently due to the leading zeros.

- The Default Gateway is stored in non-volatile memory, and does not change when power has been off, after a Factory Reset (*RST command), or after an Instrument Preset (SYSTem:PRESet command).

Front Panel Operation:

```
Utility > REMOTE I/O > LAN > LAN SETTINGS > MODIFY > DHCP OFF >
AUTO IP OFF > ... DEFAULT GATEWAY
```

Remote Interface Operation:

```
SYSTem:COMMunicate:LAN:GATEway <address>
```

Host Name

The Host Name is the host portion of the domain name, which is translated into an IP address.

If you change the Host Name, you must cycle power on the 34980A to activate the new setting.

- The default Host Name for the 34980A is “A-34980A-*nnn*”, where *nnn* is the instrument’s serial number representation.
- If Dynamic Domain Name System (DNS) is available on your network and your instrument uses DHCP, the Host Name is registered with the Dynamic DNS service at power-on.
- If DHCP is enabled, the DHCP server can change the specified Host Name.
- The Host Name is stored in non-volatile memory, and does not change when power has been off, after a Factory Reset (*RST command), or after an Instrument Preset (SYSTem:PRESet command).

Front Panel Operation:

```
Utility > REMOTE I/O > LAN > LAN SETTINGS > MODIFY > ... HOST NAME
```

Remote Interface Operation:

```
SYSTem:COMMunicate:LAN:HOSTname "<name>"
```

DNS Server

The Domain Name Service (DNS) is an Internet service that translates Domain names into IP addresses. Contact your network administrator to determine if DNS is being used and for the correct address.

If you change the DNS address, you must cycle power on the 34980A to activate the new setting.

- The default DNS Address for the 34980A is “0.0.0.0”.
- Dot-notation addresses (“nnn.nnn.nnn.nnn” where “nnn” is a byte value) must be expressed with care, as most web software on the computer will interpret byte values with leading zeros as octal numbers. For example, “255.255.020.011” is actually equivalent to decimal “255.255.16.9” not “255.255.20.11” because “.020” is interpreted as “16” expressed in octal, and “.011” as “9”. To avoid confusion, use only decimal expressions of byte values (0 to 255), with no leading zeros.

For example, the 34980A assumes that all dot-notation addresses are expressed as decimal byte values and strips all leading zeros from these byte values. Thus, attempting to set an IP address of “255.255.020.011” will become “255.255.20.11” (a purely decimal expression). Be sure to enter the exact expression, “255.255.20.11”, in your computer web software to address the instrument. Do not use “255.255.020.011” – the computer will interpret this address differently due to the leading zeros.

- The DNS address is stored in non-volatile memory, and does not change when power has been off, after a Factory Reset (*RST command), or after an Instrument Preset (SYSTEM:PRESet command).

Front Panel Operation:

```
Utility > REMOTE I/O > LAN > LAN SETTINGS > MODIFY > DHCP OFF >  
AUTO IP OFF > ... DNS SERVER
```

Remote Interface Operation:

```
SYSTEM:COMMunicate:LAN:DNS <address>
```

Domain Name

A domain name is a registered name on the Internet, which is translated into an IP address. *This feature is available from the remote interface only.*

If you change the Domain Name, you must cycle power on the 34980A to activate the new setting.

- If Dynamic Domain Name System (DNS) is available on your network and your instrument uses DHCP, the Domain Name is registered with the Dynamic DNS service at power-on.
- If DHCP is enabled, the DHCP server can change the specified Domain Name.
- The Domain Name is stored in non-volatile memory, and does not change when power has been off, after a Factory Reset (*RST command), or after an Instrument Preset (SYSTem:PRESet command).

Remote Interface Operation:

```
SYSTem:COMMunicate:LAN:DOMain "<name>"
```

Factory Reset State

The following tables show the state of the instrument after a *RST or SYSTem:CPON command is executed.

Measurement Configuration	Factory Reset State
Function	DC Volts
Range	Autorange
Resolution	5½ Digits
Integration Time	1 PLC
Input Resistance	10 MΩ (fixed for all DCV ranges)
Channel Labels	No Change
Channel Delay	Automatic Delay
Reading Format	Reading Only (no units, channel, time)
Sample Count	1 Sample per Trigger
Trigger Count	1 Trigger
Trigger Delay	Automatic Delay
Trigger Source	Immediate

Scanning Operations	Factory Reset State
Scan List	Empty
Reading Memory	All Readings are Cleared
Min, Max, and Average	All Statistical Data is Cleared
Sweep Count	1 Sweep
Trigger Interval	0 Seconds (immediate)
Monitor in Progress	Stopped

Mx+B Scaling	Factory Reset State
Scaling State	Off
Gain Factor ("M")	1
Offset Factor ("B")	0
Scale Label	VDC

Module Hardware	Factory Reset State
Multiplexer Modules	All Channels Open 2-Wire/1-Wire Mode: No Change
Matrix Modules	All Channels Open 2-Wire/1-Wire Mode: No Change
GP Modules	All Channels Open
RF Modules	Channels b01 and b02 Selected (b =Bank)
Microwave Modules	34946A: Channels 101 and 201 to COM 34947A: Channels 101, 201, and 301 to COM
System Control Modules	34951A: DACs=0 Vdc, Trace Waveforms Cleared 34952A: DIO Ports=Input, Count=0, DACs=0 Vdc

System-Related Operations	Factory Reset State
Display State	On
Error Queue	Errors Not Cleared
Stored States	No Change
System Date	No Change
System Time	No Change
Temperature Units	°C

Instrument Preset State

The following tables show the state of the instrument after a `SYSTEM:PRESet` command is executed.

Measurement Configuration	Preset State
Function	No Change
Range	No Change
Resolution	No Change
Integration Time	No Change
Input Resistance	No Change
Channel Labels	No Change
Channel Delay	No Change
Reading Format	No Change
Sample Count	No Change
Trigger Count	No Change
Trigger Delay	No Change
Trigger Source	No Change

Scanning Operations	Preset State
Scan List	No Change
Reading Memory	All Readings are Cleared
Min, Max, and Average	All Statistical Data is Cleared
Sweep Count	No Change
Trigger Interval	No Change
Monitor in Progress	Stopped

Mx+B Scaling	Preset State
Scaling State	No Change
Gain Factor ("M")	No Change
Offset Factor ("B")	No Change
Scale Label	No Change

Module Hardware	Preset State
Multiplexer Modules	All Channels Open 2-Wire/1-Wire Mode: No Change
Matrix Modules	All Channels Open 2-Wire/1-Wire Mode: No Change
GP Modules	All Channels Open
RF Modules	Channels b01 and b02 Selected (b =Bank)
Microwave Modules	34946A: Channels 101 and 201 to COM 34947A: Channels 101, 201, and 301 to COM
System Control Modules	34951A: DACs=0 Vdc, Trace Waveforms Cleared 34952A: DIO Ports=Input, Count=0, DACs=0 Vdc

System-Related Operations	Preset State
Display State	On
Error Queue	Errors Not Cleared
Stored States	No Change
System Date	No Change
System Time	No Change
Temperature Units	°C

2 Features and Functions

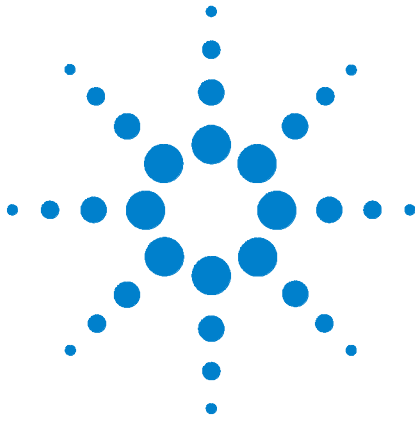

3

Introduction to the Plug-In Modules for the 34980A

Slot and Channel Addressing Scheme 90

Interconnection Solutions Overview 91

Module Considerations 92



Slot and Channel Addressing Scheme

The eight module slots in the 34980A are arranged as shown below.

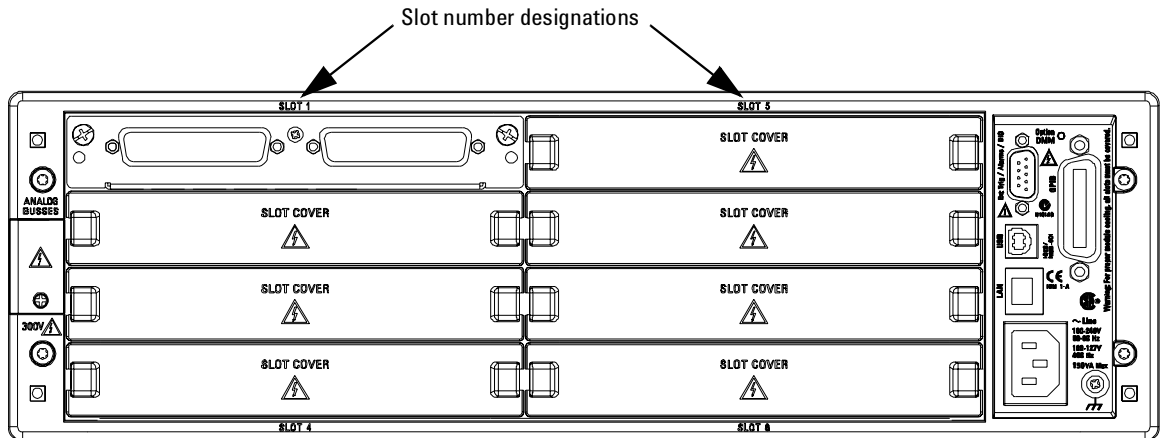

The slot and channel addressing scheme for the 34980A follows the form **sccc** where **s** is the mainframe slot number (1 through 8) and **ccc** is the three-digit channel number. Note that MUX channel numbers are derived differently from matrix modules, and channel numbers for matrix modules are derived differently between 1-wire and 2-wire configuration modes.

Displayed Number...	Means This...	Determined by...
1014	A MUX module is in slot 1, channel of interest is 14. This channel is labeled on the simplified schematics as 014 on Bank 1 of each MUX module.	MUX module channel numbers are determined by the numbers assigned to the switches on each bank. Channel numbers contain three digits.
3921	A MUX or matrix module is in slot 3, channel of interest is 921 (Analog Bus relay on ABus1)	MUX and matrix channel numbers for the Analog Bus relays are determined by the number assigned to the relays.
5304	A 34931A, 34932A, 34933A (2-wire mode) matrix module is in slot 5, crosspoint is row 3, column 4.	Matrix module (in 2-wire mode) channel numbers are derived from the crosspoint or intersection of rows and columns, columns having two digits).
2437	A 34933A matrix module in 1-wire mode is in slot 2, matrix of interest is 4, crosspoint is row 3, column 7.	34933A matrix module (in 1-wire mode) channel numbers are derived from a specific matrix number <u>and</u> the crosspoint or intersection of rows and columns on that matrix.

Interconnection Solutions Overview

Depending upon your need, you can connect your DUT to the module using one of these interconnection solutions:

- 349xxT, terminal blocks for compatible low frequency modules, offer a flexible method for connecting (300 V rated).
- Y1135, Y1136, Y1137, and Y1138, standard cables for 50-pin D-sub and 78-pin D-sub connectors (300 V rated), are available.
- Y1139A, Y1140A, Y1141A, and Y1142A, the solder cup connection kits, provide connection components for custom cabling. Fifty-pin D-sub connector is 125 V rated, and 78-pin D-sub connector is 60 V rated.

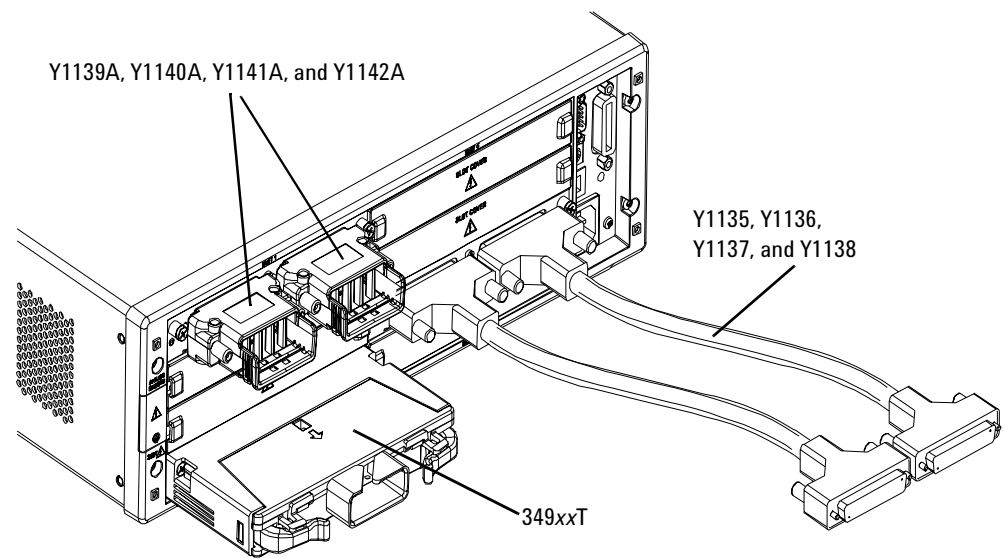

Module Considerations

This section lists important items and actions that can affect the operation of your modules.

General Considerations

NOTE

To reduce wear on the internal DMM relays, wire *like* functions on adjacent channels.

Environmental Operating Conditions

These modules are designed to operate in a temperature range of 0 °C to +55 °C with non-condensing humidity. The maximum humidity is 80% at 40 °C or higher. Do not use in locations where conductive dust or electrolytic salt dust may be present.

These modules should be operated in an indoor environment where temperature and humidity are controlled. Condensation can pose a potential shock hazard. Condensation can occur when the modules are moved from a cold to a warm environment, or if the temperature and/or humidity of the environment changes quickly.

The following table shows maximum voltage ratings for each module. If conditions change, ensure that condensation has evaporated and the instrument has thermally stabilized until pollution degree 1 conditions are restored before turning on power to the equipment.

Module	Pollution Degree 1 Specifications	Pollution Degree 2 Specifications
34921A	40 channels, 300 V rms or DC, 1 A, 60 VA per channel	40 channels, 100V rms or DC, 1 A, 60 VA per channel
34922A	70 channels, 300 V rms or DC, 1 A, 60 VA per channel	70 channels, 100 V, 1 A, 60 VA per channel
34923A	20/40/80 channels, 150 Vpeak, 0.5 A, 10 VA per channel	20/40/80 channels 100 Vpeak, 0.5 A, 10 VA per channel
34925A	40/80 channels, 80 Vpeak, 50 mA	40/80 channels, 80 Vpeak, 50 mA
34931A	Dual 4x8 matrix, 300 V rms or DC, 1 A, 60 VA per channel	Dual 4x8 matrix, 100 V rms or DC, 1 A, 60 VA per channel
34932A	Dual 4x16 matrix, 300 V rms or DC, 1 A, 60 VA per channel	Dual 4x16 matrix, 100 V rms or DC, 1 A, 60 VA per channel
34933A	Dual/quad 4x8 matrix, 150 Vpeak, 0.5 A, 10 VA per channel	Dual/quad 4x8 matrix, 100 Vpeak, 0.5 A, 10 VA per channel

Module	Pollution Degree 1 Specifications	Pollution Degree 2 Specifications
34937A	28 channels, 300 V rms or DC, 1 A, 60 VA per channel 4 channels, 250 V rms or 30 VDC, 5A, 150 VA per channel	28 channels, 100 V rms or DC, 1 A, 60 VA per channel 4 channels, 100 V rms or 30 VDC, 5A, 150 VA per channel
34938A	20 channels, 250 V rms or 30 VDC, 5 A, 150 VA per channel	20 channels, 100 V rms or 30 VDC, 5 A, 150 VA per channel
34941A	Four channels, 30 V, 0.5 A, 10 W per channel	Four channels, 30 V, 0.5 A, 10 W per channel
34946A	Dual channel, 7 V, 1 W per channel, 4 GHz or 20 GHz	Dual channel, 7 V, 1 W per channel, 4 GHz or 20 GHz
34947A	Triple channel, 7 V, 1 W per channel, 4 GHz or 20 GHz	Triple channel, 7 V, 1 W per channel, 4 GHz or 20 GHz
34951A	4 channels, 16 V, 20 mA	4 channels, 16 V, 20 mA
34952A	32 DIO channels, 42 V, 400 mA, 2 channel DAC, 12 V, 10 mA	32 DIO channels, 42 V, 400 mA, 2 channel DAC, 12 V, 10 mA

NOTE

Pollution Degree 1: No pollution or only dry, non-conductive pollution occurs. The pollution has no influence (on insulation) (IEC 61010-1 2nd Edition).

NOTE

Pollution Degree 2: Normally only non-conductive pollution occurs. Occasionally, a temporary conductivity (leakage current between isolated conductors) caused by condensation can be expected (IEC 61010-1 2nd Edition).

CAUTION

For proper module cooling, all unused slots must be covered.

Electrical Operating Conditions

WARNING

To avoid electric shock, turn off the 34980A and disconnect or de-energize all field wiring to the modules and the Analog Bus connector before removing any module or slot cover.

Transients

The 34921A, 34922A, 34923A, 34924A, 34925A, 34931A, 34932A, 34933A, 34937A, and 34938A modules are designed to safely withstand occasional transient overvoltages up to 1000 V_{peak}. Typically, these transient overvoltages result from switching inductive loads or from nearby lightning strikes. The lightning-caused transient overvoltages that may occasionally occur on mains power outlets may be as high as 2500 V_{peak}.

The 34941A, 34942A, 34945A, 34946A, 34947A, 34950A, 34951A, 34952A and 34959A modules are intended for only low-voltage applications, and should not be connected to circuits that may generate or conduct large transient voltages.

WARNING

Do not connect any of the modules directly to a mains power outlet. If it is necessary to measure a mains voltage or any circuit where a large inductive load may be switched, you must add signal conditioning elements to reduce the potential transients before they reach the module or the Analog Buses.

High Energy Sources

These modules are designed to handle inputs up to their rated currents or their rated powers, whichever is less. Under certain fault conditions, high energy sources could provide substantially more current or power than a module can handle. It is important to provide external current limiting, such as fuses, if the module inputs are connected to high-energy sources.

CAUTION

Install current limiting devices between high energy sources and the module inputs.

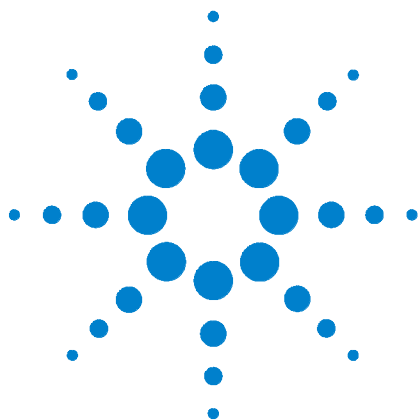

4 Low Frequency Multiplexer Switch Modules

Low Frequency Multiplexer Switch Modules	96
Measurement Functions for the MUX Modules	97
SCPI Programming Examples for the MUX Modules	98
34921A 40-Channel Armature Multiplexer with Low Thermal Offset	102
34921T Terminal Block	106
34922A 70-Channel Armature Multiplexer	107
34922T Terminal Block	111
34923A 40/80-Channel Reed Multiplexer	112
34923T-001 Terminal Block for Two- or Four-Wire Mode	117
34923T-002 Terminal Block for One-Wire Mode	120
34924A 70-Channel Reed Multiplexer	121
34924T Terminal Block	126
34925A 40/80-Channel Optically-Isolated FET Multiplexer	127
34925T-001 Terminal Block for Two- or Four-Wire Mode	132
34925T-002 Terminal Block for One-Wire Mode	135



Low Frequency Multiplexer Switch Modules

All low frequency multiplexer (MUX) switch modules feature two banks of channels that provide broad multiplexing and measuring capabilities. You can connect a MUX to an external instrument, and/or switch multiple analog signals to the internal DMM. With the 34921A, 34922A, 34923A, and the 34924A modules, you can close more than one channel in each bank simultaneously ($N:1$ configuration). As the 34925A module is protected with overvoltage circuitry, you can close only one channel in each bank at one time ($1:N$ configuration).

And, you can connect multiple MUXes to the built-in Analog Buses, which allow you to scan as many as 560 2-wire (differential) channels or 640 1-wire (single-ended) channels in one 34980A mainframe.

NOTE

Safety Interlock Analog Buses of the 34980A can carry 300 V signals. MUX and matrix modules with Analog Bus relays have a hardware Safety Interlock feature that forces Analog Bus relays open when their associated D-sub connector (faceplate) interlock pins lose continuity. This prevents signals from the Analog Buses from being present on D-sub connector pins. Optional Agilent terminal blocks automatically provide continuity for the interlock pins. When the terminal blocks are not used, you must provide continuity for the interlock pins in the DUT assembly. See pinout drawings and tables in this chapter for the location of interlock pins on the module of interest.

MUX modules with Analog Bus connections have Analog Bus relays on each of their two banks. Therefore, the interlock pins are found on both Bank 1 and Bank 2 D-sub connectors of the MUX modules.

Normally, if you attempt to connect to the Analog Buses without a terminal block or cable connected, an error is generated. The `SYSTEM:ABUS:INTERlock:SIMulate` command allows you to temporarily disable errors generated by the Safety Interlock feature and enables the Safety Interlock simulation mode. Although Safety Interlock errors are suppressed in this mode, the actual Analog Bus relays affected by the Safety Interlock are disabled as long as no terminal block or cable is connected to the module.

Measurement Functions for the MUX Modules

The MUX modules support the DMM measurement functions as shown in the following table.

Function	34921A 40-Ch Arm MUX	34922A 70-Ch Arm MUX	34923A 40-Ch Reed MUX (2-Wire)	34923A 80-Ch Reed MUX (1-Wire)	34924A 70-Ch Reed MUX	34925A 40-Ch FET MUX (2-Wire)	34925A 80-Ch FET MUX (1-Wire)
Voltage, AC/DC	Yes	Yes	Yes	Yes	Yes	Yes	Yes
Current, AC/DC	Yes ¹	No	No	No	No	No	No
Frequency/Period	Yes	Yes	Yes	Yes	Yes	Yes	Yes
Ohms 2-Wire	Yes	Yes	Yes ⁵	Yes ⁵	Yes ⁵	Yes ⁶	Yes ⁶
Ohms 4-Wire	Yes	Yes	Yes ⁵	No	Yes ⁵	Yes ⁶	No
Thermocouple	Yes ²	Yes ³	Yes ^{3,4}	Yes ^{3,4}	Yes ^{3,4}	Yes ³	Yes ³
RTD 2-Wire	Yes	Yes	Yes ⁵	Yes ⁵	Yes ⁵	No	No
RTD 4-Wire	Yes	Yes	Yes ⁵	No	Yes ⁵	Yes ⁶	No
Thermistor	Yes	Yes	Yes ⁵	Yes ⁵	Yes ⁵	No	No

¹ Direct current measurements are allowed on channels 41 through 44 only (for all other channels, external shunts are required).

² Optional 34921T Terminal Block is required for thermocouple measurements with built-in internal reference junction.

³ A fixed or external reference junction temperature is required for thermocouple measurement with this module.

⁴ Impact of higher offset voltage specification ($< 50 \mu\text{V}$) must be taken into consideration.

⁵ 1 k Ω or higher range used unless 100 Ω series resistors are bypassed on module.

⁶ 10 k Ω or higher range used for loads over approximately 300 Ω due to series resistance of FET channels.

SCPI Programming Examples for the MUX Modules

The programming examples below provide you with SCPI command examples to use for actions specific to the MUX modules.

The slot and channel addressing scheme used in these examples follow the form **sccc** where **s** is the mainframe slot number (1 through 8) and **ccc** is the three-digit channel number. For information on specific MUX channel configurations, refer to the simplified schematics contained in each MUX section of this chapter.

For complete information on the SCPI commands used to program the 34980A, refer to the Agilent 34980A Programmer's Reference contained on the 34980A Product Reference CD. For example programs, also refer to the 34980A Product Reference CD.

Opening and Closing Channels

Example: Closing and opening channels on the armature and reed MUX modules

This command closes the specified channels on a MUX module. If any channel in a bank is defined to be part of the scan list, and a scan is occurring, attempting to close another channel (including Analog Bus channels) within the same bank will result in an error. Channel closures in the other bank are allowed as long as no channels are part of the scan list.

The following commands close and open channels 13 and 15 through 18 in slot 3.

```
ROUTE:CLOSE (@3013,3015:3018)
ROUTE:OPEN (@3013,3015:3018)
```

Example: Closing channels on the FET MUX module The FET MUX module supports a 1:*N* type closure, meaning that you can have only one channel per bank closed at a time. The following command closes then automatically opens each channel from 1-19 (Bank 1) in succession, leaving channel 20 closed. Then the command continues closing and opening channels 21 to 39 (Bank 2), then leaving channel 40 closed. At the end, only channels 20 and 40 will be closed, while all other channels will have been closed and then opened. In this process, a channel will open before the next channel in succession closes, making this a “break-before-make” series.

```
ROUTE:CLOSE (@3001:3040)
```

The following command opens the closed channel on Bank 1 of a FET MUX module in slot 3, and closes channel 15 on that bank.

```
ROUTE:CLOSE (@3015)
```

Example: Closing and opening Analog Bus relays The following command connects the Analog Buses to Bank 1 (via the Analog Bus relays on Bank 1) for a module in slot 3.

```
ROUTE:CLOSE (@3911,3912,3913,3914)
ROUTE:OPEN (@3911,3912,3913,3914)
```

The Analog Bus relays (numbered s911, s912, s913, etc.) on the MUX modules are ignored if they are included in a range of channels. An error will be generated if an Analog Bus relay is specified as the first or last channel in a range of channels. For example, the following command closes all valid channels between channel 30 (slot 1) and channel 5 (slot 2). In addition, this command closes Analog Bus relay 911 on the module in slot 1 (Bank 1). Note that although the specified range of channels includes the other Analog Bus relays, they are ignored and are not closed by this command.

```
ROUTE:CLOSE (@1030:2005,1911)
```

Example: Querying channels for open or close state The following command returns a 1 (true) or 0 (false) state of channel 036 for a module in slot 3.

```
ROUTE:CLOSE (@3036)
ROUTE:CLOSE? (@3036) !Returns a 1
ROUTE:OPEN? (@3036) !Returns a 0
```

Making Measurements

Example: Making voltage measurements The following command configures channels 9 and 10 in slot 4 for DC voltage measurements, triggers the internal DMM to scan channels 9 and 10, and returns the reading. The 1 V range is selected with 1 mV resolution.

```
MEASure:VOLTage:DC? 1,0.001, (@4009,4010)
```

Example: Making voltage measurements using INITiate and FETCh?

The following program segment shows how to use the INITiate command with the CONFigure and FETCh? commands. The ROUTe:SCAN command puts channels 3 and 8 (of a module in slot 1) into the scan list (and redefines the scan list). The INITiate command scans the specified channels, and then sends the readings to memory. The FETCh? command transfers the readings from memory to the user.

```
CONFigure:VOLTage:DC 10,0.003, (@1003,1008)
ROUTE:SCAN (@1003,1008)
INITiate
FETCh?
```

Example: Making current measurements The following command configures channel 43 for a 34921A modules in slot 7 for dc current measurements, triggers the internal DMM to scan the channel, and then sends the reading to the output buffer of the 34980A. The default settings for range (autorange) and resolution (1 PLC) are used for the measurement.

```
MEASure:CURRent:DC? (@7043)
```

Configuring a Module

Example: Configuring a module for 2-wire or 1-wire mode The following command configures a MUX module in slot 4 for 1-wire mode. Because you can configure only the 34923A and 34925A MUX modules (and the 34933A matrix module) for either 2-wire or 1-wire mode, an error is generated if you send this command to a slot that does not contain one of those three modules. If you are using terminal blocks with these modules, be sure to use the corresponding 2-wire or 1-wire terminal block.

```
SYSTem:MODule:WIRE:MODE WIRE1,4
```

NOTE

When using a command to configure the system, the new configuration does not take effect until you cycle power on the 34980A.

Example: Querying the system for module Identify The following command returns the identity of the module installed in slot 7.

```
SYSTem:CTYPe? 7
```

NOTE

For the 34923A and the 34925A MUX modules, the query response may include a suffix to indicate a 1-wire configuration. For example, the response for the 34923A will be either "34923A" (differential mode) or "34923A-1W" (single-ended mode).

Querying and Clearing Cycle Count, and Resetting Modules

Example: Querying the cycle count for a relay The following command returns the cycle count on channel 7 and channel 16 for a MUX module in slot 1.

```
DIAGnostic:RELay:CYCLes? (@1007,1016)
```

NOTE

The 34925A will return 0 for relay counts because the FET relays on that module are non-mechanical and have an undefined lifetime.

Example: Clearing the cycle count for a relay The following command resets the cycle count to zero on the channels 7 and 16 for a MUX module in slot 1.

```
DIAGnostic:RELay:CYCLes:CLEar (@1007,1016)
```

Example: Resetting module(s) to power-on state The following command resets a module in slot 4 to its power-on state.

```
SYSTem:CPON 4
```

34921A 40-Channel Armature Multiplexer with Low Thermal Offset

The 34921A 40-Channel Armature Multiplexer (40-Ch Arm MUX) is divided into two banks with 20 latching armature switches (channels 1-20 and 21-40) in each. This module also offers four additional fused relays (channels 41-44) for making AC and DC current measurements with the internal DMM with no external shunts needed. These current channels feature “make-before-break” connections to ensure continuous current flow when switching from one current channel to another. The current fuses are replaceable. Refer to the 34980A Service Guide for specific information about these fuses.

This module also contains nine armature Analog Bus relays (channels 911-914, 921-924, and 931), four on each bank that can connect the bank relays to the system Analog Buses and one that connects the current relays to the current input of the DMM. Through ABus1 and ABus2 you can connect any of the channels to the internal DMM for voltage or resistance measurements. Refer to the simplified schematic on [page 104](#).

NOTE

ABus1 consists of three wires that are used for current and voltage measurements. You cannot measure current and voltage on ABus1 simultaneously.

Using program commands or the mainframe front panel, you can control each of the channel switches individually, and thus configure this module in these modes:

- two independent 20-channel 2-wire MUXes. This configuration requires neither using external wiring nor connecting through the internal Analog Buses.
- one 20-channel 4-wire MUX. This configuration requires neither using external wiring nor connecting through the internal Analog Buses. For 4-wire resistance measurements, the instrument automatically pairs channel n on Bank 1 with channel $n+20$ (Bank 2) to provide the source and sense connections. Four-wire controls occur only when doing 4-wire measurement operations through the internal DMM, such as `MEASure:FRESistance?` or scanning a channel previously configured as 4-wire.
- one 40-channel 2-wire MUX. You must use external wiring or connect through the internal Analog Bus relays for this configuration. For example, closing Analog Bus channels 913 and 923 connects Bank 1 and Bank 2 through ABus3. Or, externally you can connect COM1 to COM2 to create this configuration.

Low thermal offset voltage makes the 34921A ideal for low-level signal switching. The 34921T optional terminal block provides a built-in thermocouple reference junction that helps minimize errors due to thermal offset when you measure thermocouples.

This module has capability to scan as many as 100 channels/second using the internal DMM. With the automatic “break-before-make” connection operation, you are assured that no two signals are connected to each other during a scan. When using the module in a non-scanning mode, you can close as many channels as you wish.

This module is safety interlock protected, which means whenever the D-sub connector end of the modules is exposed, the Analog Bus relays automatically open and disconnect from the Analog Bus. For more information, refer to [page 96](#) and [page 105](#).

When power is off, all channel relays maintain state, and the Analog Bus relays open.

34921A Simplified Schematic

This drawing shows two independent 20-channel 2-wire MUXes.

NOTE: The three-digit number assigned to each switch represents the channel number.

NOTE:
Bank relays: Armature latching
Analog Bus relays: Armature non-latching

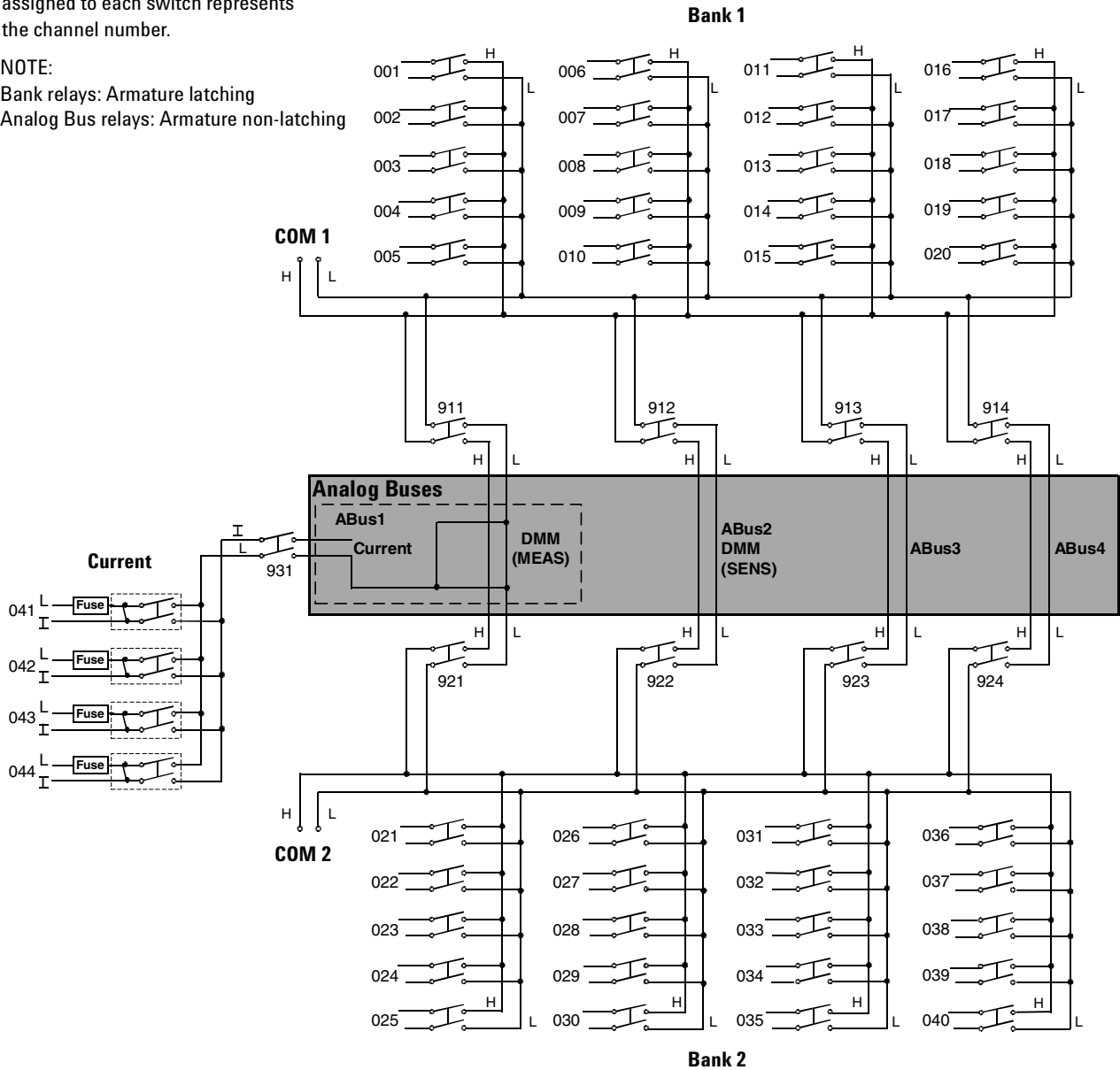

34921A D-Sub Connectors

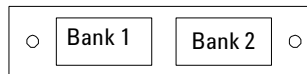

Bank 1

For orientation, the D-sub connector end of the module is facing you.

*TSIL represents Temperature Sensor Interface Line. This line is used for temperature interface only.

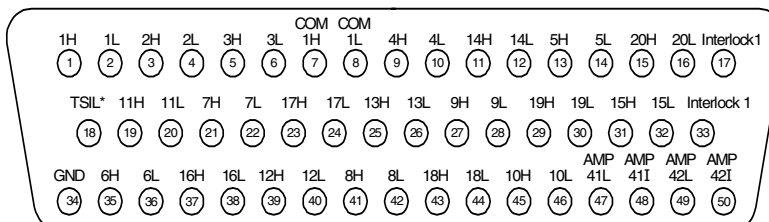

WARNING As a safety feature, interlock 1 pins (17 and 33) on Bank 1 must be shorted to enable the Bank 1 Analog Bus relays to close. The optional 34921T terminal block shorts these pins for you. This feature protects inadvertent routing of high voltages from the Analog Bus to the D-sub connector of the module.

Description	Pin	Description	Pin	Description	Pin	Description	Pin	Description	Pin
1H	1	6H	35	11H	19	16H	37	COM1 H	7
1L	2	6L	36	11L	20	16L	38	COM1 L	8
2H	3	7H	21	12H	39	17H	23	Interlock 1	17
2L	4	7L	22	12L	40	17L	24	Interlock 1	33
3H	5	8H	41	13H	25	18H	43	GND	34
3L	6	8L	42	13L	26	18L	44	TSIL*	18
4H	9	9H	27	14H	11	19H	29	AMP 41L	47
4L	10	9L	28	14L	12	19L	30	AMP 41I	48
5H	13	10H	45	15H	31	20H	15	AMP 42L	49
5L	14	10L	46	15L	32	20L	16	AMP 42I	50

Bank 2

*TSIL represents Temperature Sensor Interface Line. This line is used for temperature interface only.

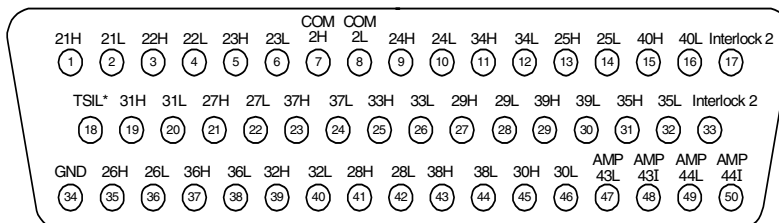

WARNING As a safety feature, interlock 2 pins (17 and 33) on Bank 2 must be shorted to enable the Bank 2 Analog Bus relays to close. The optional 34921T terminal block shorts these pins for you. This feature protects inadvertent routing of high voltages from the Analog Bus to the D-sub connector of the module.

Description	Pin	Description	Pin	Description	Pin	Description	Pin	Description	Pin
21H	1	26H	35	31H	19	36H	37	COM2 H	7
21L	2	26L	36	31L	20	36L	38	COM2 L	8
22H	3	27H	21	32H	39	37H	23	Interlock 2	17
22L	4	27L	22	32L	40	37L	24	Interlock 2	33
23H	5	28H	41	33H	25	38H	43	GND	34
23L	6	28L	42	33L	26	38L	44	TSIL*	18
24H	9	29H	27	34H	11	39H	29	AMP 43L	47
24L	10	29L	28	34L	12	39L	30	AMP 43I	48
25H	13	30H	45	35H	31	40H	15	AMP 44L	49
25L	14	30L	46	35L	32	40L	16	AMP 44I	50

34921T Terminal Block

This terminal block with screw-type connections is labeled with the model number and the abbreviated module name. In addition, space is available on the label for you to write the slot number.

NOTE All modules that connect to the internal DMM are interlock protected. This means that when an installed module is exposed (no terminal block or cable is connected), the Analog Bus relays are open and disconnected from the Analog Buses. See [page 96](#) for further information.

The 34921T is the only terminal block that provides an isothermal block with temperature reference for thermocouple measurements.

CAUTION When wiring the terminal block via cables to the mainframe, make sure the cables are connected to the correct connector. The cables provide communication and power to the temperature sensor on the 34921T terminal block. If cabling is not correct, an error may occur indicating that the 34921A module is not fully operational.

The 34980A Product Reference CD (shipped with the instrument) contains a the 34921T Wiring Log for you to document your wiring configuration for this module. You can open the wiring log file in Microsoft® Excel® or Adobe® Acrobat® format.

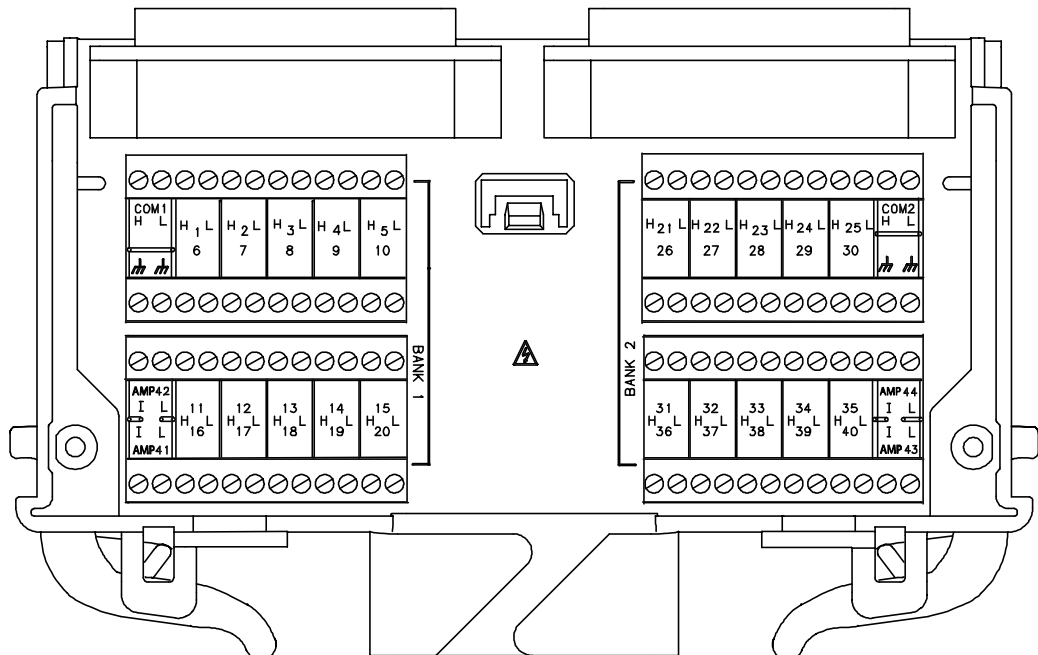

34922A 70-Channel Armature Multiplexer

The high-density 34922A 70-Channel Armature Multiplexer (70-Ch Arm MUX) is divided into two banks with 35 latching armature switches (channels 1-35 and 36-70) in each. This module also contains eight armature Analog Bus relays (channels 911-914 and 921-924), four on each bank that can connect the bank relays to the system Analog Buses. Through ABus1 and ABus2 you can connect any of the channels to the internal DMM for voltage or resistance measurements. Refer to the simplified schematic on [page 108](#).

Using program commands or the mainframe front panel, you can control each of the channel switches individually, and thus configure this module in these modes:

- two independent 35-channel 2-wire MUXes. This configuration requires neither using external wiring nor connecting through the internal Analog Buses.
- one 35-channel 4-wire MUX. This configuration requires neither using external wiring nor connecting through the internal Analog Buses. For 4-wire resistance measurements, the instrument automatically pairs channel n on Bank 1 with channel $n+35$ (Bank 2) to provide the source and sense connections. Four-wire controls occur only when doing 4-wire measurement operations through the internal DMM, such as MEASure:FRESistance? or scanning a channel previously configured as 4-wire.
- one 70-channel 2-wire MUX. You must use external wiring or connect through the internal Analog Bus relays for this configuration. For example, closing Analog Bus channels 913 and 923 connects Bank 1 and Bank 2 through ABus3. Or, externally you can connect COM1 to COM2 to create this configuration.

This module has capability to scan as many as 100 channels/second using the internal DMM. With the automatic “break-before-make” connection operation, you are assured that no two signals are connect to each other during a scan. When using the module in a non-scanning mode, you can close as many channels as you wish.

This module is interlock protected, which means whenever the D-sub connector end of the modules is exposed, the Analog Bus relays automatically open and disconnect from the Analog Bus. For more information, refer to [page 96](#) and [page 109](#).

When the power is off, all channel relays maintain state, and the Analog Bus relays open.

34922A Simplified Schematic

This drawing shows two independent 35-channel 2-wire MUXes.

NOTE: The three-digit number assigned to each switch represents the channel number.

NOTE:

Bank relays: Armature latching

Analog Bus relays: Armature non-latching

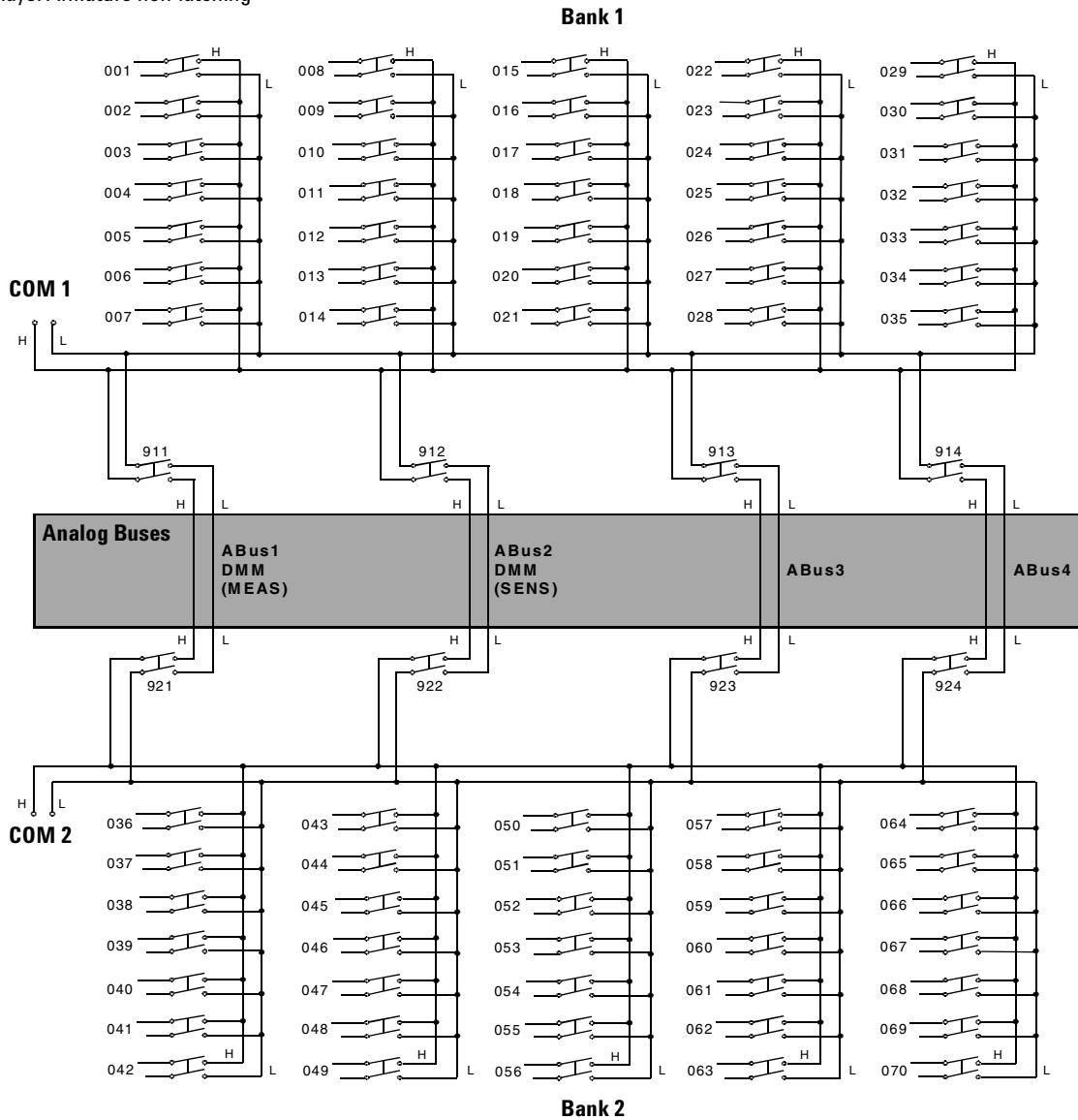

34922A D-Sub Connectors

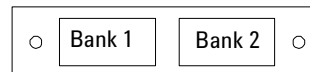

Bank 1

For orientation, the D-sub connector end of the module is facing you.

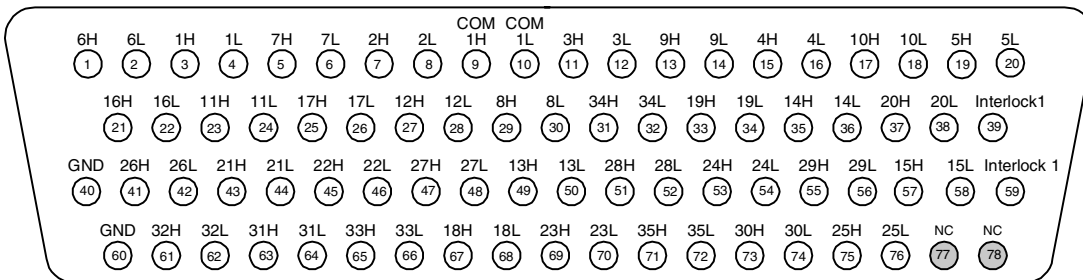

Description	Pin	Description	Pin	Description	Pin	Description	Pin	Description	Pin	Description	Pin
1H	3	8H	29	15H	57	22H	45	29H	55	COM1 H	9
1L	4	8L	30	15L	58	22L	46	29L	56	COM1 L	10
2H	7	9H	13	16H	21	23H	69	30H	73	Interlock 1	39
2L	8	9L	14	16L	22	23L	70	30L	74	Interlock 1	59
3H	11	10H	17	17H	25	24H	53	31H	63	GND	40
3L	12	10L	18	17L	26	24L	54	31L	64	GND	60
4H	15	11H	23	18H	67	25H	75	32H	61	No Connect	77
4L	16	11L	24	18L	68	25L	76	32L	62	No Connect	78
5H	19	12H	27	19H	33	26H	41	33H	65		
5L	20	12L	28	19L	34	26L	42	33L	66		
6H	1	13H	49	20H	37	27H	47	34H	31		
6L	2	13L	50	20L	38	27L	48	34L	32		
7H	5	14H	35	21H	43	28H	51	35H	71		
7L	6	14L	36	21L	44	28L	52	35L	72		

WARNING As a safety feature, interlock 1 pins (39 and 59) on Bank 1 must be shorted to enable the Bank 1 Analog Bus relays to close. The optional 34922T terminal block shorts these pins for you. This feature protects inadvertent routing of high voltages from the Analog Buses to the D-sub connector of the module.

4 Low Frequency Multiplexer Switch Modules

Bank 2

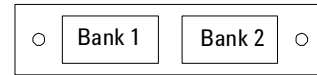

For orientation, the D-sub connector end of the module is facing you.

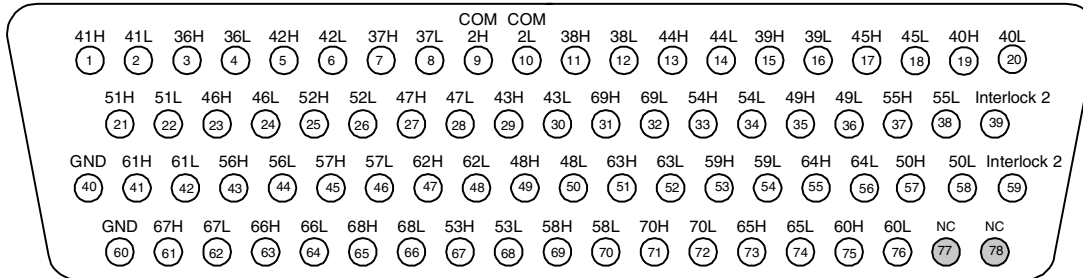

Description	Pin	Description	Pin	Description	Pin	Description	Pin	Description	Pin	Description	Pin
36H	3	43H	29	50H	57	57H	45	64H	55	COM2 H	9
36L	4	43L	30	50L	58	57L	46	64L	56	COM2 L	10
37H	7	44H	13	51H	21	58H	69	65H	73	Interlock 2	39
37L	8	44L	14	51L	22	58L	70	65L	74	Interlock 2	59
38H	11	45H	17	52H	25	59H	53	66H	63	GND	40
38L	12	45L	18	52L	26	59L	54	66L	64	GND	60
39H	15	46H	23	53H	67	60H	75	67H	61	No Connect	77
39L	16	46L	24	53L	68	60L	76	67L	62	No Connect	78
40H	19	47H	27	54H	33	61H	41	68H	65		
40L	20	47L	28	54L	34	61L	42	68L	66		
41H	1	48H	49	55H	37	62H	47	69H	31		
41L	2	48L	50	55L	38	62L	48	69L	32		
42H	5	49H	35	56H	43	63H	51	70H	71		
42L	6	49L	36	56L	44	63L	52	70L	72		

WARNING

As a safety feature, interlock 2 pins (39 and 59) on Bank 2 must be shorted to enable the Bank 2 Analog Bus relays to close. The optional 34922T terminal block shorts these pins for you. This feature protects inadvertent routing of high voltages from the Analog Buses to the D-sub connector of the module.

34922T Terminal Block

This terminal block with solder-type connections is labeled with the model number and the abbreviated module name. In addition, space is available on the label for you to write the slot number.

NOTE All modules that connect to the internal DMM are interlock protected. This means that when an installed module is exposed (no terminal block or cable is connected), the Analog Bus relays are open and disconnected from the Analog Buses. See [page 96](#) for further information.

The 34980A Product Reference CD (shipped with the instrument) contains a the 34922T Wiring Log for you to document your wiring configuration for this module. You can open the wiring log file in Microsoft® Excel® or Adobe® Acrobat® format.

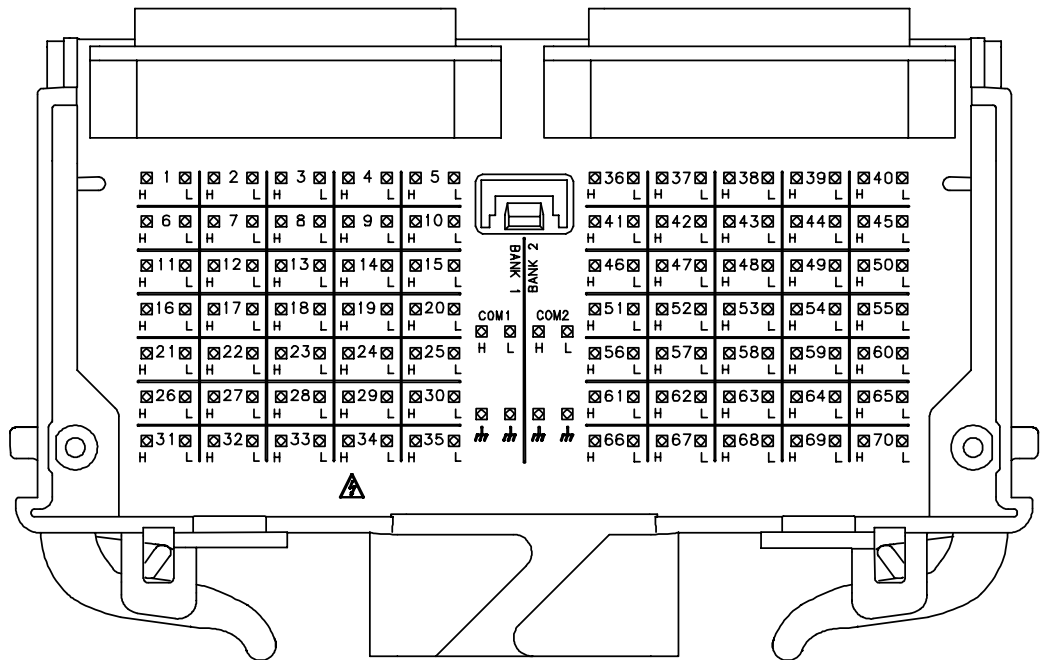

34923A 40/80-Channel Reed Multiplexer

The 34923A 40/80-Channel Reed Multiplexer (40/80-Ch Reed MUX) is divided into two equal banks of non-latching reed switches. This module also contains eight armature Analog Bus relays (channels 911-914 and 921-924), four on each bank that can connect the bank relays to the system Analog Buses. You can connect any of the channels to the internal DMM through ABus1 and ABus2 for voltage or resistance measurements.

Using program commands or the mainframe front panel, you can control each of the channel switches individually, and configure this module for differential (2-wire or 4-wire) or single-ended (1-wire) mode. Refer to the simplified schematics on [page 114](#) and [page 118](#).

If you are using an optional Agilent 349xxT terminal block to connect your DUT to this module be sure to use the terminal block that corresponds to your module configuration. Use the 34923T-001 terminal block for 2-wire or 4-wire configuration. Use the 34923T-002 terminal block for 1-wire configuration. Refer to drawings on [page 117](#) and [page 120](#).

You can confirm the mode in which your module is configured by using the `SYSTEM:CTYPE? <slot number>` program command. This command returns the identity of the plug-in module in the specified slot.

NOTE

Whenever you change from 2- or 4-wire mode to 1-wire mode, or the reverse, you must cycle power on the 34980A for the configuration to take effect.

Two-Wire Mode

- two independent 20-channel 2-wire MUXes. This configuration requires neither using external wiring nor connecting through the internal Analog Buses.
- one 40-channel, 2-wire MUX. You must use external wiring or connect through the internal Analog Buses for this configuration.

In 2-wire mode, you can close no more than 20 channels simultaneously due to power dissipation. These 20 channels are split 10 to a bank. However, note that Analog Bus relays count half as much as channel relays in that total. For example, with one Analog Bus relay closed, you can close up to a maximum of 19 channel relays. If you try to close more than the allowed number of channels, you will receive an error message.

Four-Wire Mode

This 20-channel 4-wire MUX This configuration requires neither using external wiring nor connecting through the internal Analog Buses. For 4-wire resistance measurements, the instrument automatically pairs channel n on Bank 1 with channel $n + 20$ (Bank 2) to provide the source and sense connections. Four-wire controls occur only when doing 4-wire measurement operations through the internal DMM, such as `MEASure:FRESistance?` or scanning a channel previously configured as 4-wire.

One-Wire Mode

- two independent 40-channel 1-wire MUXes. This configuration requires neither using external wiring nor connecting through the internal Analog Buses.
- one 80-channel 1-wire MUX. You must use external wiring or connect through the internal Analog Bus for this configuration.

NOTE

Because all bank relays supply only HI signals, you can apply a LOW signal through COM1 L or COM2 L when you are making 2-wire resistance measurements in 1-wire mode.

In 1-wire mode, you can close no more than 40 channels simultaneously due to power dissipation. These channels are split 20 to a bank. For example, with one Analog Bus relay closed you can close up to a maximum of 39 channel relays. If you try to close more than the allowed number of channels, you will receive an error message.

In all modes, this module has capability to scan as many as 500 channels/second using the internal DMM. With the automatic “break-before-make” connection operation, you are assured that no two signals are connect to each other during a scan.

This module is interlock protected, which means whenever the D-sub connector end of the modules is exposed, the Analog Bus relays immediately open and disconnect from the Analog Bus. For more information, refer to [page 96](#), and [page 116](#) or [page 119](#).

CAUTION

Because user-attached reactive loads and backplane parasitic capacitance may result in high in-rush currents, 100 Ω in-rush resistors protect the reed relays from damage and performance degradation. Therefore, you must consider these resistors when you are designing a measurement. Refer to the simplified schematics on [page 114](#) and [page 118](#).

4 Low Frequency Multiplexer Switch Modules

Lifetime of relays is severely degraded as current or voltage goes up. If higher voltage is being switched, limits on source current are recommended.

When the power is off, all channel and Analog Bus relays open.

34923A Simplified Schematic for Two- or Four-Wire Mode

This drawing shows two independent 20-channel 2-wire MUXes. To change configuration modes, use the `SYSTEM:MODULE:WIRE:MODE` command.

NOTE: The three-digit number assigned to each switch represents the channel number.

NOTE:
 Bank relays: Reed non-latching
 Analog Bus relays: Armature non-latching.

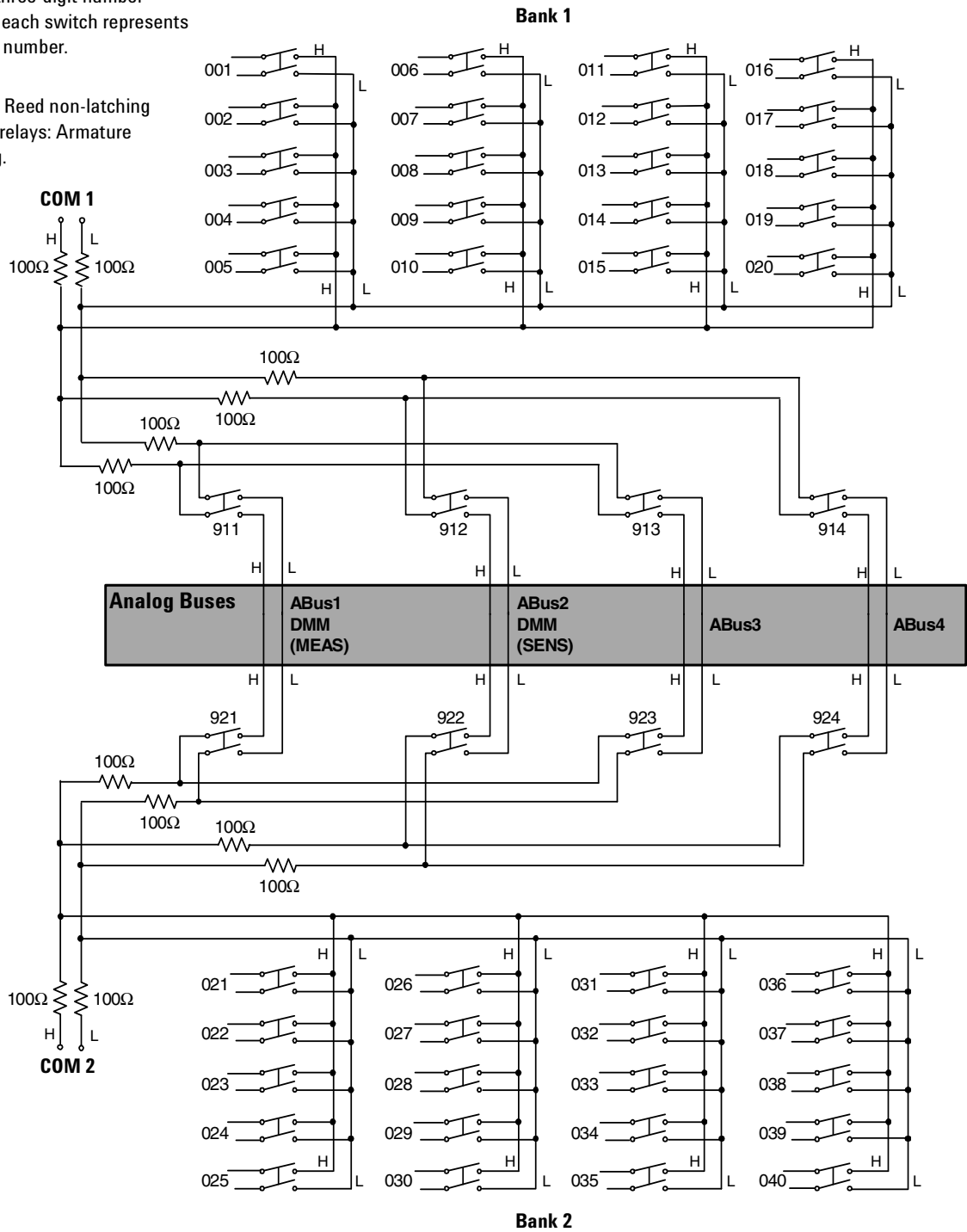

34923A D-Sub Connectors for Two- or Four-Wire Mode

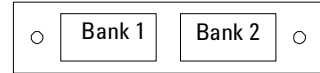

Bank 1

For orientation, the D-sub connector end of the module is facing you.

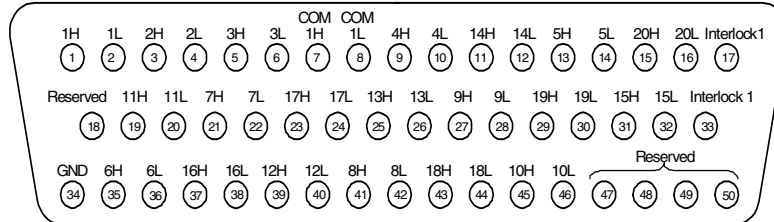

WARNING As a safety feature, interlock 1 pins (17 and 33) on Bank 1 must be shorted to enable the Bank 1 Analog Bus relays to close. The optional 34923T-001 (for 2-wire) terminal block shorts these pins for you. This feature protects inadvertent routing of high voltages from the Analog Bus to the D-sub connector of the module.

Description	Pin	Description	Pin	Description	Pin	Description	Pin	Description	Pin
1H	1	6H	35	11H	19	16H	37	COM1 H	7
1L	2	6L	36	11L	20	16L	38	COM1 L	8
2H	3	7H	21	12H	39	17H	23	Interlock 1	17
2L	4	7L	22	12L	40	17L	24	Interlock 1	33
3H	5	8H	41	13H	25	18H	43	GND	34
3L	6	8L	42	13L	26	18L	44	Reserved	18
4H	9	9H	27	14H	11	19H	29	Reserved	47
4L	10	9L	28	14L	12	19L	30	Reserved	48
5H	13	10H	45	15H	31	20H	15	Reserved	49
5L	14	10L	46	15L	32	20L	16	Reserved	50

Bank 2

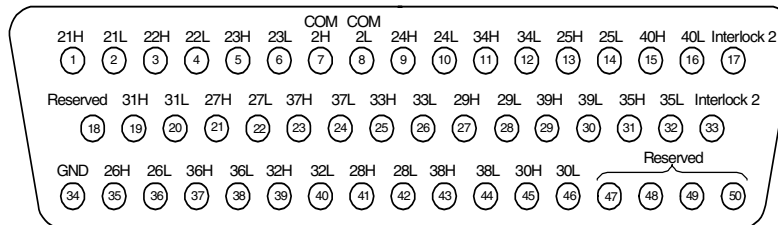

WARNING As a safety feature, interlock 2 pins (17 and 33) on Bank 2 must be shorted to enable the Bank 2 Analog Bus relays to close. The optional 34923T-001 (for 2-wire) shorts these pins for you. This feature protects inadvertent routing of high voltages from the Analog Buses to the D-sub connector of the module.

Description	Pin	Description	Pin	Description	Pin	Description	Pin	Description	Pin
21H	1	26H	35	31H	19	36H	37	COM2 H	7
21L	2	26L	36	31L	20	36L	38	COM2 L	8
22H	3	27H	21	32H	39	37H	23	Interlock 2	17
22L	4	27L	22	32L	40	37L	24	Interlock 2	33
23H	5	28H	41	33H	25	38H	43	GND	34
23L	6	28L	42	33L	26	38L	44	Reserved	18
24H	9	29H	27	34H	11	39H	29	Reserved	47
24L	10	29L	28	34L	12	39L	30	Reserved	48
25H	13	30H	45	35H	31	40H	15	Reserved	49
25L	14	30L	46	35L	32	40L	16	Reserved	50

34923T-001 Terminal Block for Two- or Four-Wire Mode

This terminal block with screw-type connections is labeled with the model number and the abbreviated module name. In addition, space is available on the label for you to write the slot number.

NOTE All modules that connect to the internal DMM are interlock protected. This means that when an installed module is exposed (no terminal block or cable is connected), the Analog Bus relays are open and disconnected from the Analog Buses. See [page 96](#) for further information.

NOTE If you are using an Agilent terminal block to connect your DUT to this module be sure to use the 34923T-001 terminal block that corresponds to the 2- or 4-wire configuration mode. An error will not be generated if you have installed a terminal block that doesn't match the present module configuration.

The 34980A Product Reference CD (shipped with the instrument) contains a the 34923T (2-wire mode) Wiring Log for you to document your wiring configuration for this module. You can open the wiring log file in Microsoft® Excel® or Adobe® Acrobat® format.

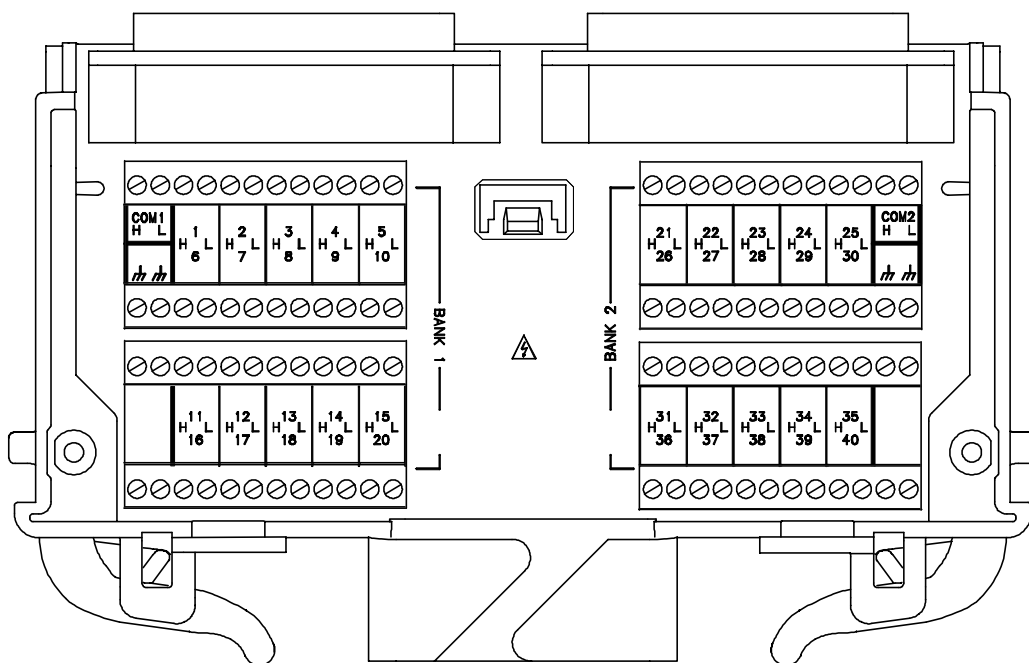

34923A Simplified Schematic for One-Wire Mode

This drawing shows two independent 40-channel 1-wire MUXes. To change configuration modes, use the `SYSTEM:MODULE:WIRE:MODE` command.

NOTE: The three-digit number assigned to each switch represents the channel number.

NOTE:
Bank relays: Reed non-latching
Analog Bus relays: Armature non-latching

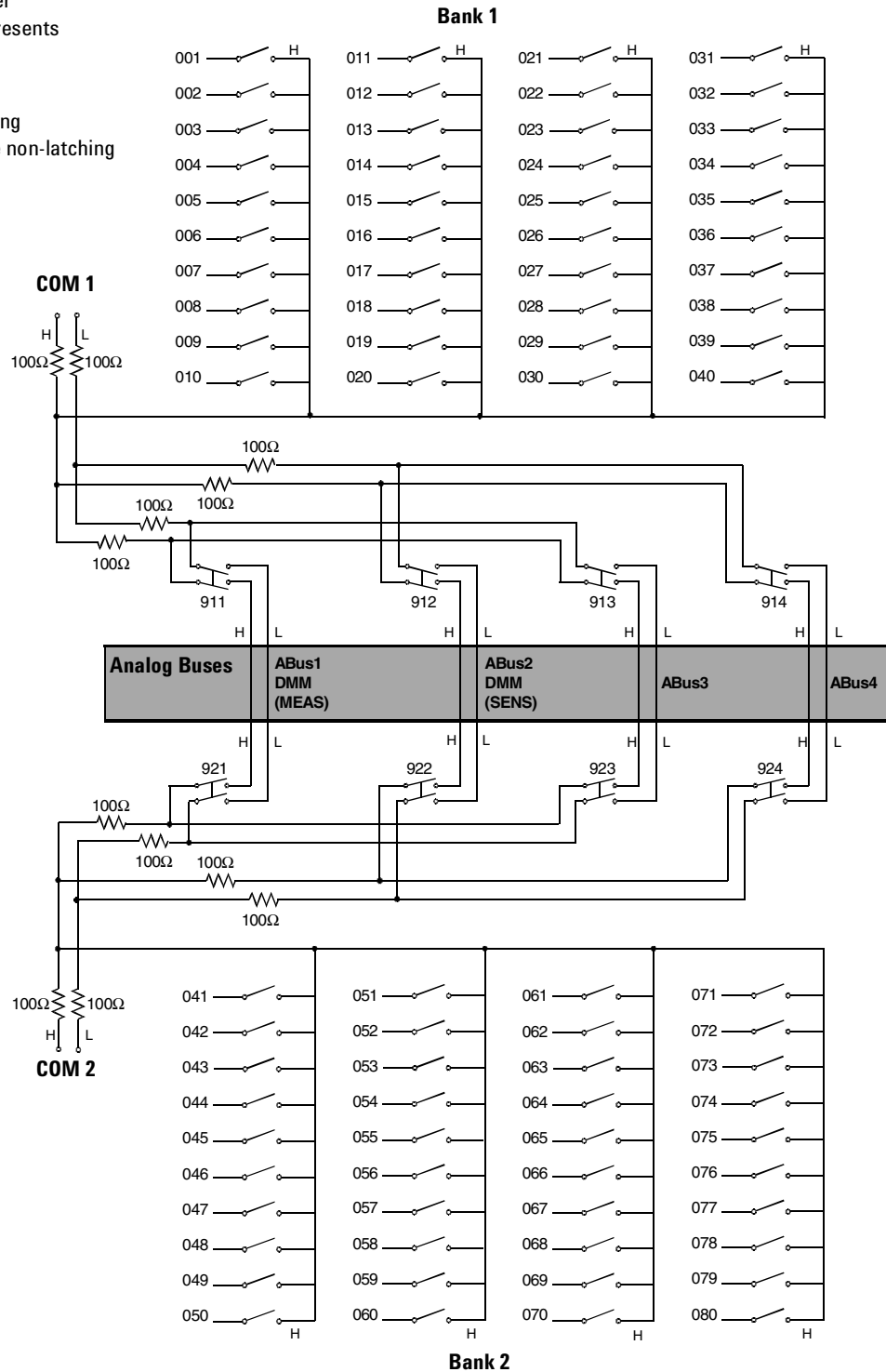

34923A D-Sub Connectors for One-Wire Mode

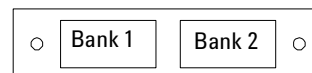

Bank 1

For orientation, the D-sub connector end of the module is facing you.

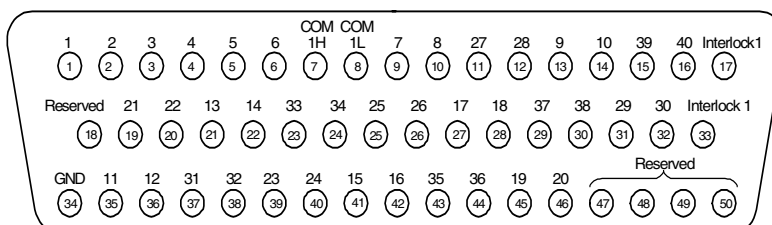

WARNING As a safety feature, interlock 1 pins (17 and 33) on Bank 1 must be shorted to enable the Bank 1 Analog Bus relays to close. The optional 34923T-002 (for 1-wire) shorts these pins for you. This feature protects inadvertent routing of high voltages from the Analog Bus to the D-sub connector of the module.

Description	Pin	Description	Pin	Description	Pin	Description	Pin	Description	Pin
1	1	11	35	21	19	31	37	COM1 H	7
2	2	12	36	22	20	31	38	COM1 L	8
3	3	13	21	23	39	33	23	Interlock 1	17
4	4	14	22	24	40	34	24	Interlock 1	33
5	5	15	41	25	25	35	43	GND	34
6	6	16	42	26	26	36	44	Reserved	18
7	9	17	27	27	11	37	29	Reserved	47
8	10	18	28	28	12	38	30	Reserved	48
9	13	19	45	29	31	39	15	Reserved	49
10	14	20	46	30	32	40	16	Reserved	50

Bank 2

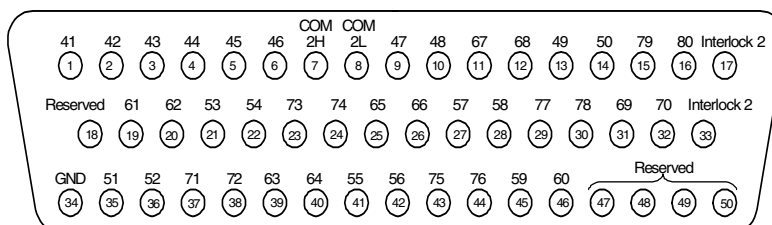

WARNING As a safety feature, interlock 2 pins (17 and 33) on Bank 2 must be shorted to enable the Bank 2 Analog Bus relays to close. The optional 34923T-002 (for 1-wire) shorts these pins for you. This feature protects inadvertent routing of high voltages from the Analog Buses to the D-sub connector of the module.

Description	Pin	Description	Pin	Description	Pin	Description	Pin	Description	Pin
41	1	51	35	61	19	71	37	COM2 H	7
42	2	52	36	62	20	72	38	COM2 L	8
43	3	53	21	63	39	73	23	Interlock 2	17
44	4	54	22	64	40	74	24	Interlock 2	33
45	5	55	41	65	25	75	43	GND	34
46	6	56	42	66	26	76	44	Reserved	18
47	9	57	27	67	11	77	29	Reserved	47
48	10	58	28	68	12	78	30	Reserved	48
49	13	59	45	69	31	79	15	Reserved	49
50	14	60	46	70	32	80	16	Reserved	50

34923T-002 Terminal Block for One-Wire Mode

This terminal block with screw-type connections is labeled with the model number and the abbreviated module name. In addition, space is available on the label for you to write the slot number.

NOTE All modules that connect to the internal DMM are interlock protected. This means that when an installed module is exposed (no terminal block or cable is connected), the Analog Bus relays are open and disconnected from the Analog Buses. See [page 96](#) for further information.

NOTE If you are using an Agilent terminal block to connect your DUT to this module be sure to use the 34923T-002 terminal block that corresponds to the 1-wire configuration mode. An error will not be generated if you have installed a terminal block that doesn't match the present module configuration.

The 34980A Product Reference CD (shipped with the instrument) contains a the 34923T (1-wire mode) Wiring Log for you to document your wiring configuration for this module. You can open the wiring log file in Microsoft® Excel® or Adobe® Acrobat® format.

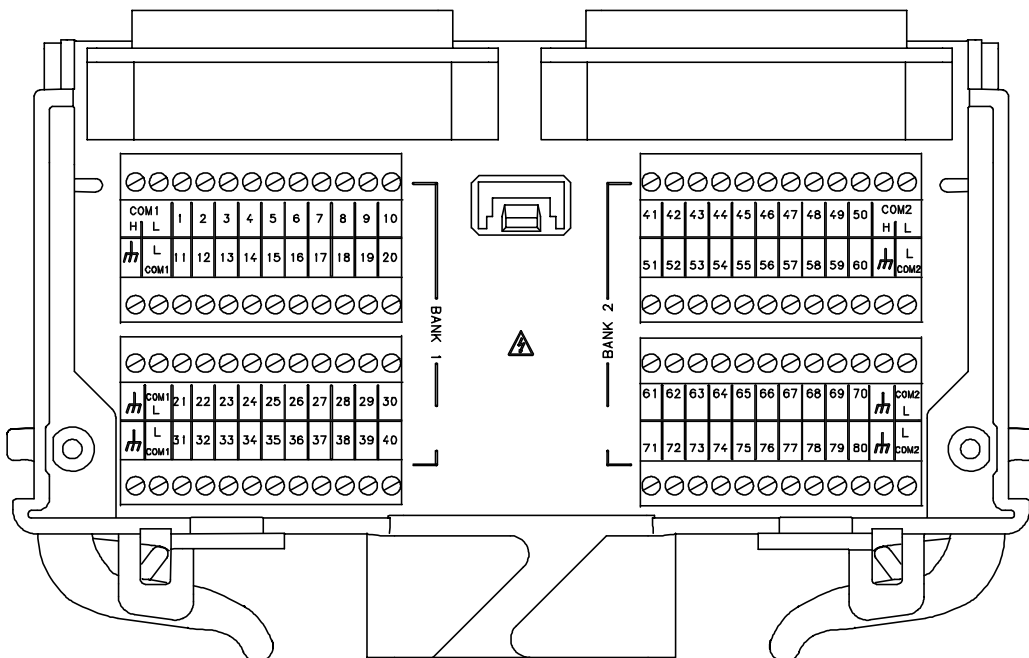

34924A 70-Channel Reed Multiplexer

The high-density 34924A 70-Channel Reed Multiplexer (70-Ch Reed MUX) is divided into two banks with 35 non-latching reed switches (channels 1-35 and 36-70) in each. This module also contains eight armature Analog Bus relays (channels 911-914 and 921-924), four on each bank that can connect the bank relays to the system Analog Buses. Through ABus1 and ABus2 you can connect any of the channels to the system DMM for voltage or resistance measurements. See the simplified schematic on [page 123](#).

Using program commands or the mainframe front panel, you can control each of the channel switches individually, and thus configure this module in the modes listed below.

- two independent 35-channel 2-wire MUXes. This configuration requires neither using external wiring nor connecting through the internal Analog Buses.
- one 70-channel, 2-wire MUX. You must use external wiring or connect through the internal Analog Buses for this configuration.
- one 35-channel 4-wire MUX. This configuration requires neither using external wiring nor connecting through the internal Analog Buses. For 4-wire resistance measurements, the instrument automatically pairs channel n on Bank 1 with channel $n+35$ (Bank 2) to provide the source and sense connections. Four-wire controls occur only when doing 4-wire measurement operations through the internal DMM, such as MEASure:FRESistance? or scanning a channel previously configured as 4-wire.

In 2-wire mode, you can close no more than 20 channels simultaneously due to power dissipation. These 20 channels are split 10 to a bank. However, note that Analog Bus relays count half as much as channel relays in that total. For example, with one Analog Bus relay closed, you can close up to a maximum of 19 channel relays. If you try to close more than the allowed number of channels, you will receive an error message.

In all modes, this module has capability to scan as many as 500 channels/second using the internal DMM. With the automatic “break-before-make” connection operation, you are assured that no two signals are connect to each other during a scan.

CAUTION

Because user-attached reactive loads and backplane parasitic capacitance may result in high in-rush currents, 100 Ω in-rush resistors protect the reed relays from damage and performance degradation. Therefore, you must consider these resistors when you are designing a measurement. Refer to the simplified schematic on [page 123](#).

4 Low Frequency Multiplexer Switch Modules

This module is interlock protected, which means whenever the D-sub connector end of the modules is exposed, the Analog Bus relays immediately open and disconnect from the Analog Bus. For more information, refer to [page 96](#).

Lifetime of relays is severely degraded as current or voltage goes up. If higher voltage is being switched, limits on source current are recommended.

When the power is off, all channel and Analog Bus relays open.

34924A Simplified Schematic

This drawing shows two independent 35-channel 2-wire MUXes.

NOTE: The three-digit number assigned to each switch represents the channel number.

NOTE:

Bank relays: Reed non-latching

Analog Bus relays: Armature non-latching

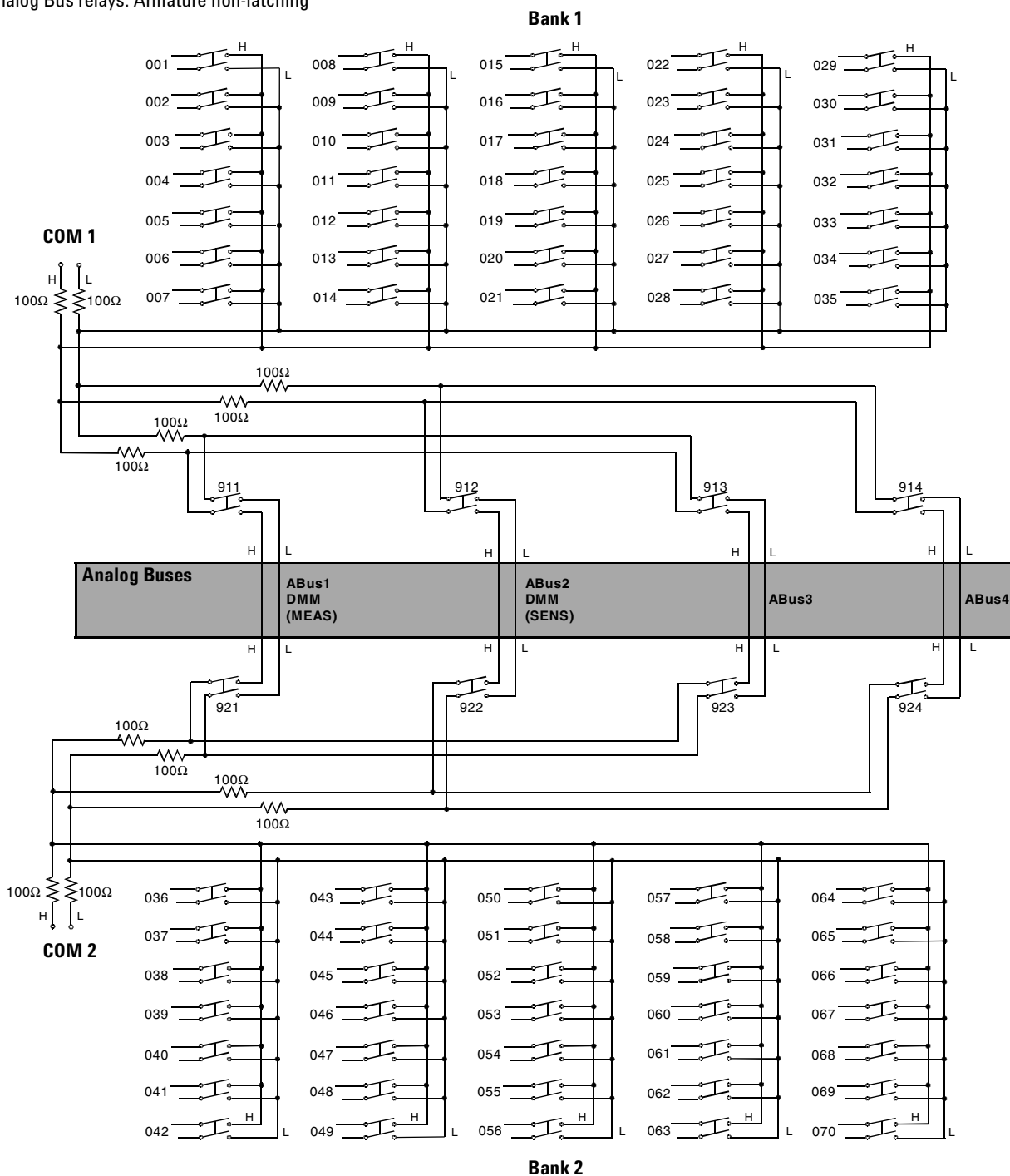

34924A D-Connectors

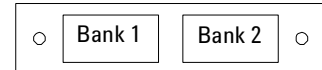

Bank 1

For orientation, the D-sub connector end of the module is facing you.

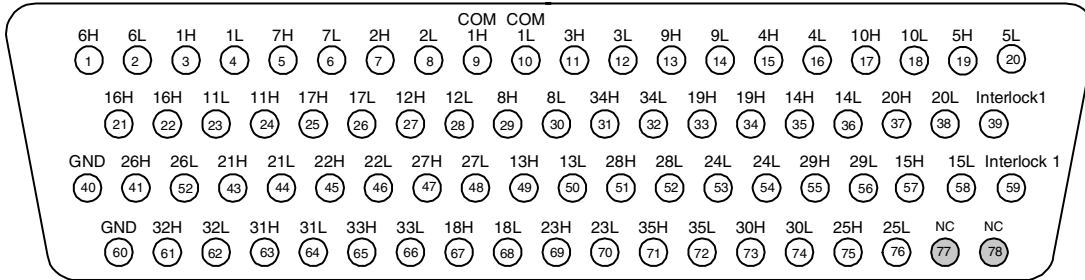

Description	Pin	Description	Pin	Description	Pin	Description	Pin	Description	Pin	Description	Pin
1H	3	8H	29	15H	57	22H	45	29H	55	COM1 H	9
1L	4	8L	30	15L	58	22L	46	29L	56	COM1 L	10
2H	7	9H	13	16H	21	23H	69	30H	73	Interlock 1	39
2L	8	9L	14	16L	22	23L	70	30L	74	Interlock 1	59
3H	11	10H	17	17H	25	24H	53	31H	63	GND	40
3L	12	10L	18	17L	26	24L	54	31L	64	GND	60
4H	15	11H	23	18H	67	25H	75	32H	61	No Connect	77
4L	16	11L	24	18L	68	25L	76	32L	62	No Connect	78
5H	19	12H	27	19H	33	26H	41	33H	65		
5L	20	12L	28	19L	34	26L	42	33L	66		
6H	1	13H	49	20H	37	27H	47	34H	31		
6L	2	13L	50	20L	38	27L	48	34L	32		
7H	5	14H	35	21H	43	28H	51	35H	71		
7L	6	14L	36	21L	44	28L	52	35L	72		

WARNING As a safety feature, interlock 1 pins (39 and 59) on Bank 1 must be shorted to enable the Bank 1 Analog Bus relays to close. The optional 34924T terminal block shorts these pins for you. This feature protects inadvertent routing of high voltages from the Analog Buses to the D-sub connector of the module.

Bank 2

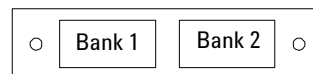

For orientation, the D-sub connector end of the module is facing you.

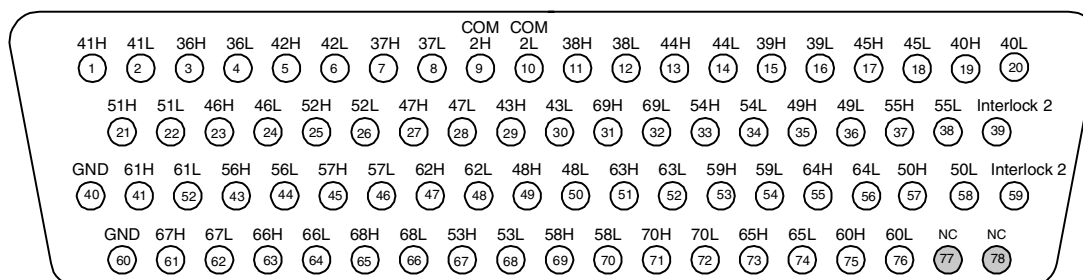

Description	Pin	Description	Pin	Description	Pin	Description	Pin	Description	Pin	Description	Pin
36H	3	43H	29	50H	57	57H	45	64H	55	COM2 H	9
36L	4	43L	30	50L	58	57L	46	64L	56	COM2 L	10
37H	7	44H	13	51H	21	58H	69	65H	73	Interlock 2	39
37L	8	44L	14	51L	22	58L	70	65L	74	Interlock 2	59
38H	11	45H	17	52H	25	59H	53	66H	63	GND	40
38L	12	45L	18	52L	26	59L	54	66L	64	GND	60
39H	15	46H	23	53H	67	60H	75	67H	61	No Connect	77
39L	16	46L	24	53L	68	60L	76	67L	62	No Connect	78
40H	19	47H	27	54H	33	61H	41	68H	65		
40L	20	47L	28	54L	34	61L	42	68L	66		
41H	1	48H	49	55H	37	62H	47	69H	31		
41L	2	48L	50	55L	38	62L	48	69L	32		
42H	5	49H	35	56H	43	63H	51	70H	71		
42L	6	49L	36	56L	44	63L	52	70L	72		

WARNING As a safety feature, interlock 2 pins (39 and 59) on Bank 2 must be shorted to enable the Bank 2 Analog Bus relays to close. The optional 34924T terminal block shorts these pins for you. This feature protects inadvertent routing of high voltages from the Analog Buses to the D-sub connector of the module.

34924T Terminal Block

This terminal block with solder-type connections is labeled with the model number and the abbreviated module name. In addition, space is available on the label for you to write the slot number.

NOTE

All modules that connect to the internal DMM are interlock protected. This means that when an installed module is exposed (no terminal block or cable is connected), the Analog Bus relays are open and disconnected from the Analog Buses. See [page 96](#) for further information.

The 34980A Product Reference CD (shipped with the instrument) contains a the 34924T Wiring Log for you to document your wiring configuration for this module. You can open the wiring log file in Microsoft® Excel® or Adobe® Acrobat® format.

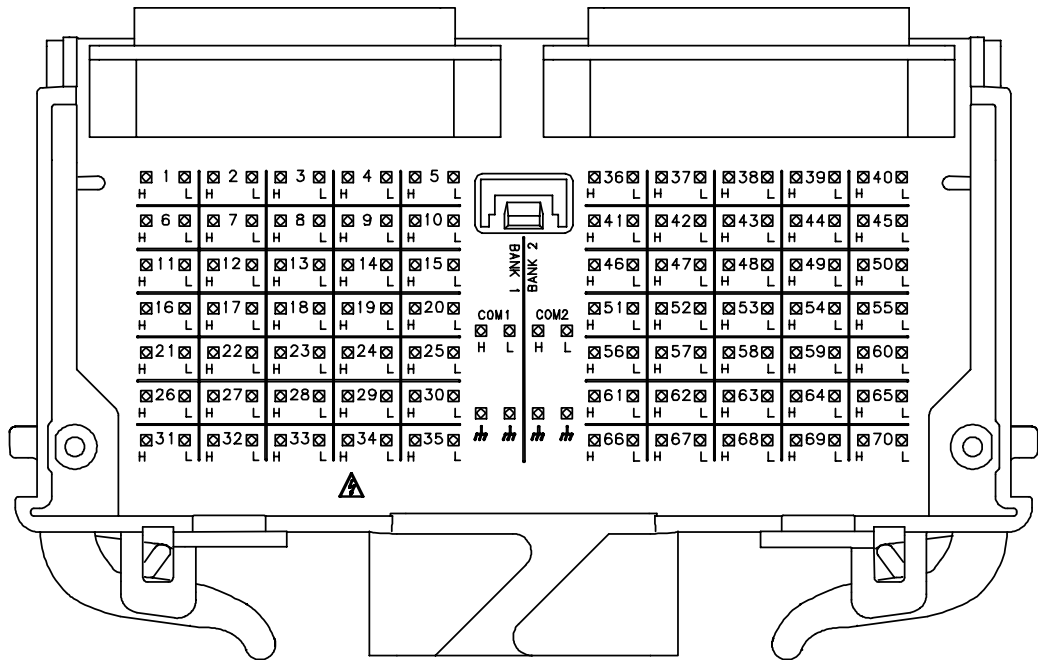

34925A 40/80-Channel Optically-Isolated FET Multiplexer

The 34925A 40/80-Channel Optically-Isolated FET Multiplexer (40/80-Ch FET MUX) module is a high-speed and high-density FET MUX for high throughput production test. This module is divided into two equal banks of non-latching FET switches. This module also contains four armature Analog Bus relays. Through ABus1 and ABus2 you can connect any of the channels to the internal DMM for voltage or resistance measurements. When the power is off, all channel and Analog Bus relays open.

Using program commands or the mainframe front panel, you can control each of the FET channel switches individually, and configure this module for differential (2-wire or 4-wire) or single-ended (1-wire) mode. Refer to the simplified schematics on [page 130](#) and [page 133](#).

If you are using an Agilent 349xxT terminal block to connect your DUT to this module, be sure to use the terminal block that corresponds to your module configuration mode. Use the 34925T-001 terminal block for differential mode (2-wire or 4-wire configuration). Use the 34925T-002 terminal block for single-ended mode (1-wire configuration). Refer to drawings on [page 132](#) and [page 135](#).

You can confirm the mode in which your module is configured by using the `SYSTem:CTYPe? <slot number>` program command. This command returns the identity of the plug-in module in the specified slot.

NOTE

Whenever you change from 2- or 4-wire mode to 1-wire mode, or the reverse, you must cycle power on the 34980A for the configuration to take effect.

Two-Wire

- two independent 20-channel 2-wire MUXes. This configuration requires neither using external wiring nor connecting through the internal Analog Bus relays.
- one 40-channel, 2-wire MUX. You must use external wiring or connect through the Analog Bus relays to for this configuration.

Four-Wire

- one 20-channel 4-wire MUX. This configuration requires using neither external wiring nor connecting through the internal Analog Buses. For 4-wire resistance measurements, the instrument automatically pairs channel n on Bank 1 with channel $n+20$ (Bank 2) to provide the source and sense connections. Four-wire controls occur only when doing 4-wire measurement operations through the internal DMM, such as `MEASure:FRESistance?` or scanning a channel previously configured as 4-wire.

One-Wire

- two independent 40-channel 1-wire MUXes. This configuration requires neither using external wiring nor connecting through the Analog Bus relays.
- one 80-channel 1-wire MUX. You must use external wiring or connect through the Analog Bus relays for this configuration.

NOTE

Because all bank relays supply only HI signals, you can apply a LOW signal through COM1 L or COM2 L when you are making 2-wire resistance measurements in 1-wire mode.

Interlock Protection

This module is interlock protected, which means whenever the D-sub connector end of the modules is exposed, the Analog Bus relays immediately open and disconnect from the Analog Buses. For more information, refer to [page 96](#).

Overvoltage Protection

This module also features high voltage detection (< 100 V) and current limiting circuitry to protect the FET relays. This circuitry senses current flows from input overvoltages. These overvoltages may come from either the MUX input or from the Analog Buses. In addition, each channel is also protected from input overvoltages with a resistor.

When overvoltage is detected, all relays (Analog Bus and FET) are opened. While in the overvoltage state, any attempts to close any Analog Bus or FET switch, results in an error status response from the module.

Once in the overvoltage state, you must restore normal module operation with one of these actions:

- using the `SYSTem:CPON <slot>` command. This affects only the module specified.

- using the *RST command. This command resets the mainframe and all installed modules to the Factory configuration. This affects all installed modules.
- cycling system power. This affects all installed modules.

If the overvoltage situation is not resolved, clearing the overvoltage will result in a new overvoltage event occurring immediately.

Further FET protection is assured only as one channel in each bank is closed at any time. Thus this module will operate as only a 1:N MUX module. For more information about FET channel closures, refer to [page 98](#).

34925A Simplified Schematic for Two- or Four-Wire Mode

This drawing shows two independent 20-channel 2-wire MUXes. To change configuration modes, use the `SYSTEM:MODULE:WIRE:MODE` command.

NOTE: The three-digit number assigned to each switch represents the channel number.

NOTE:

Bank relays: FET non-latching

Analog Bus relays: Armature non-latching

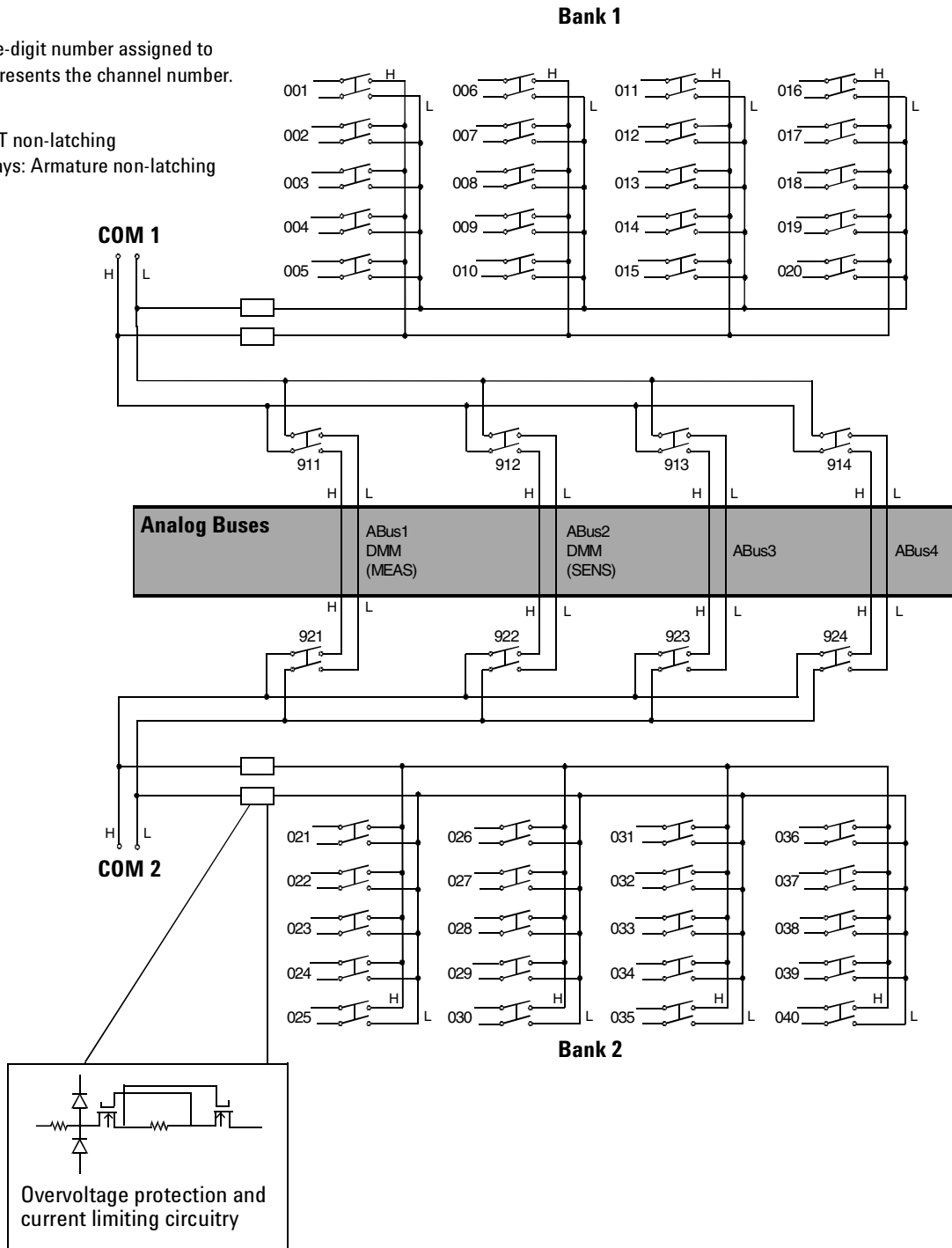

34925A D-Sub Connectors for Two- or Four-Wire Mode

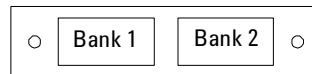

Bank 1

For orientation, the D-sub connector end of the module is facing you.

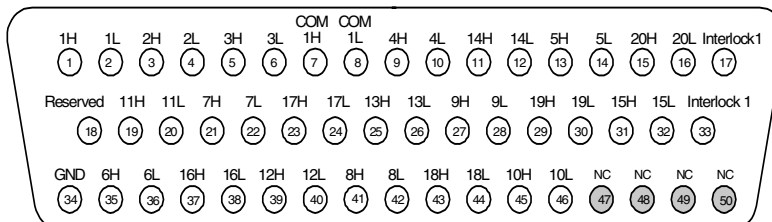

WARNING As a safety feature, interlock 1 pins (17 and 33) on Bank 1 must be shorted to enable the Bank 1 Analog Bus relays to close. The optional 34925T-001 (for 2-wire) terminal block shorts these pins for you. This feature protects inadvertent routing of high voltages from the Analog Bus to the D-sub connector of the module.

Description	Pin	Description	Pin	Description	Pin	Description	Pin	Description	Pin
1H	1	6H	35	11H	19	16H	37	COM1 H	7
1L	2	6L	36	11L	20	16L	38	COM1 L	8
2H	3	7H	21	12H	39	17H	23	Interlock 1	17
2L	4	7L	22	12L	40	17L	24	Interlock 1	33
3H	5	8H	41	13H	25	18H	43	Reserved	18
3L	6	8L	42	13L	26	18L	44	GND	34
4H	9	9H	27	14H	11	19H	29	No Connect	47
4L	10	9L	28	14L	12	19L	30	No Connect	48
5H	13	10H	45	15H	31	20H	15	No Connect	49
5L	14	10L	46	15L	32	20L	16	No Connect	50

Bank 2

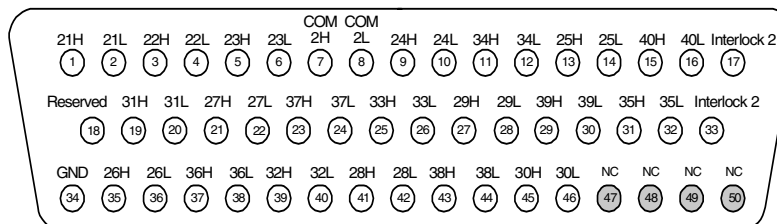

WARNING As a safety feature, interlock 2 pins (17 and 33) on Bank 2 must be shorted to enable the Bank 2 Analog Bus relays to close. The optional 34925T-001 (for 2-wire) terminal block shorts these pins for you. This feature protects inadvertent routing of high voltages from the Analog Buses to the D-sub connector of the

Description	Pin	Description	Pin	Description	Pin	Description	Pin	Description	Pin
21H	1	26H	35	31H	19	36H	37	COM2 H	7
21L	2	26L	36	31L	20	36L	38	COM2 L	8
22H	3	27H	21	32H	39	37H	23	Interlock 2	17
22L	4	27L	22	32L	40	37L	24	Interlock 2	33
23H	5	28H	41	33H	25	38H	43	Reserved	18
23L	6	28L	42	33L	26	38L	44	GND	34
24H	9	29H	27	34H	11	39H	29	No Connect	47
24L	10	29L	28	34L	12	39L	30	No Connect	48
25H	13	30H	45	35H	31	40H	15	No Connect	49
25L	14	30L	46	35L	32	40L	16	No Connect	50

34925T-001 Terminal Block for Two- or Four-Wire Mode

This terminal block with screw-type connections is labeled with the model number and the abbreviated module name. In addition, space is available on the label for you to write the slot number.

NOTE All modules that connect to the internal DMM are interlock protected. This means that when an installed module is exposed (no terminal block or cable is connected), the Analog Bus relays are open and disconnected from the Analog Buses. See [page 96](#) for further information.

NOTE If you are using an Agilent terminal block to connect your DUT to this module be sure to use the 34925T-001 terminal block that corresponds to the 2- or 4-wire configuration mode. An error will not be generated if you have installed a terminal block that doesn't match the present module configuration.

The 34980A Product Reference CD (shipped with the instrument) contains a the 34925T (2-wire mode) Wiring Log for you to document your wiring configuration for this module. You can open the wiring log file in Microsoft® Excel® or Adobe® Acrobat® format.

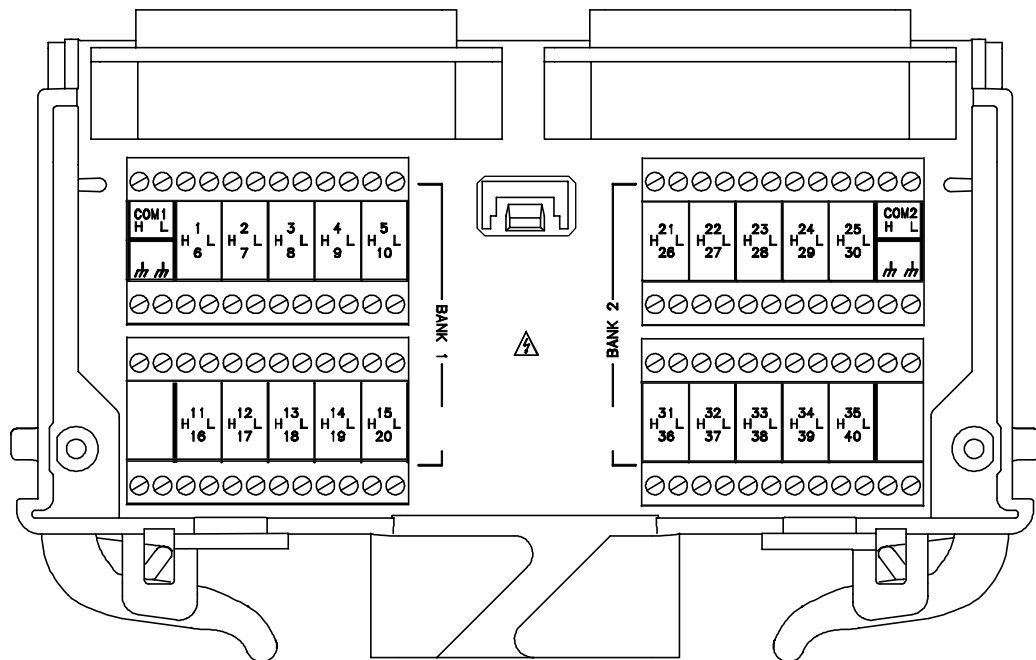

34925A Simplified Schematic for One-Wire Mode

This drawing shows two independent 40-channel, 1-wire MUXes. To change configuration modes, use the SYSTEM:MODULE:WIRE:MODE command.

NOTE: The three-digit number assigned to each switch represents the channel number.

NOTE:
Bank relays: FET non-latching
Analog Bus relays: Armature non-latching

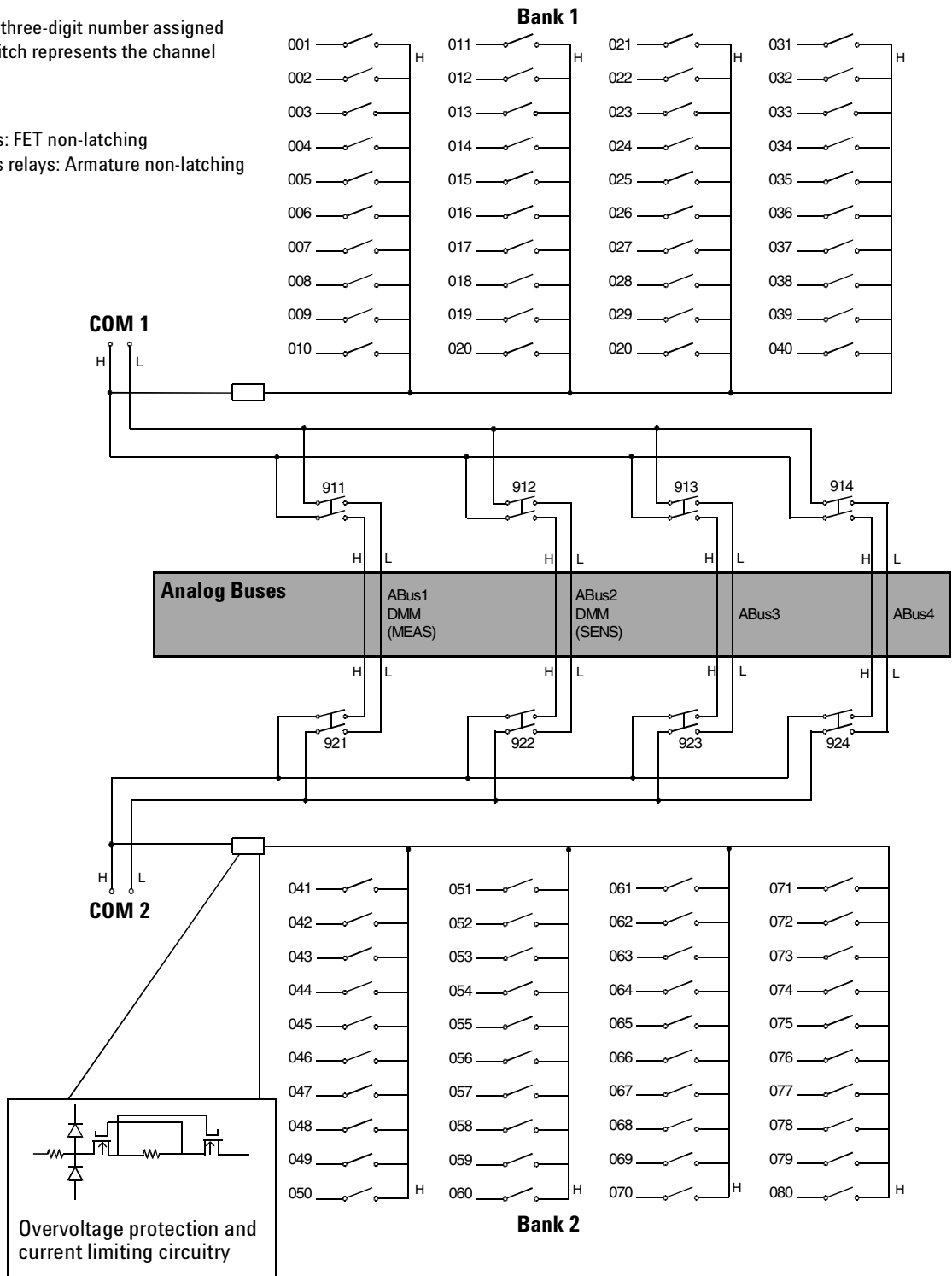

34925A D-Sub Connectors for One-Wired Mode

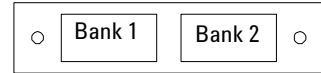

Bank 1

For orientation, the D-sub connector end of the module is facing you.

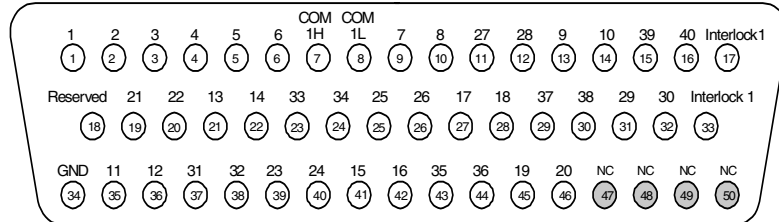

WARNING As a safety feature, interlock 1 pins (17 and 33) on Bank 1 must be shorted to enable the Bank 1 Analog Bus relays to close. The optional 34925T-002 (for 1-wire) terminal block shorts these pins for you. This feature protects inadvertent routing of high voltages from the Analog Bus to the D-sub connector of the module.

Description	Pin	Description	Pin	Description	Pin	Description	Pin	Description	Pin
1	1	11	35	21	19	31	37	COM1 H	7
2	2	12	36	22	20	32	38	COM1 L	8
3	3	13	21	23	39	33	23	Interlock 1	17
4	4	14	22	24	40	34	24	Interlock 1	33
5	5	15	41	25	25	35	43	Reserved	18
6	6	16	42	26	26	36	44	GND	34
7	9	17	27	27	11	37	29	No Connect	47
8	10	18	28	28	12	38	30	No Connect	48
9	13	19	45	29	31	39	15	No Connect	49
10	14	20	46	30	32	40	16	No Connect	50

Bank 2

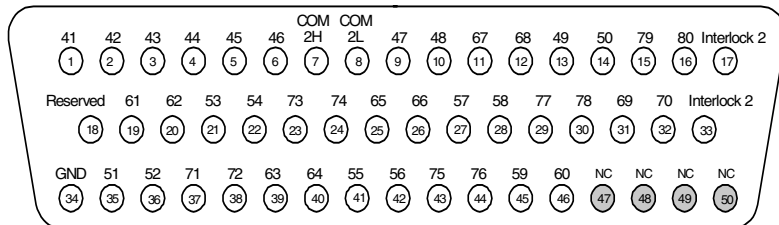

WARNING As a safety feature, interlock 2 pins (17 and 33) on Bank 2 must be shorted to enable the Bank 2 Analog Bus relays to close. The optional 34925T-002 (for 1-wire) terminal block shorts these pins for you. This feature protects inadvertent routing of high voltages from the Analog Buses to the D-sub connector of the

Description	Pin	Description	Pin	Description	Pin	Description	Pin	Description	Pin
41	1	51	35	61	19	71	37	COM2 H	7
42	2	52	36	62	20	72	38	COM2 L	8
43	3	53	21	63	39	73	23	Interlock 2	17
44	4	54	22	64	40	74	24	Interlock 2	33
45	5	55	41	65	25	75	43	Reserved	18
46	6	56	42	66	26	76	44	GND	34
47	9	57	27	67	11	77	29	No Connect	47
48	10	58	28	68	12	78	30	No Connect	48
49	13	59	45	69	31	79	15	No Connect	49
50	14	60	46	70	32	80	16	No Connect	50

34925T-002 Terminal Block for One-Wire Mode

This terminal block with screw-type connections is labeled with the model number and the abbreviated module name. In addition, space is available on the label for you to write the slot number.

NOTE All modules that connect to the internal DMM are interlock protected. This means that when an installed module is exposed (no terminal block or cable is connected), the Analog Bus relays are open and disconnected from the Analog Buses. See [page 96](#) for further information.

NOTE If you are using an Agilent terminal block to connect your DUT to this module be sure to use the 34925T-002 terminal block that corresponds to the 1-wire configuration mode. An error will not be generated if you have installed a terminal block that doesn't match the present module configuration.

The 34980A Product Reference CD (shipped with the instrument) contains a the 34925T (1-wire mode) Wiring Log for you to document your wiring configuration for this module. You can open the wiring log file in Microsoft® Excel® or Adobe® Acrobat® format.

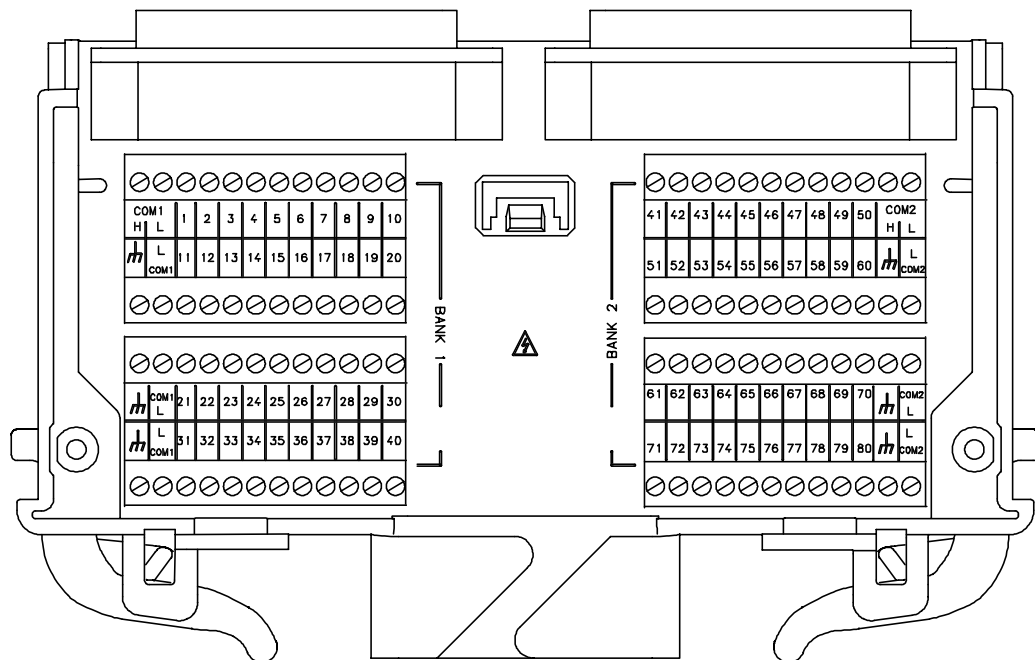

4 Low Frequency Multiplexer Switch Modules

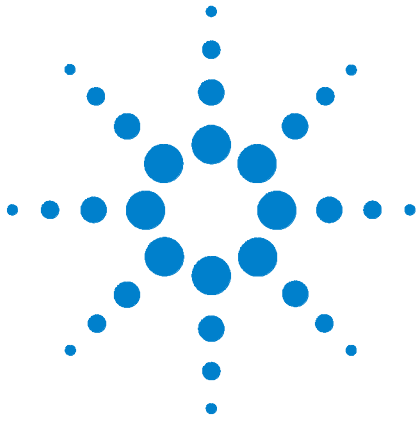

5 Matrix Switch Modules

Matrix Switch Modules	138
SCPI Programming Examples for the Matrix Modules	139
Linking Multiple Matrix Modules	142
34931A Dual 4x8 Armature Matrix	144
34931T Terminal Block	147
34932A Dual 4x16 Armature Matrix	149
34932T Terminal Block	152
34933A Dual/Quad 4x8 Reed Matrix	153
34933T-001 Terminal Block for Two-Wire Mode	157
34933T-002 Terminal Block for One-Wire Mode	161



Matrix Switch Modules

The matrix switch modules for the 34980A offer a convenient way for you to connect multiple instruments to multiple points on your DUT. For a lower cost and better specification alternative, you can connect both matrix and multiplexer (MUX) modules.

Although flexible, it is possible to connect more than one source at the same time with a matrix. Make sure that dangerous or unwanted conditions are not created by these connections.

The family of matrix switch modules consists of:

- the 34931A with two (dual) matrices of latching armature switches. Each matrix is organized in a 4-row by 8-column configuration.
- the 34932A with two (dual) matrices of latching armature switches. Each matrix is organized in a 4-row by 16-column configuration.
- the 34933A, with non-latching reed switches, which you can configure for:
 - differential (2-wire) mode, which has two (dual) matrices. Each matrix is organized in a 4-row by 8-column configuration.
 - single-ended (1-wire) mode, which has four (quad) matrices. Each matrix is organized in a 4-row by 8-column configuration.

NOTE

Safety Interlock Analog Buses of the 34980A can carry 300 V signals. MUX and matrix modules with Analog Bus relays have a hardware Safety Interlock feature that forces Analog Bus relays open when their associated D-sub connector (faceplate) interlock pins lose continuity. This prevents signals from the Analog Buses from being present on D-sub connector pins. Optional Agilent terminal blocks automatically provide continuity for the interlock pins. When the terminal blocks are not used, you must provide continuity for the interlock pins in the DUT assembly. See pinout drawings and tables in this chapter for the location of interlock pins on the module of interest.

Matrix modules have Analog Bus relays on Bank 2 only, and thus, have interlock pins on only their Bank 2 connectors.

Normally, if you attempt to connect to the Analog Buses without a terminal block or cable connected, an error is generated. The `SYSTEM:ABUS:INTERlock:SIMulate` command allows you to temporarily disable errors generated by the Safety Interlock feature and enables the Safety Interlock simulation mode. Although Safety Interlock errors are suppressed in this mode, the actual Analog Bus relays affected by the Safety Interlock are disabled as long as no terminal block or cable is connected to the module.

SCPI Programming Examples for the Matrix Modules

The programming examples below provide you with SCPI command examples to use for actions specific to the matrix switch modules.

The slot and channel addressing scheme used in these examples follow the general form **sccc** where **s** is the mainframe slot number (1 through 8) and **ccc** is the three-digit channel number. Channel numbers for the matrix modules are derived as follows:

Two-wire mode: The channel numbers for the 34931A, 34932A, and the 34933A (2-wire mode) are derived from the crosspoint or intersection of rows and columns, columns having two digits. See the example below.

Displayed Channel	Means This...
5304	A 34931A, 34932A, 34933A (2-wire mode) matrix module is in slot 5, crosspoint is row 3, column 4. It might be easy to remember this channel configuration as "srcc" (slot, row, column, column)

One-wire mode: The channel numbers for the 34933A (in 1-wire mode) are derived from a specific matrix number and the crosspoint or intersection of rows and columns on that matrix. See the example below.

Displayed Channel	Means This...
2437	A 34933A matrix module in 1-wire mode is in slot 2, matrix of interest is 4, crosspoint is row 3, column 7. It might be easy to remember this channel configuration as "smrc" (slot, matrix, row, column)

For information on specific configurations, refer to the simplified schematics for the matrix modules. The schematics are in this chapter.

For complete information on the SCPI commands used to program the 34980A, refer to the Agilent 34980A Programmer's Reference contained on the 34980A Product Reference CD. For example programs, also refer to the 34980A Product Reference CD.

Opening and Closing Channels

Example: Closing and opening matrix channels (34931A, 34932A, and 34933A in two-wire mode) The following commands close and open channels 311 and 312 through 315 of a 34932A matrix module in 2-wire mode. This module is in slot 3. The channel number represents the matrix crosspoint of a row (one digit) and a column (two digits). For example, channel 311 represents crosspoint at row 3 and column 11 on a 34932A module.

```
ROUTE:CLOSE (@3311,3312:3315)
ROUTE:OPEN (@3311,3312:3315)
```

Example: Closing and opening matrix channels (34933A in one-wire mode) The following commands close and open channels 311 and 312 through 315 of the 34933A module in 1-wire mode. The module is in slot 4. The channel number represents the matrix and the matrix crosspoint of a row (one digit) and a column (one digit). For example, channel 311 represents the crosspoint on matrix 3 at row 1, column 1 on a 34933A module in 1-wire mode.

```
ROUTE:CLOSE (@3311,3312:3315)
ROUTE:OPEN (@3311,3312:3315)
```

NOTE

Although the previous two examples show the same channel numbers, the channels are derived differently as determined by a module's configuration mode. See [page 139](#) for channel number derivation.

Example: Closing and opening Analog Bus relays The following command connects the Analog Buses to Matrix 2 for a module (in 2-wire mode) in slot 3.

```
ROUTE:CLOSE (@3921,3922,3923,3924)
ROUTE:OPEN (@3921,3922,3923,3924)
```

NOTE

For matrix modules in 2-wire mode, only Matrix 2 connects to the Analog Buses. For the 34933A in 1-wire mode, only Matrix 3 and Matrix 4 connect to the Analog Buses.

The Analog Bus relays (numbered s921, s922, s923, etc.) on the matrix modules are ignored if they are included in a range of channels. An error will be generated if an Analog Bus relay is specified as the first or last channel in a range of channels. For example, the following command closes all valid channels between channel 304 and channel 615 (slot 2). In addition, this command closes Analog Bus relay 911 on the module in slot 1 (Bank 1). Note that although the specified range of channels includes the other Analog Bus relays, they are ignored and are not closed by this command.

```
ROUTE:CLOSE (@2304:2615,1911)
```

Example: Querying channels for open or close state The following command returns a 1 (true) or 0 (false) state of channel 204 for a module in slot 3.

```
ROUTe:CLOSE (@3204)
ROUTe:CLOSE? (@3204) !Returns a 1
ROUTe:OPEN? (@3204) !Returns a 0
```

Configuring a Module

Example: Configuring the 34933A module for 2-wire or 1-wire mode The following command configures a matrix module in slot 4 for 1-wire measurements. Because you can configure only the 34933A (and the 34923A and 34925A MUX modules) for either 2-wire or 1-wire mode, an error is generated if you send this command to a slot that does not contain one of those three modules. If you are using terminal blocks with the 34933A module, be sure to use the corresponding 2-wire or 1-wire terminal block.

```
SYSTem:MODUle:WIRE:MODE WIRE1,4
```

NOTE

When using a command to configure the system, the new configuration does not take effect until you cycle power on the 34980A.

Example: Querying the system for module identify The following command returns the identity of the module installed in slot 7.

```
SYSTem:CTYPe? 7
```

NOTE

For the 34933A matrix module, the query response may include a suffix to indicate a 1-wire configuration. For example, the response for the 34933A will be either "34933A" (differential mode) or "34933A-1W" (single-ended mode).

Reading Cycle Count and Resetting Modules to Power-On State

Example: Reading the cycle count for a relay The following command returns the cycle count on channels 304 and 308 for a matrix module in slot 3.

```
DIAGnostic:RELay:CYCLes? (@3304,3308)
```

Example: Resetting module(s) to power-on state The following command resets a module in slot 4 to its power-on state.

```
SYSTem:CPON 4
```

Linking Multiple Matrix Modules

You can link multiple matrix modules to form a larger matrix. The following two drawings show two-module connections through rows and columns.

Wiring Multiple 34931A or 34932A Modules

With a 34931A you can combine two matrices to form 8x8 (connecting columns) or 4x16 (connecting rows) configurations. Using two 34932A matrices on a 34932A module, you can create 16x8 (connecting columns) or 4x32 (connecting rows) configurations.

You can connect rows in separate modules using external wiring. Or, using Bank 2 matrices, you can connect through the mainframe Analog Buses. For a clear idea of how matrices are arranged and their connections to the Analog Buses, see the simplified schematics on [page 145](#) (34931A) and [page 150](#) (34932A).

You must use external wiring whenever you connect:

- Rows in Matrix 1 of separate modules
- Rows in Matrix 1 to rows in Matrix 2 on the same or separate modules
- Columns of two matrices on the same or separate modules

You can expand upon these two-module configurations and add up to eight modules to design your own large matrices. From a programming standpoint, each matrix module operates as an independent module regardless of the external connections. When linking modules, the channel numbering scheme remains the same as for single modules.

Wiring Multiple 34933A Modules

You can connect matrices on the 34933A module in a similar fashion to the 34931A. However, the presence of in-rush resistors on the Analog Buses and columns require additional consideration, and you must take care when linking multiple 34933A matrix modules. See the simplified schematics on [page 155](#) and [page 159](#).

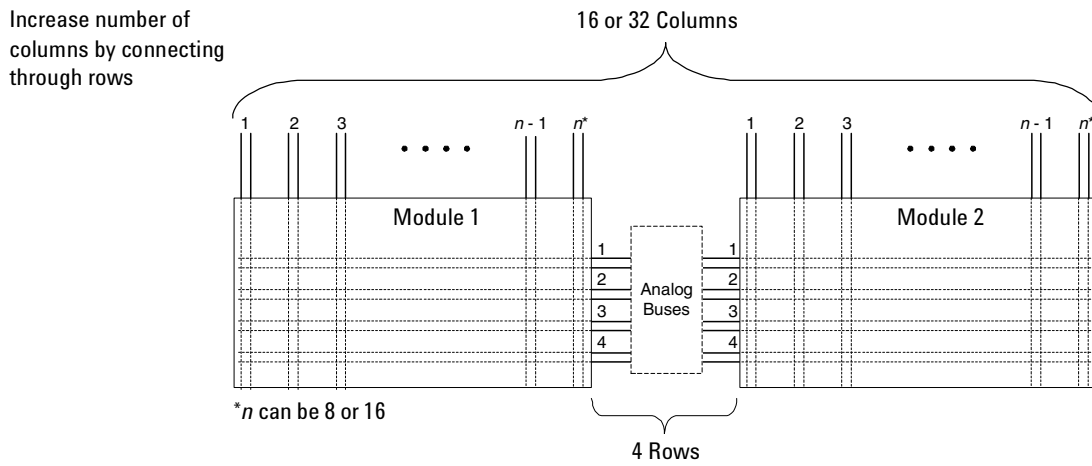
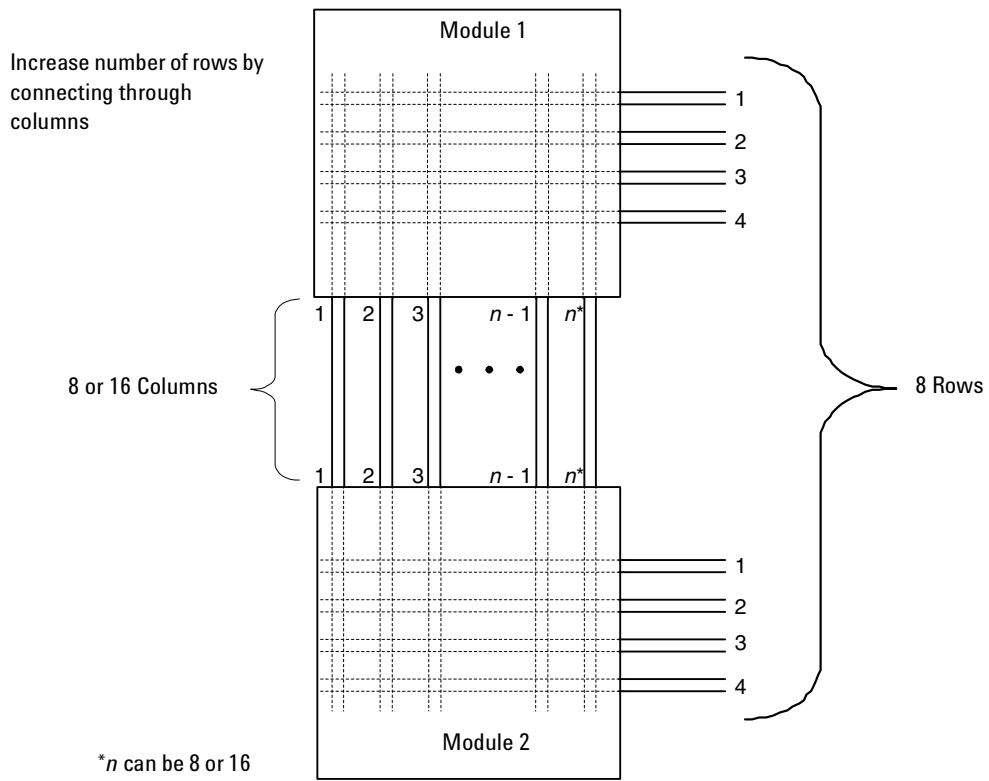

34931A Dual 4x8 Armature Matrix

The 34931A dual 4x8 armature matrix contains two matrices, each with 32 2-wire crosspoint latching armature relays organized in a 4- row by 8- column configuration. Every row and column are made up of two wires each, a high (H) and a low (L). Each crosspoint relay has a unique channel number representing the row and column that intersects to create the crosspoint. For example, channel 304 represent the crosspoint connection between row 3 and column 4 (all columns consisting of two digits; in this case the digits are 04). See the simplified schematic on [page 145](#).

You can connect any combination of inputs and outputs at the same time. However, only Matrix 2 in this module connects to the Analog Buses. By closing channels 921 and 922 you can connect rows 5 and 6 respectively to the internal DMM of the 34980A mainframe for voltage and resistance measurements. You can connect multiple matrix modules externally and/or through the Analog Buses for applications that require large matrices. For information on linking multiple matrices, refer to [page 142](#) of this chapter.

NOTE

When the DMM is scanning, it controls ABus1 and ABus2 relays, which are on Matrix 2. Therefore, consider this behavior when you are connecting matrices.

When the power is off, matrix relays maintain state, and Analog Bus relays open.

34931A Simplified Schematic

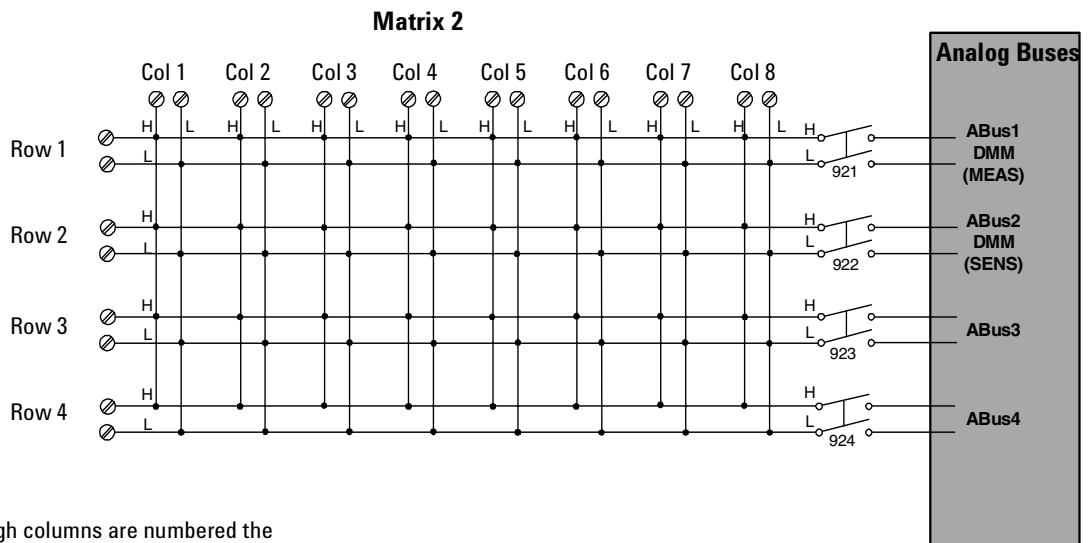
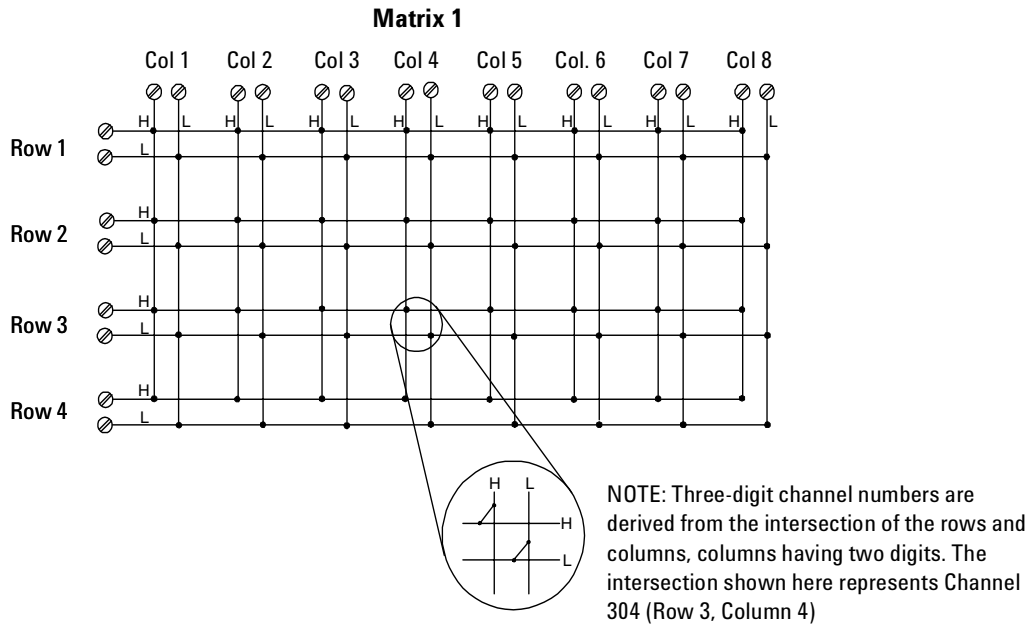

NOTE: Although columns are numbered the same on the two matrices, they are electrically separate.

NOTE:

Matrix relays: Armature latching

Analog Bus relays: Armature non-latching

34931A D-Sub Connectors

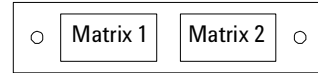

Matrix 1

For orientation, the D-sub connector end of the module is facing you.

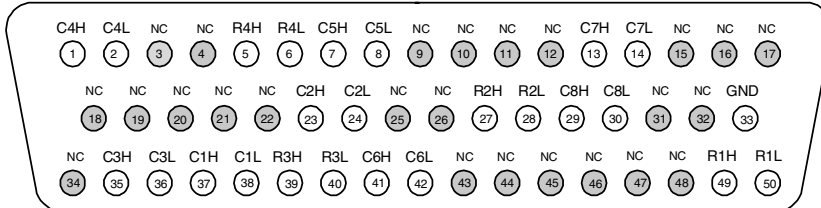

NOTE: In this diagram and the table below, R represents "row," and C represents "column."

Description	Pin	Description	Pin	Description	Pin
R1H	49	C2H	23	C7H	13
R1L	50	C2L	24	C7L	14
R2H	27	C3H	35	C8H	29
R2L	28	C3L	36	C8L	30
R3H	39	C4H	1	GND	33
R3L	40	C4L	2	No Connect pins: 3-4, 9-12, 15-22, 25-26, 31-32, 34, and 43-48.	
R4H	5	C5H	7		
R4L	6	C5L	8		
C1H	37	C6H	41		
C1L	38	C6L	42		

Matrix 2

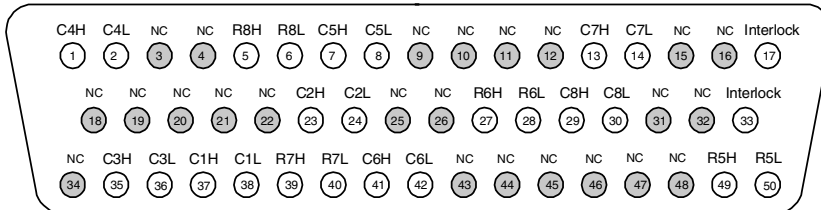

NOTE: In this diagram and the table below, R represents "row," and C represents "column."

WARNING As a safety feature, interlock pins (17 and 33) must be shorted to enable the Analog Bus relays, which are on Matrix 2, to close. The optional 34931T terminal block shorts these pins for you. This feature protects inadvertent routing of high voltages from the Analog Buses to the D-sub connector of the module.

Description	Pin	Description	Pin	Description	Pin
R5H	49	C2H	23	C7H	13
R5L	50	C2L	24	C7L	14
R6H	27	C3H	35	C8H	29
R6L	28	C3L	36	C8L	30
R7H	39	C4H	1	Interlock	17
R7L	40	C4L	2	Interlock	33
R8H	5	C5H	7	No Connect pins: 3-4, 9-12, 15-16. 18-22, 25-26, 31-32, 34, 43-48	
R8L	6	C5L	8		
C1H	37	C6H	41		
C1L	38	C6L	42		

34931T Terminal Block

This terminal block with screw-type connections is labeled with the model number and the abbreviated module name. In addition, space is available on the label for you to write the slot number.

NOTE

All modules that connect to the internal DMM are interlock protected. This means that when an installed module is exposed (no terminal block or cable is connected), the Analog Bus relays, which are on Matrix 2, are open and disconnected from the Analog Buses. See [page 138](#) for further information.

The 34980A Product Reference CD (shipped with the instrument) contains a the 34931T Wiring Log for you to document your wiring configuration for this module. You can open the wiring log file in Microsoft® Excel® or Adobe® Acrobat® format.

NOTE

On the 34931T terminal block, only two sets of screw terminals are for use with the 34931A module. See the following drawing.

When using the 34931T terminal block, be sure to wire your connections to the two sets of screw terminals closest to the 50-pin D-sub connectors.

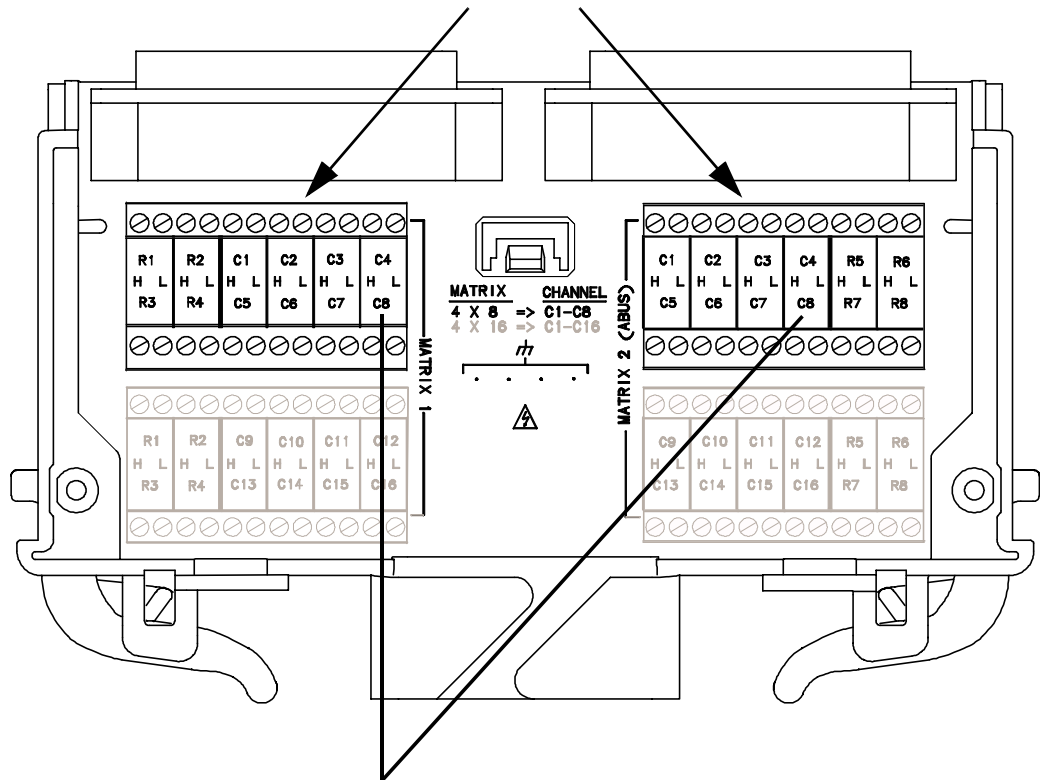

Although columns are numbered the same on the two matrices, they are electrically separate (example C8).

34932A Dual 4x16 Armature Matrix

The 34932A dual 4x16 armature matrix contains two matrices, each with 64 2-wire crosspoint latching armature relays organized in a 4-row by 16-column configuration. Every row and column are made up of two wires each, a high (H) and a low (L). Each crosspoint relay has a unique channel number representing the row and column that intersect to create the crosspoint. For example, channel 315 represents the crosspoint connection between row 3 and column 15 (all columns consisting of two digits; in this case the digits are 15). See the simplified schematic on [page 150](#).

You can connect any combination of inputs and outputs at the same time. However, only Matrix 2 in this module connects to the Analog Buses. By closing channels 921 and 922 you can connect rows 5 and 6 respectively to the internal DMM of the 34980A mainframe for voltage and resistance measurements. You can connect multiple matrix modules externally and/or through the Analog Buses for applications that require large matrices. For information on linking multiple matrix modules, refer to [page 142](#) of this chapter.

NOTE

When the DMM is scanning, it controls ABus1 and ABus2 relays, which are on Matrix 2. Therefore, consider this behavior when you are connecting matrices.

When the power is off, matrix relays maintain state, and Analog Bus relays open.

34932A Simplified Schematic

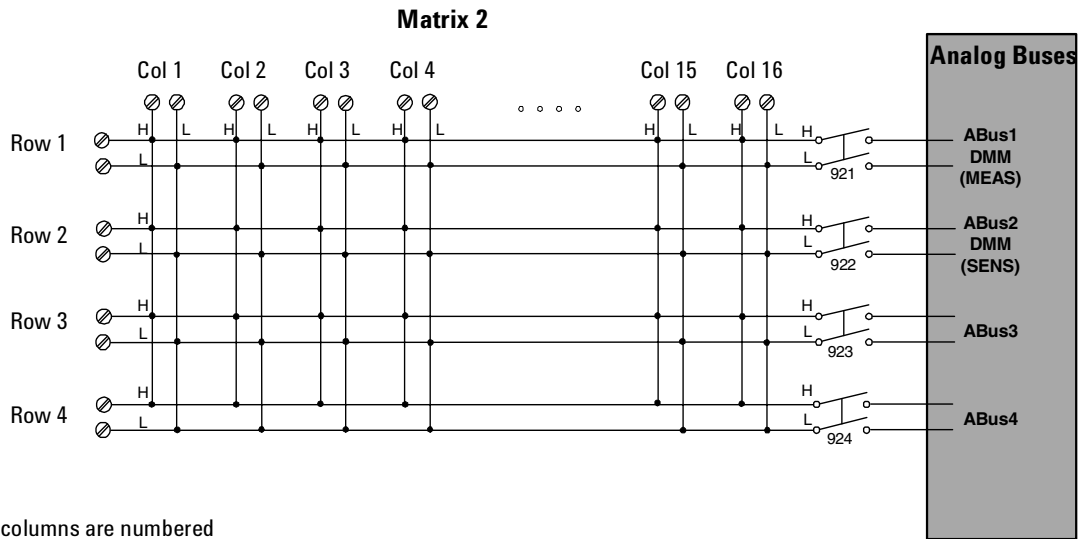
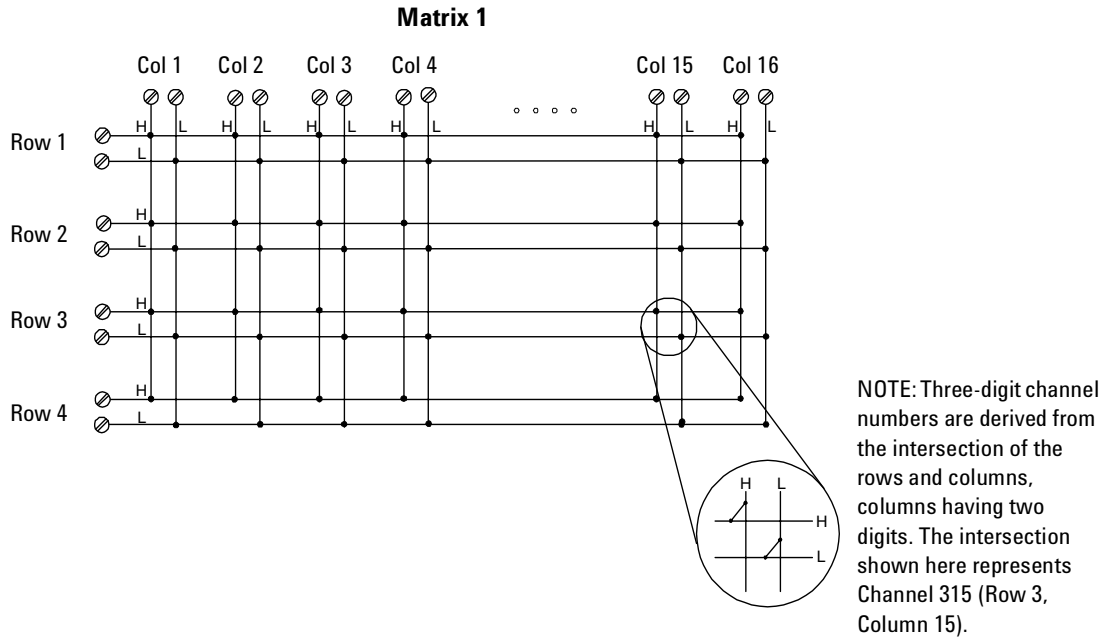

NOTE: Although columns are numbered the same on the two matrices, they are electrically separate.

NOTE:
 Matrix relays: Armature latching
 Analog Bus relays: Armature non-latching

34932A D-Sub Connectors

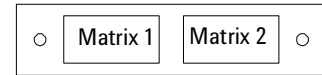

Matrix 1

For orientation, the D-sub connector end of the module is facing you.

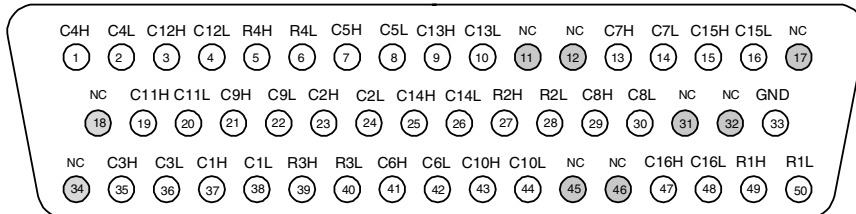

NOTE: In this diagram and the table below, R represents "row," and C represents "column."

Description	Pin	Description	Pin	Description	Pin	Description	Pin	Description	Pin
R1H	49	C2H	23	C7H	13	C12H	3	GND	33
R1L	50	C2L	24	C7L	14	C12L	4	No Connect pins: 11-12, 17-18, 31-32, 34, and 45-46	
R2H	27	C3H	35	C8H	29	C13H	9		
R2L	28	C3L	36	C8L	30	C13L	10		
R3H	39	C4H	1	C9H	21	C14H	25		
R3L	40	C4L	2	C9L	22	C14L	26		
R4H	5	C5H	7	C10H	43	C15H	15		
R4L	6	C5L	8	C10L	44	C15L	16		
C1H	37	C6H	41	C11H	19	C16H	47		
C1L	38	C6L	42	C11L	20	C16L	48		

Matrix 2

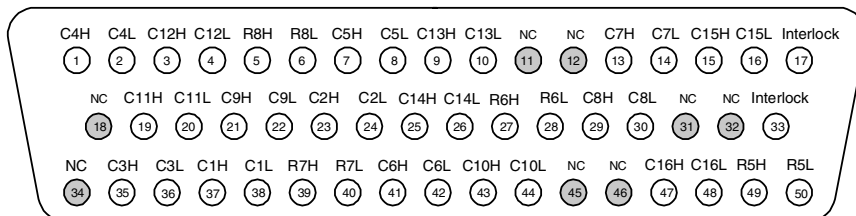

NOTE: In this diagram and the table below, R represents "row," and C represents "column."

WARNING As a safety feature, interlock pins (17 and 33) must be shorted to enable the Analog Bus relays, which are on Matrix 2, to close. The optional 34932T terminal block shorts these pins for you. This feature protects inadvertent routing of high voltages from the Analog Buses to the D-sub connector of the module.

Description	Pin	Description	Pin	Description	Pin	Description	Pin	Description	Pin
R5H	49	C2H	23	C7H	13	C12H	3	Interlock	17
R5L	50	C2L	24	C7L	14	C12L	4	Interlock	33
R6H	27	C3H	35	C8H	29	C13H	9	No connect pins: 11-12, 18, 31-32, 34, and 45-46.	
R6L	28	C3L	36	C8L	30	C13L	10		
R7H	39	C4H	1	C9H	21	C14H	25		
R7L	40	C4L	2	C9L	22	C14L	26		
R8H	5	C5H	7	C10H	43	C15H	15		
R8L	6	C5L	8	C10L	44	C15L	16		
C1H	37	C6H	41	C11H	19	C16H	47		
C1L	38	C6L	42	C11L	20	C16L	48		

34932T Terminal Block

This terminal block with screw-type connections is labeled with the model number and the abbreviated module name. In addition, space is available on the label for you to write the slot number.

NOTE All modules that connect to the internal DMM are interlock protected. This means that when an installed module is exposed (no terminal block or cable is connected), the Analog Bus relays, which are on Matrix 2, are open and disconnected from the Analog Buses. See [page 138](#) for further information.

The 34980A Product Reference CD (shipped with the instrument) contains a the 34932T Wiring Log for you to document your wiring configuration for this module. You can open the wiring log file in Microsoft® Excel® or Adobe® Acrobat® format

Although they have separate screw-type connectors, rows labeled the same on a matrix are electrically connected. Therefore, you can wire the same-matrix rows in two locations.

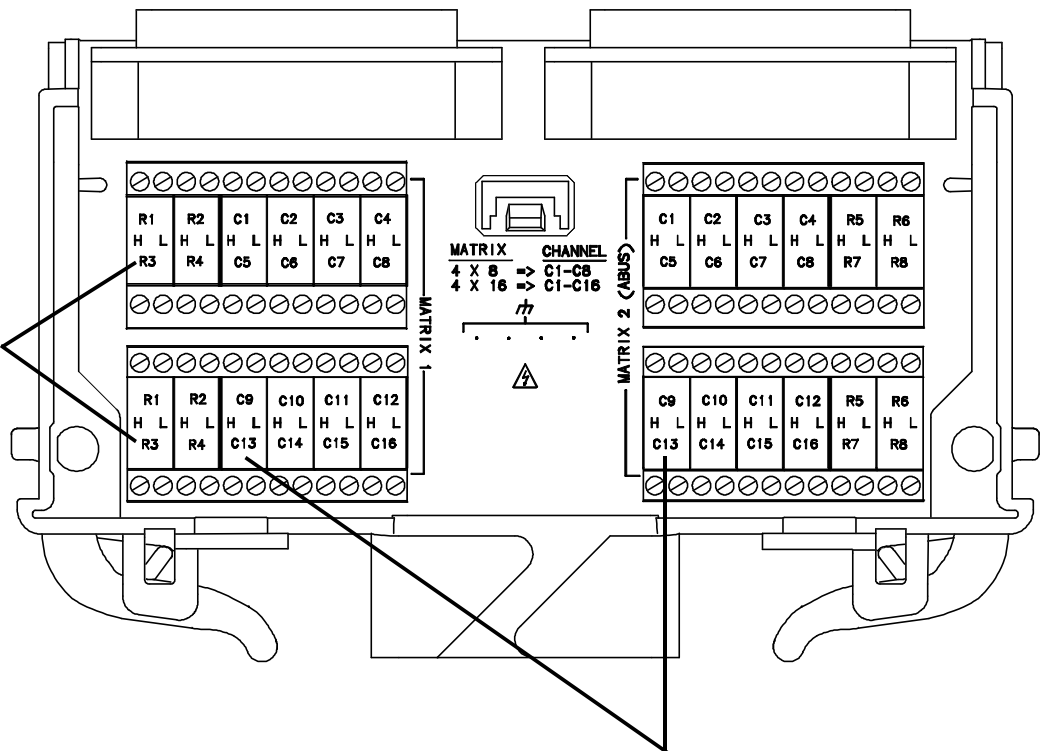

Although columns are numbered the same on the two matrices, they are electrically separate. (example, C13)

34933A Dual/Quad 4x8 Reed Matrix

Using program commands or the front panel of the 34980A, you can configure the 34933A dual/quad 4x8 reed matrix module for differential (2-wire) mode or single-ended (1-wire) mode.

The 34933A module contains 100 Ω in-rush resistors that are used to protect the reed relays from reactive loads. If you have applications where in-rush resistors interfere with measurements, connections are provided on the terminal blocks for you to bypass the in-rush resistors that are located on the columns. See the simplified schematics on [page 155](#) and [page 159](#). However, if you choose to bypass the in-rush resistors, the life of the reed relays that you bypass may be degraded.

Two-Wire Mode

To physically configure the module for 2-wire mode, use the 34933T-001 terminal block, or a compatible standard or custom cable. If using a standard or custom cable, make sure you connect interlock pins 17 and 33 on the Matrix 2 D-sub connector. Refer to the pinout drawing and table on [page 156](#).

In 2-wire mode, the 34933A module contains two matrices, each with 32 2-wire crosspoint non-latching reed relays organized in a 4-row by 8-column configuration. Every row and column are made up of two wires each, a high (H) and a low (L). Each crosspoint relay has a unique channel number representing the row and column that intersect to create the crosspoint. For example, channel 308 represents the crosspoint connection between row 3 and column 08 (all columns consisting of two digits; in this case the digits are 08). See the simplified schematic on [page 155](#).

You can connect any combination of inputs and outputs at the same time. However, only Matrix 2 in 2-wire mode of this module connects to the Analog Buses. By closing channels 921 and 922 you can connect rows 5 and 6 respectively to the internal DMM of the 34980A mainframe for voltage and resistance measurements.

In 2-wire mode, you can close no more than 20 channels simultaneously due to power dissipation. However, note that Analog Bus relays count half as much as channel relays in that total. For example, with one Analog Bus relay closed, you can close up to a maximum of 19 channel relays. If you try to close more than the allowed number of channels, you will receive an error message.

One-Wire Mode

To physically configure the module in 1-wire mode, use the 34933T-002 terminal block, or a compatible standard or custom cable. If using a standard or custom cable, make sure you connect interlock pins 17 and 33 on the Matrix 2 D-sub connector. Refer to the pinout drawing and table on [page 160](#).

In 1-wire mode, the 34933A module contains four matrices (1 through 4), each with 32 1-wire crosspoint non-latching reed relays organized in a 4-row by 8-column configuration. Every row and column has one wire each. Each crosspoint relay has a unique channel number representing the matrix, and the single-wire row and column that intersect to make the crosspoint. For example, channel 218 represents Matrix 2, row 1 and column 8. See the simplified schematic on [page 159](#).

In 1-wire mode, you can close no more than 40 channels simultaneously due to power dissipation. For example, with one Analog Bus relay closed you can close up to a maximum of 39 channel relays. If you try to close more than the allowed number of channels, you will receive an error message.

You can connect any combination of inputs and outputs at the same time. However, only Matrix 3 and Matrix 4 in 1-wire mode of this module connect to the Analog Buses. By closing channels 921 and 922 you can connect rows 1 and rows 2 respectively to the internal DMM of the 34980A mainframe for voltage and resistance measurements.

You can connect multiple matrix modules externally and/or through the Analog Buses for applications that require large matrices. For information on linking multiple matrix modules, refer to [page 142](#) of this chapter.

When the power is off, matrix relays and Analog Bus relays open.

34933A Simplified Schematic for Two-Wire Mode

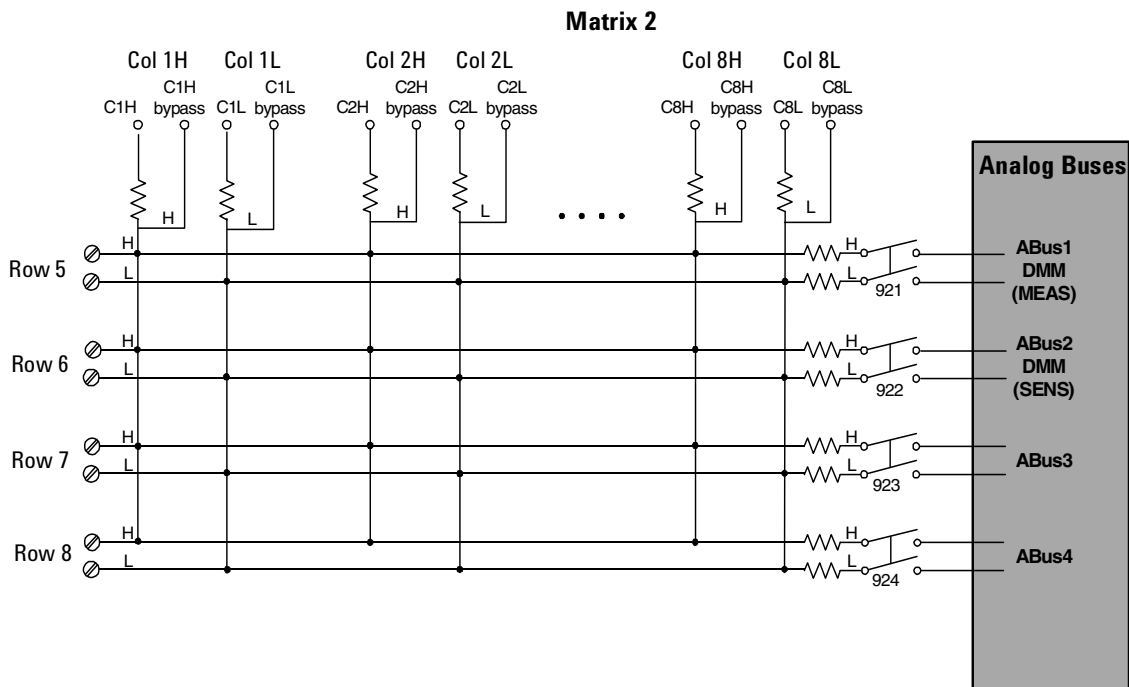
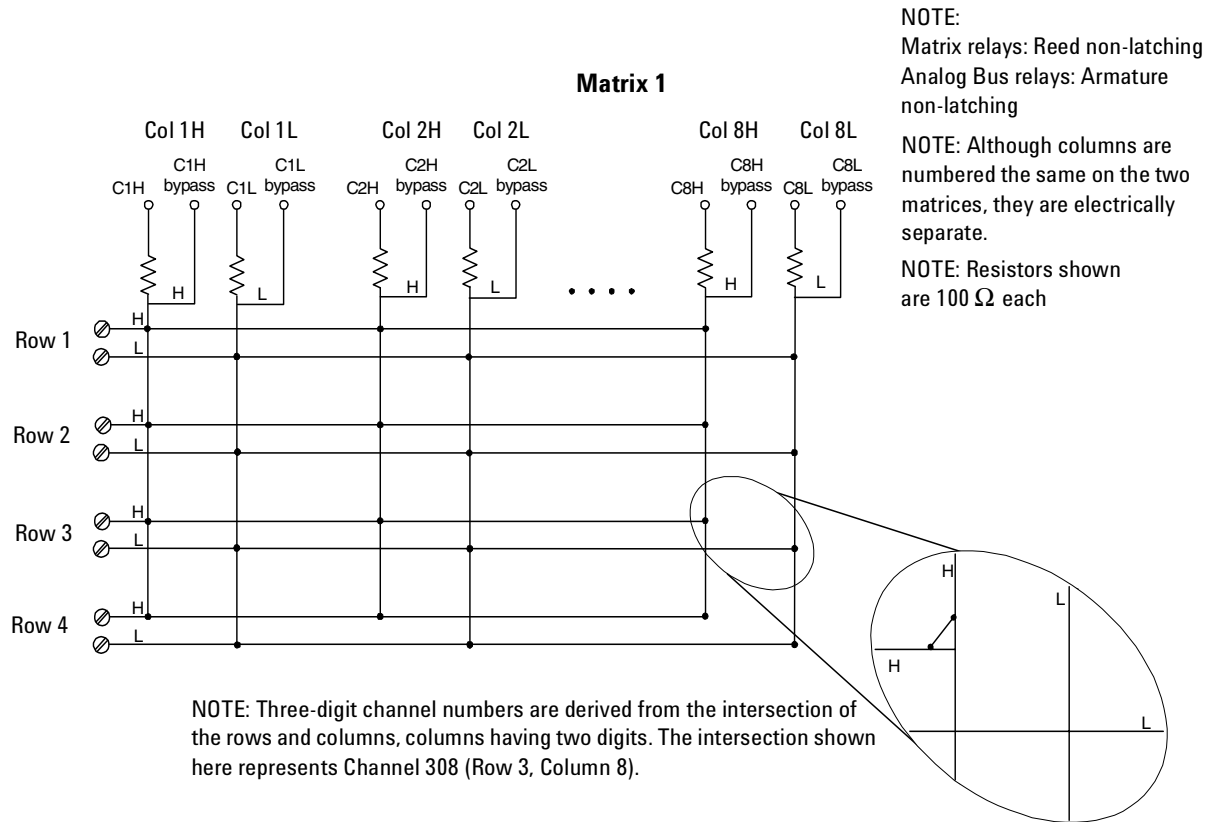

34933A D-Sub Connectors for Two-Wire Mode

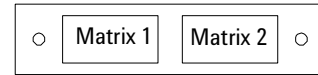

Matrix 1

For orientation, the D-sub connector end of the module is facing you.

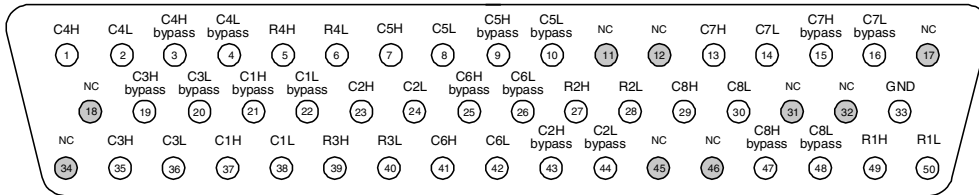

NOTE:

- In this diagram and the table below, R represents “row,” and C represents “column.”
- Bypass” means to bypass the 100Ω in-rush resistor that protects the reed relays.

Description	Pin	Description	Pin	Description	Pin	Description	Pin	Description	Pin	Description	Pin
R1H	49	C1H	37	C5H	7	C1H bypass	21	C5H bypass	9	GND	33
R1L	50	C1L	38	C5L	8	C1L bypass	22	C5L bypass	10	No Connect pins: 11-12, 17-18, 31-32, 34, and 45-46	
R2H	27	C2H	23	C6H	41	C2H bypass	43	C6H bypass	25		
R2L	28	C2L	24	C6L	42	C2L bypass	44	C6L bypass	26		
R3H	39	C3H	35	C7H	13	C3H bypass	19	C7H bypass	15		
R3L	40	C3L	36	C7L	14	C3L bypass	20	C7L bypass	16		
R4H	5	C4H	1	C8H	29	C4H bypass	3	C8H bypass	47		
R4L	6	C4L	2	C8L	30	C4L bypass	4	C8L bypass	48		

Matrix 2

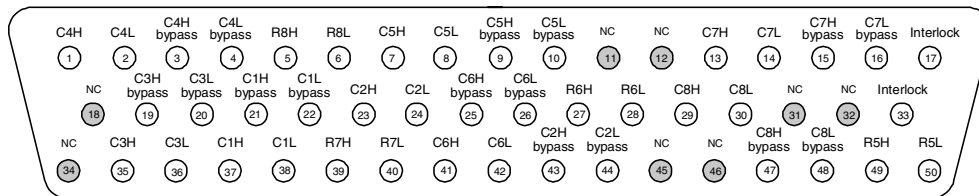

NOTE:

- In this diagram and the table below, R represents “row,” and C represents “column.”
- “Bypass” means to bypass the 100Ω in-rush resistor that protects the reed relays.

WARNING As a safety feature, interlock pins (17 and 33) must be shorted to enable the Analog Bus relays, which are on Matrix 2, to close. The optional 34933T-001 (for 2-wire) terminal block shorts these pins for you. This feature protects inadvertent routing of high voltages from the Analog Bus to the D-sub connector of the module.

Description	Pin	Description	Pin	Description	Pin	Description	Pin	Description	Pin
R5H	49	C2H	23	C7H	13	C4H bypass	3	Interlock	17
R5L	50	C2L	24	C7L	14	C4L bypass	4	Interlock	33
R6H	27	C3H	35	C8H	29	C5H bypass	9	No Connect pins: 11-12, 18, 31-32, 34, and 45-46	
R6L	28	C3L	36	C8L	30	C5L bypass	10		
R7H	39	C4H	1	C1H bypass	21	C6H bypass	25		
R7L	40	C4L	2	C1L bypass	22	C6L bypass	26		
R8H	5	C5H	7	C2H bypass	43	C7H bypass	15		
R8L	6	C5L	8	C2L bypass	44	C7L bypass	16		
C1H	37	C6H	41	C3H bypass	19	C8H bypass	47		
C1L	38	C6L	42	C3L bypass	20	C8L bypass	48		

34933T-001 Terminal Block for Two-Wire Mode

This terminal block with screw-type connections is labeled with the model number and the abbreviated module name. In addition, space is available on the label for you to write the slot number.

NOTE

All modules that connect to the internal DMM are interlock protected. This means that when an installed module is exposed (no terminal block or cable is connected), the Analog Bus relays, which are on Matrix 2, are open and disconnected from the Analog Buses. See [page 138](#) for further information.

The 34980A Product Reference CD (shipped with the instrument) contains a the 34933T (2-wire) Wiring Log for you to document your wiring configuration for this module. You can open the wiring log file in Microsoft® Excel® or Adobe® Acrobat® format

NOTE

If you are using an Agilent terminal block to connect your DUT to this module be sure to use the 34933T-001 terminal block that corresponds to the 2-wire configuration mode. Note that an error will not be generated if you have installed a terminal block that doesn't match the present module configuration.

Although columns are numbered the same on the two matrices, they are electrically separate.

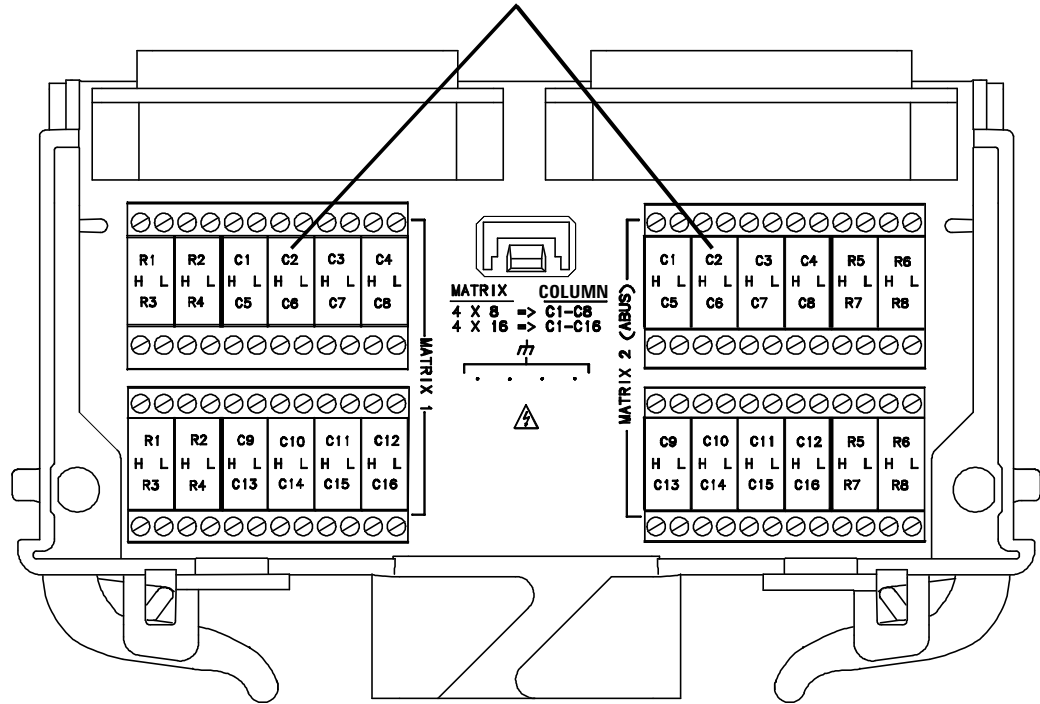

When using the 34933T terminal block for 2-wire mode, access is provided to the bypass columns through the columns labeled C9 through C16. Follow this wiring convention shown in the table below for both matrices.

Terminal marked...	Connects to...	Terminal marked...	Connects to...
C9H	C1Hbypass	C13H	C5H bypass
C9L	C1L bypass	C13L	C5L bypass
C10H	C2H bypass	C14H	C6H bypass
C10L	C2L bypass	C14L	C6L bypass
C11H	C3H bypass	C15H	C7H bypass
C11L	C3L bypass	C15L	CC7L bypass
C12H	C4H bypass	C16H	C8H bypass
C12L	C4L bypass	C16L	C8L bypass

34933A Simplified Schematic for One-Wire Mode

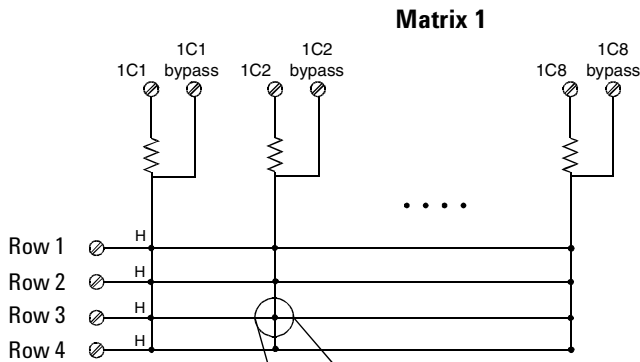

NOTE: Three-digit channel numbers are derived from a specific matrix number and the intersection of rows and columns on that matrix. The channel shown here is 132 (Matrix 1, Row 3, Column 2.)

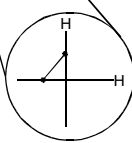

NOTE: Although rows are numbered the same across the matrices, they are electrically separate.

NOTE:
Matrix relays: Reed non-latching
Analog Bus relays: Armature non-latching

NOTE: Resistors shown are 100 Ω each

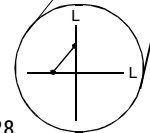
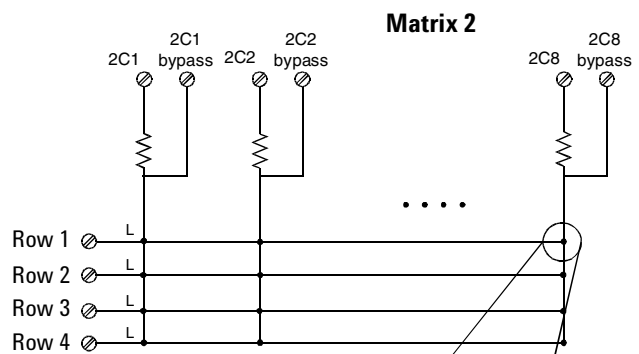

Channel 2128
(Matrix 2, Row 1, Column 8)

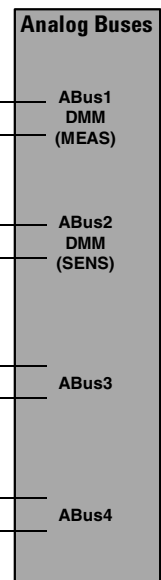
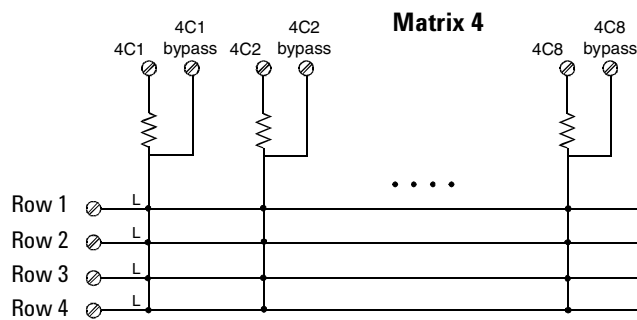
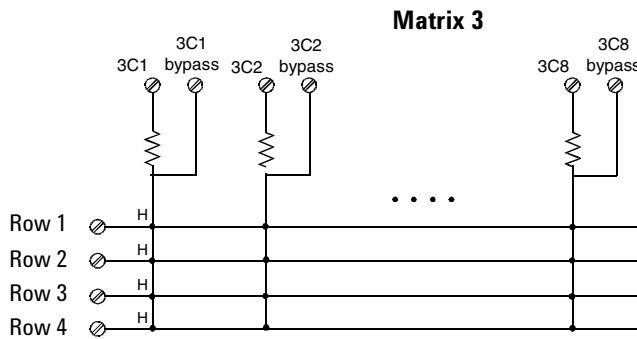

34933A D-Sub Connectors for One-Wire Mode

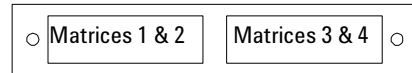

Matrices 1 and 2

For orientation, the D-sub connector end of the module is facing you.

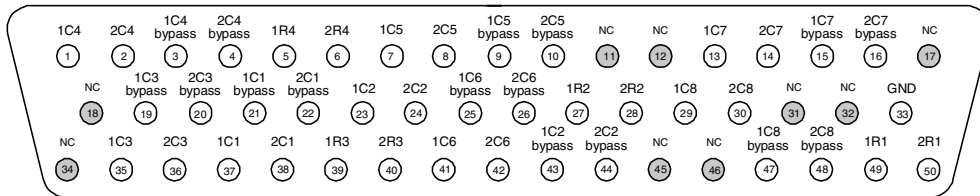

NOTE: Conventions for these drawings and tables as they relate to pinout information:

- **2R4** means Matrix **2**, Row **4**.
- **1C5** means Matrix **1**, Column **5**
- **4C2 bypass** means: Matrix **4**, Column **2**, and the connection bypasses the 100Ω in-rush resistor that protects the reed relays

Description	Pin	Description	Pin	Description	Pin	Description	Pin	Description	Pin
1R1	49	1C2	23	1C7	13	1C4 bypass	3	GND	33
1R2	27	2C2	24	2C7	14	2C4 bypass	4	No connect pins: 11-12, 17-18, 31-32, 34, and 45-46	
1R3	39	1C3	35	1C8	29	1C5 bypass	9		
1R4	5	2C3	36	2C8	30	2C5 bypass	10		
2R1	50	1C4	1	1C1 bypass	21	1C6 bypass	25		
2R2	28	2C4	2	2C1 bypass	22	2C6 bypass	26		
2R3	40	1C5	7	1C2 bypass	43	1C7 bypass	15		
2R4	6	2C5	8	2C2 bypass	44	2C7 bypass	16		
1C1	37	1C6	41	1C3 bypass	19	1C8 bypass	47		
2C1	38	2C6	42	2C3 bypass	20	2C8 bypass	48		

Matrices 3 and 4

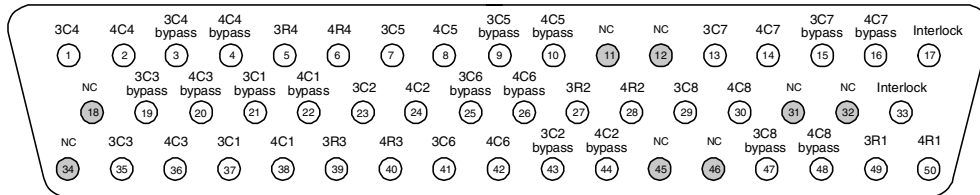

WARNING As a safety feature, interlock pins (17 and 33) must be shorted to enable the Analog Bus relays, which are on Matrix 2, to close. The optional 34933T-002 (for 1-wire) terminal block shorts these pins for you. This safety feature protects inadvertent routing of high voltages from the Analog Buses to the D-sub connector of the module.

Description	Pin	Description	Pin	Description	Pin	Description	Pin	Description	Pin
3R1	49	3C2	23	3C7	13	3C4 bypass	3	Interlock	17
3R2	27	4C2	24	4C7	14	4C4 bypass	4	Interlock	33
3R3	39	3C3	35	3C8	29	3C5 bypass	9	No connect pins: 11-12, 18, 31-32, 34, and 45-46	
3R4	5	4C3	36	4C8	30	4C5 bypass	10		
4R1	50	3C4	1	3C1 bypass	21	3C6 bypass	25		
4R2	28	4C4	2	4C1 bypass	22	4C6 bypass	26		
4R3	40	3C5	7	3C2 bypass	43	3C7 bypass	15		
4R4	6	4C5	8	4C2 bypass	44	4C7 bypass	16		
3C1	37	3C6	41	3C3 bypass	19	3C8 bypass	47		
4C1	38	4C6	42	4C3 bypass	20	4C8 bypass	48		

34933T-002 Terminal Block for One-Wire Mode

This terminal block with screw-type connections is labeled with the model number and the abbreviated module name. In addition, space is available on the label for you to write the slot number.

NOTE

All modules that connect to the internal DMM are interlock protected. This means that when an installed module is exposed (no terminal block or cable is connected), the Analog Bus relays and current channels are open and disconnected from the Analog Buses. See [page 138](#) for further information.

The 34980A Product Reference CD (shipped with the instrument) contains a the 34933T (1-wire) Wiring Log for you to document your wiring configuration for this module. You can open the wiring log file in Microsoft® Excel® or Adobe® Acrobat® format

NOTE

If you are using an Agilent terminal block to connect your DUT to this module be sure to use the 34933T-002 terminal block that corresponds to the 1-wire configuration mode. Note that an error will not be generated if you have installed a terminal block that doesn't match the present module configuration.

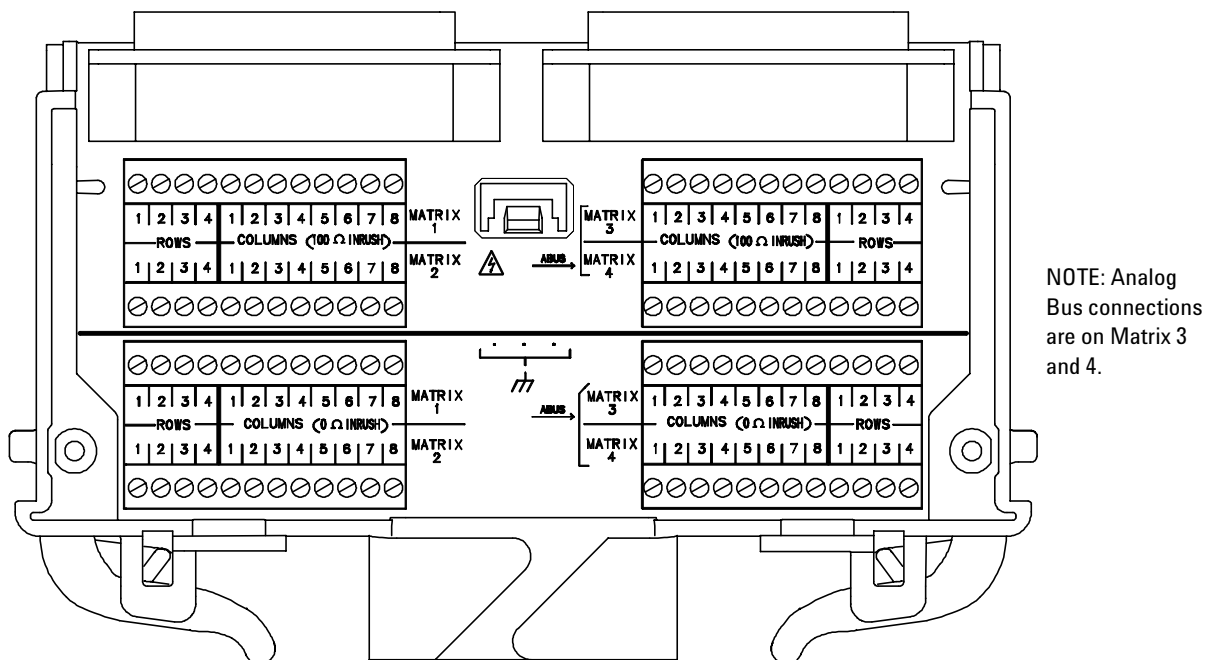

5 Matrix Switch Modules

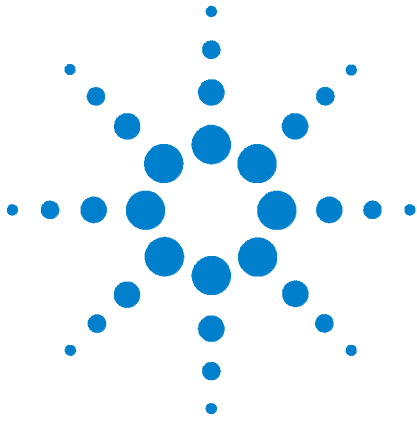

6 General Purpose Switch Modules

General Purpose Switch Modules	164
34937A and 34938A SCPI Programming Examples	166
34937A 32-Channel GP Switch	168
34937T Terminal Block	170
34938A 20-Channel High-Current GP Switch	171
34938T Terminal Block	173



General Purpose Switch Modules

Use the general-purpose (GP) switch modules in your 34980A mainframe to route signals or control other system devices.

- The 34937A 32-Channel Form C and Form A GP Switch Module provides independent control of 32 latching relays:
 - Twenty-eight Form C relays rated for 1 A at 60 W per channel
 - Four Form A relays rated for 5 A at 150 W per channel.
- For power switching applications, the 34938A 21-Channel 5 A Form A Switch Module offers 20 Form A relays rated for 5 A at 150 W per channel.

Both modules contain armature-latching relays, and you can use these switches for device actuation, digital output, or combined with other switch modules to create flexible switching topologies. You can close multiple channels at the same time. These modules do not connect to the analog buses.

A temperature sensor on these modules triggers system interrupts when high-current-induced heat on the modules is excessive and sets the HOT annunciator on the front panel. This over-temperature situation generates an SRQ event when the factory-set 70 °C threshold is reached. It is up to the user to determine what, if any, action should be taken.

Reactive loads (those that include significant inductance or capacitance) can cause voltage spikes or current spikes during switching operations. The general purpose modules are designed for switching reactive loads. The optional 34937T and 34938T terminal blocks have solder pads for adding snubber circuits for the 5 A relays to reduce the reactive transients. See the drawings on [page 170](#) and [page 173](#) for the locations of snubber circuit pads and installation information about a snubber circuit.

A hardware jumper on each of the GP modules allows you to define the power-failure states for the modules' 5 A latching relays. Depending on the position of the jumper, the 5 A relays will either open or maintain state when system power failure occurs. When shipped from the factory, the power-fail jumper is in "MAINTAIN" position (all relays maintain their present state when power fails).

NOTE

The 34937A has five 5 A relays, and the 34938A modules has 20 5 A relays

WARNING

Before changing the position of the jumper, remove external connections from the module. Wait five to ten seconds to allow the module's internal capacitors to discharge.

After a five- to ten-second delay, remove the sheet metal cover from the module and move the position of the jumper mounted on the module. See the next drawing for the jumper's location on the module.

WARNING Do not connect either the 34937A or 34938A module directly to a mains power outlet. If it is necessary to measure a mains voltage or any circuit where a large inductive load may be switched, you must add signal conditioning elements to reduce the potential transients before they reach the module or the Analog Buses.

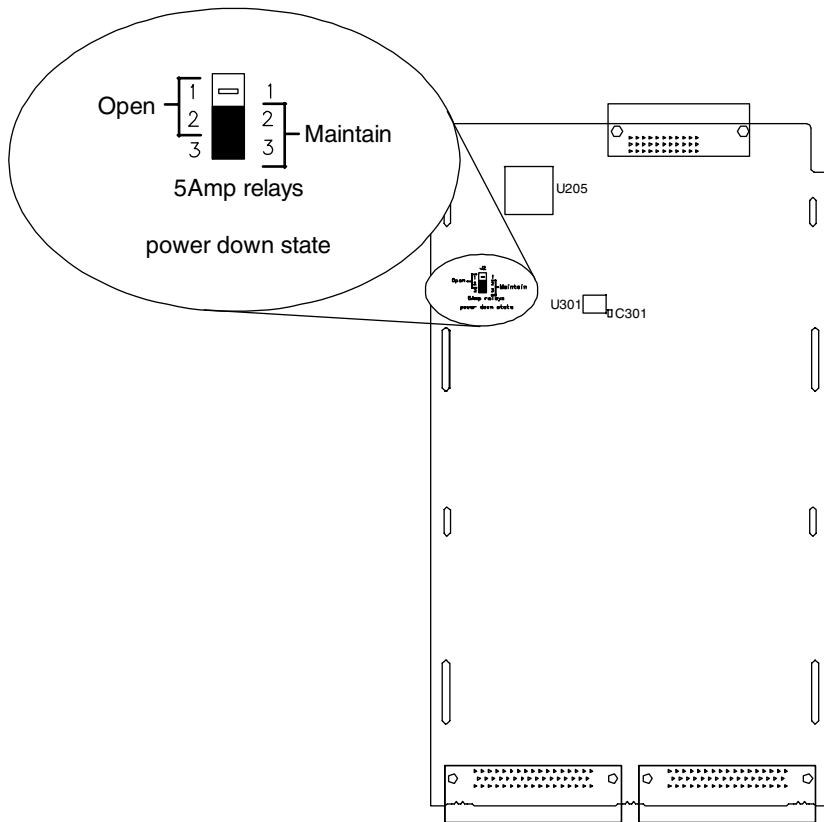

34937A and 34938A SCPI Programming Examples

The programming examples below provide you with SCPI command examples to use for actions specific to the general purpose switch modules.

The slot and channel addressing scheme used in these examples follow the form **sccc** where **s** is the mainframe slot number (1 through 8) and **ccc** is the channel number.

For complete information on the SCPI commands used to program the 34980A, refer to the Agilent 34980A Programmer's Reference contained on the 34980A Product Reference CD. For example programs, also refer to the 34980A Product Reference CD.

Opening and Closing Channels

Example: Closing and opening channels The first two commands close channel 3 for a module in slot 2, then channel 5 for that module. The last command opens both channel 3 and channel 5.

```
ROUTE:CLOSE (@2003)
ROUTE:CLOSE (@2005)
ROUTE:OPEN (@2003,2005)
```

Example: Querying channels for open or close state The following command returns a 1 (true) or 0 (false) state of channel 016 for a module in slot 3.

```
ROUTE:CLOSE (@3016)
ROUTE:CLOSE? (@3016) !Returns a 1
ROUTE:OPEN? (@3016) !Returns a 0
```

Reading Jumper State and System Identity

Example: Querying the power-failure state of 5 A relays The following command returns the position of the power-fail jumper, either "MAIN" (all relays maintain their present state when power fails) or "OPEN" (all relays open when power fails) for a module in slot 4. If this command is sent to a module other than the 34937A or 34938A, "NONE" is returned (no error is generated).

```
SYSTEM:MODULE:PFAil:JUMPer:AMP5? 4
```

Example: Querying the system for module identify (all modules) The following command returns the identify of the module installed in slot 7.

```
SYSTEM:CTYPE? 7
```

Reading Cycle Count and Resetting Modules to Power-On State

Example: Reading the cycle count for a relay (all switch modules) The following command returns the relay cycle count on channel 7 and channel 16 for a module in slot 1.

```
DIAGnostic:RELay:CYCLes? (@1007,1016)
```

Example: Clearing the cycle count for a relay (all switch modules) The following command resets the relay cycle count on channels 7 and 16 for a module in slot 1.

```
DIAGnostic:RELay:CYCLes:CLear (@1007,1016)
```

Example: Resetting Module(s) to power-on state (all modules) The following command resets a module in slot 4 to its power-on state.

```
SYSTem:CPON 4
```

34937A 32-Channel GP Switch

The 34937A general-purpose switch module provides independent control of:

- Twenty-eight Form C (DPST) latching relays rated at 1 A
- Four Form A (SPST) latching relays rated at 5 A. You can set the power-failure state for these 5 A relays. See [page 164](#) and [page 165](#).

NOTE

A temperature sensor on these modules triggers system interrupts when high-carry current-induced heat on the modules reaches a threshold of 70 °C.

34937A Simplified Schematic

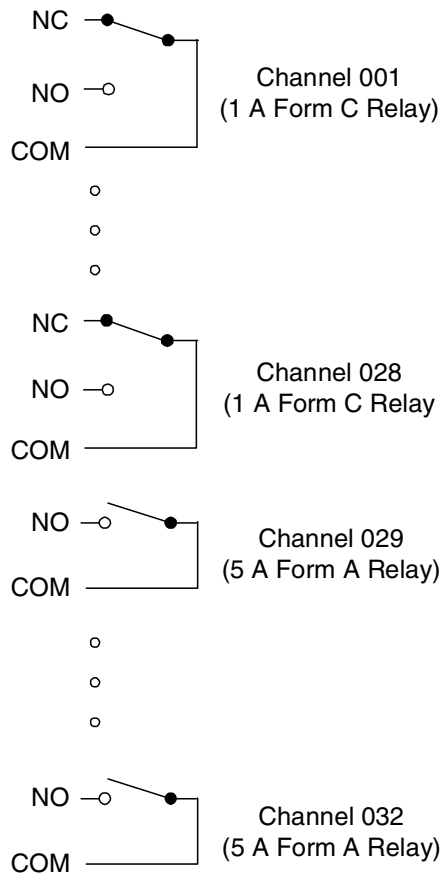

34937A D-Sub Connectors

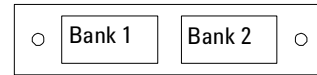

Bank 1

For orientation, the D-sub connector end of the module is facing you.

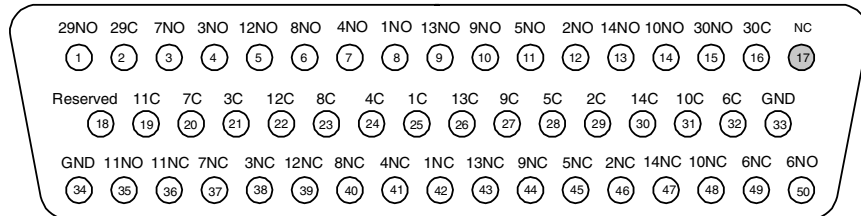

Channel	Pin	Channel	Pin	Channel	Pin	Channel	Pins	Channel	Pins		
1 NC	42	4 NC	41	7 NC	37	10 NC	48	13 NC	43	30 NO	15
1 Common	25	4 Common	24	7 Common	20	10 Common	31	13 Common	26	30 Common	16
1 NO	8	4 NO	7	7 NO	3	10 NO	14	13 NO	9	Reserved	18
2 NC	46	5 NC	45	8 NC	40	11 NC	36	14 NC	47	GND	33
2 Common	29	5 Common	28	8 Common	23	11 Common	19	14 Common	30	GND	34
2 NO	12	5 NO	11	8 NO	6	11 NO	35	14 NO	13	No Connect	17
3 NC	38	6 NC	49	9 NC	44	12 NC	39	29 NO	1		
3 Common	21	6 Common	32	9 Common	27	12 Common	22	29 Common	2		
3 NO	4	6 NO	50	9 NO	10	12 NO	5				

Bank 2

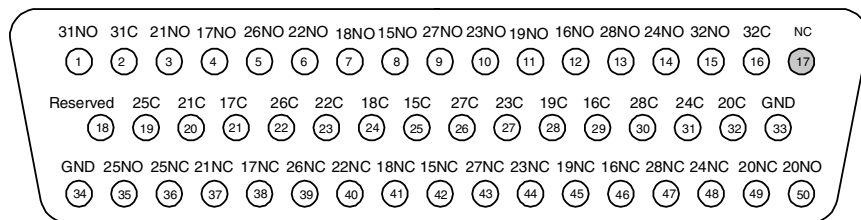

Channel	Pin	Channel	Pin	Channel	Pin	Channel	Pins	Channel	Pins		
15 NC	42	18 NC	41	21 NC	37	24 NC	48	27 NC	43	32 NO	15
15 Common	25	18 Common	24	21 Common	20	24 Common	31	27 Common	26	32 Common	16
15 NO	8	18 NO	7	21 NO	3	24 NO	14	27 NO	9	Reserved	18
16 NC	46	19 NC	45	22 NC	40	25 NC	36	28 NC	47	GND	33
16 Common	29	19 Common	28	22 Common	23	25 Common	19	28 Common	30	GND	34
16 NO	12	19 NO	11	22 NO	6	25 NO	35	28 NO	13	No Connect	17
17 NC	38	20 NC	49	23 NC	44	26 NC	39	31 NO	1		
17 Common	21	20 Common	32	23 Common	27	26 Common	22	31 Common	2		
17 NO	4	20 NO	50	23 NO	10	26 NO	5				

34937T Terminal Block

This terminal block with screw-type connections is labeled with the model number and the abbreviated module name. In addition, space is available on the label for you to write the slot number.

The 34980A Product Reference CD (shipped with the instrument) contains a the 34937T Wiring Log for you to document your wiring configuration for this module. You can open the wiring log file in Microsoft® Excel® or Adobe® Acrobat® format.

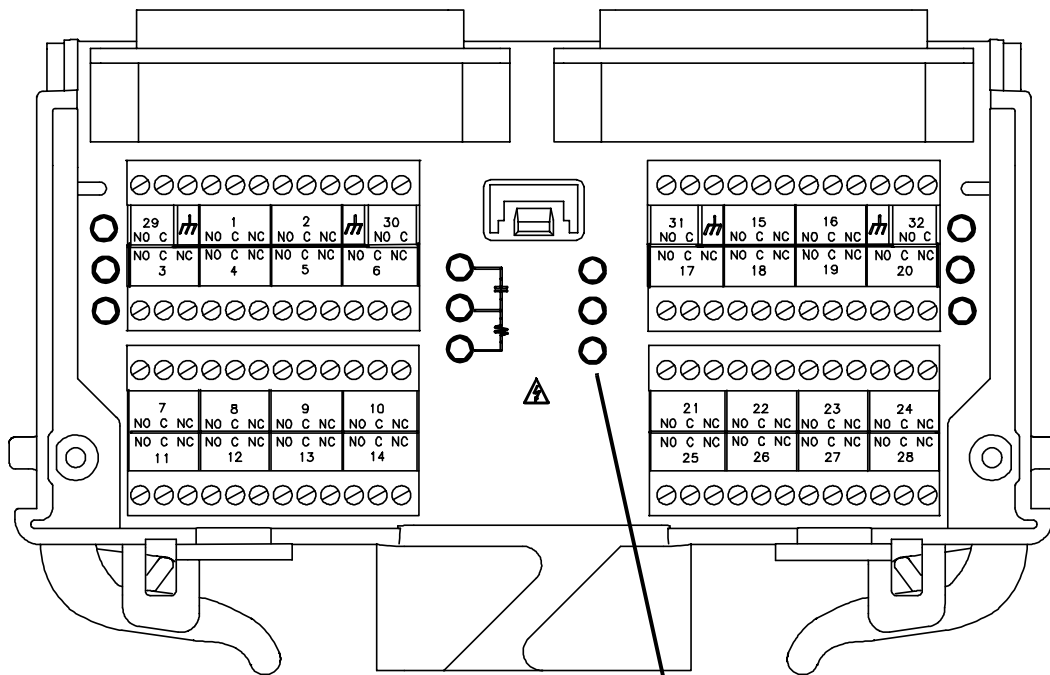

○ Pads for user-supplied snubber circuitry to alleviate reactive transients. The circuits may consist of resistors, capacitors, varistors, or other elements as needed to reduce the switching voltage and current transients inherent in reactive circuits.

34938A 20-Channel High-Current GP Switch

The 34938A high-channel GP switch module provides twenty 5 A Form A relays for general purpose switching needs. You can set the power-failure state for these 5 A relays. See [page 164](#) and [page 165](#).

NOTE

A temperature sensor on these modules triggers system interrupts when high-current-induced heat on the modules reaches a threshold of 70 °C.

34938A Simplified Schematic

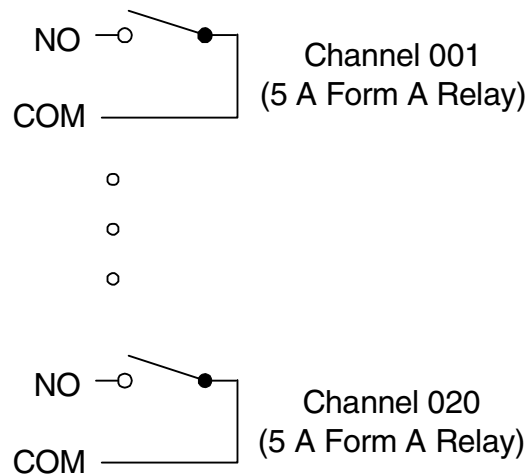

34938A D-Sub Connectors

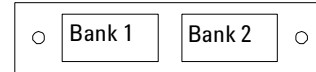

Bank 1

For orientation, the D-sub connector end of the module is facing you.

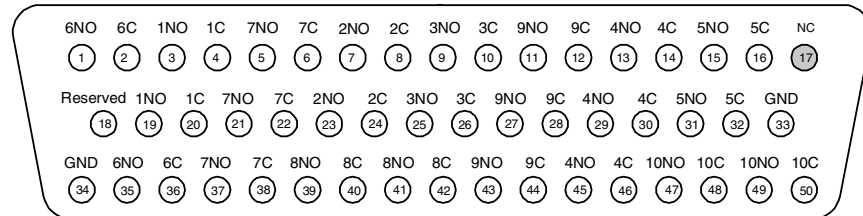

Channel	Pin	Channel	Pin	Channel	Pin	Channel	Pins	Channel	Pins
1NO	3	3NO	25	5NO	31	7NO	37	9NO	43
1Common	4	3Common	26	5Common	32	7Common	38	9Common	44
1NO	19	4NO	13	6NO	1	8NO	39	10NO	47
1Common	20	4Common	14	6Common	2	8Common	30	10Common	48
2NO	7	4NO	29	6NO	35	8NO	41	10NO	49
2Common	8	4Common	30	6Common	36	8Common	42	10Common	50
2NO	23	4NO	45	7NO	5	9NO	11	Reserved	18
2Common	24	4Common	46	7Common	6	9Common	12	GND	33
3NO	9	5NO	15	7NO	21	9NO	27	GND	34
3Common	10	5Common	16	7Common	22	9Common	28	No Connect	17

Bank 2

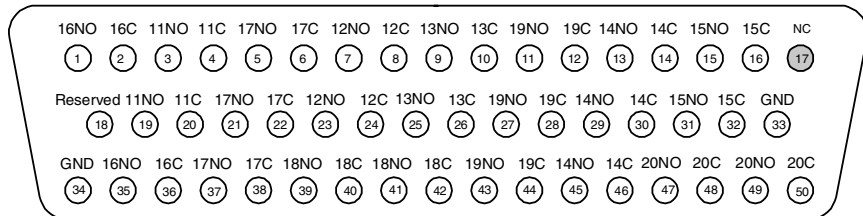

Channel	Pin	Channel	Pin	Channel	Pin	Channel	Pins	Channel	Pins
11NO	3	13NO	25	15NO	31	17NO	37	19NO	43
11Common	4	13Common	26	15Common	32	17Common	38	19Common	44
11NO	19	14NO	13	16NO	1	18NO	39	20NO	47
11Common	20	14Common	14	16Common	2	18Common	40	20Common	48
12NO	7	14NO	29	16NO	35	18NO	41	20NO	49
12Common	8	14Common	30	16Common	36	18Common	42	20Common	50
12NO	23	14NO	45	17NO	5	19NO	11	Reserved	18
12Common	24	14Common	46	17Common	6	19Common	12	GND	33
13NO	9	15NO	15	17NO	21	19NO	27	GND	34
13Common	10	15Common	16	17Common	22	19Common	28	No Connect	17

34938T Terminal Block

This terminal block with screw-type connections is labeled with the model number and the abbreviated module name. In addition, space is available on the label for you to write the slot number.

The 34980A Product Reference CD (shipped with the instrument) contains a the 34938T Wiring Log for you to document your wiring configuration for this module. You can open the wiring log file in Microsoft® Excel® or Adobe® Acrobat® format.

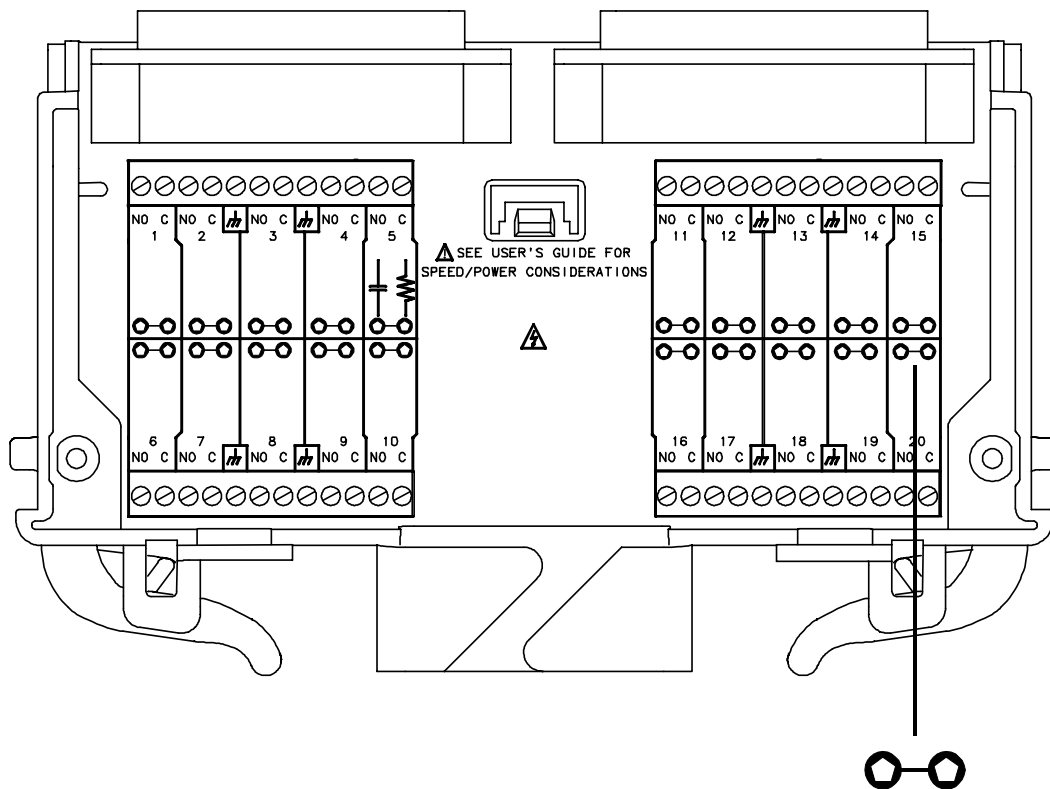

Pads for user-supplied snubber circuitry to alleviate reactive transients. The circuits may consist of resistors, capacitors, varistors, or other elements as needed to reduce the switching voltage and current transients inherent in reactive circuits.

6 General Purpose Switch Modules

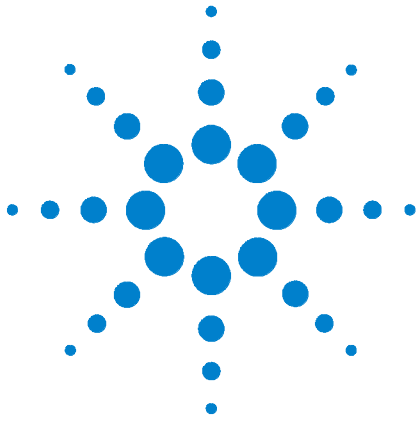

7 RF Multiplexer Switch Modules

34941A and 34942A RF Multiplexer Switch Modules [176](#)

Installing SMA Connectors [177](#)

Isolating Connector Banks [177](#)

34941A and 34942A SCPI Programming Examples [178](#)

34941A and 34942A Simplified Schematic [179](#)



34941A and 34942A RF Multiplexer Switch Modules

The 34941A and 34942A Quad 1x4 RF MUX switch modules provide high density RF signal switching with four independent 1x4 multiplexer banks in each module.

The important differences between the two RF MUX modules lie in their characteristic impedance and their use of connectors. The 34941A, the 50- Ω version, uses SMA connectors. The 34942A, the 75- Ω variation, uses Mini SMB connectors.

Both the 34941A and 34942A modules contain four banks of latching switches. Each bank consists of three form C relays. See the simplified schematic on [page 179](#).

The RF MUX modules do not connect to the analog buses. Instead, all signal connections are made through the visible connectors via external cables. Each visible connector on an RF MUX module is labeled with a number (11 through 44) that represents a channel you can close program a tic ally, from the front panel, or with the Web UI. When you close a channel on the RF MUX modules you automatically close all relays that create a direct path to the Common of a bank.

With RF MUX switches, you cannot open switches program a tic ally. You can only close a channel. When you close one channel, another channel automatically opens. Therefore, only one channel relay in each bank is closed at any time.

Each bank is chassis-grounded. Alternatively, you can easily isolate a bank from other banks and from chassis ground as well. Refer to [page 177](#) for instructions to install insulating washers.

You can connect the banks in this modules and to banks in other RF MUX modules to create a larger switching configuration. For example, you can create up to 1x97 RF MUX in a single 34980A mainframe.

Installing SMA Connectors

When installing SMA connectors on the 34941A module, it is recommend that you tighten them to 0.8 - 1.1 Nm (7-10 in-lbs) of torque.

CAUTION

SMA connectors are easily damaged, especially when tightening a neighboring connector with a wrench. To help prevent damage and contamination, do not remove a connector's protective cap until immediately prior to installing a cable on that connector.

Isolating Connector Banks

You can configure each bank on the RF MUX modules to be either isolated or chassis-grounded. The modules come with chassis-grounded metal shoulder washers installed on all connectors in each bank of relays. If you want to isolate a bank from the other banks and from chassis-ground, you must remove the five metal washers in that bank and replace them with the provided plastic shoulder washers.

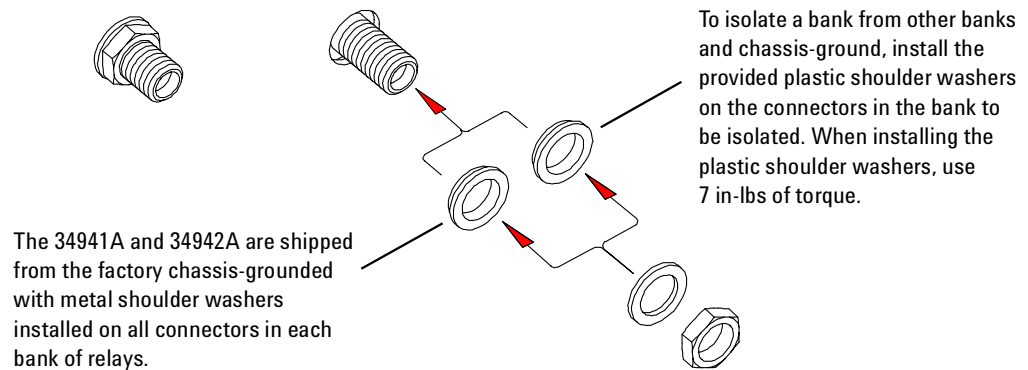

34941A and 34942A SCPI Programming Examples

The programming examples below provide you with SCPI command examples to use for actions specific to the RF MUX switch modules.

The slot and channel addressing scheme used in these examples follow the form **sccc** where **s** is the mainframe slot number (1 through 8) and **ccc** is the channel number. For information on specific configurations, refer to the simplified schematic on [page 179](#).

For complete information on the SCPI commands used to program the 34980A, refer to the Agilent 34980A Programmer's Reference contained on the 34980A Product Reference CD. For example programs, also refer to the 34980A Product Reference CD.

Example: Closing channels You can only close channels on the RF MUX modules. You cannot open channels. When you close a channel, any already-closed channels automatically open. With this “one-step” operation, the relays switch in the proper order that avoids momentary connection of the wrong input to the multiplexer output. The following command closes channel 03 on Bank 1 of an RF MUX module installed in slot 5.

```
ROUTE:CLOSE (@5103)
```

Example: Querying channels for open or close state The following commands returns the close or open state of channel 33 of a module installed in slot 5.

```
ROUT:CLOSE? (@5033)
ROUT:OPEN? (@5033)
```

Example: Querying the system for module identify The following command returns the identify of the module installed in slot 7.

```
SYSTEM:CTYPE? 7
```

Example: Reading the cycle count for a relay On these modules, the signal path to the COM terminal consists of two relays. See the simplified schematic on [page 179](#). For each path, the module stores the cycle count for both relays, and returns the *greater* of the two. The cycle count for the two channels within the same physical relay package (as indicated by the dashed lines in the simplified schematic) will always be equal. Therefore, the cycle count for Channels 101 and 102 will always be equal. The following statement reads back the number of completed cycles for the channels 101 and 202 on a module installed in slot 6.

```
DIAGnostic:RELAy:CYCLes? (@6101,6202)
```

Example: Clearing the cycle count for a relay The following command resets the cycle count on the channels 103 and 201 for a module in slot 1.

```
DIAGnostic:RELay:CYCLes:CLear (@1103,1201)
```

Example: Resetting module to power-on state The following command resets a module in slot 4 to its power-on state.

```
SYSTem:CPON 4
```

34941A and 34942A Simplified Schematic

Both the 34941A and 34942A modules are configured alike. They each contain four banks of latching switches. Each bank consists of three form C relays.

The front panel of the two RF MUXmodules are similar with channel labels in the same positions, the unique product number on the left, and the product description on the right.

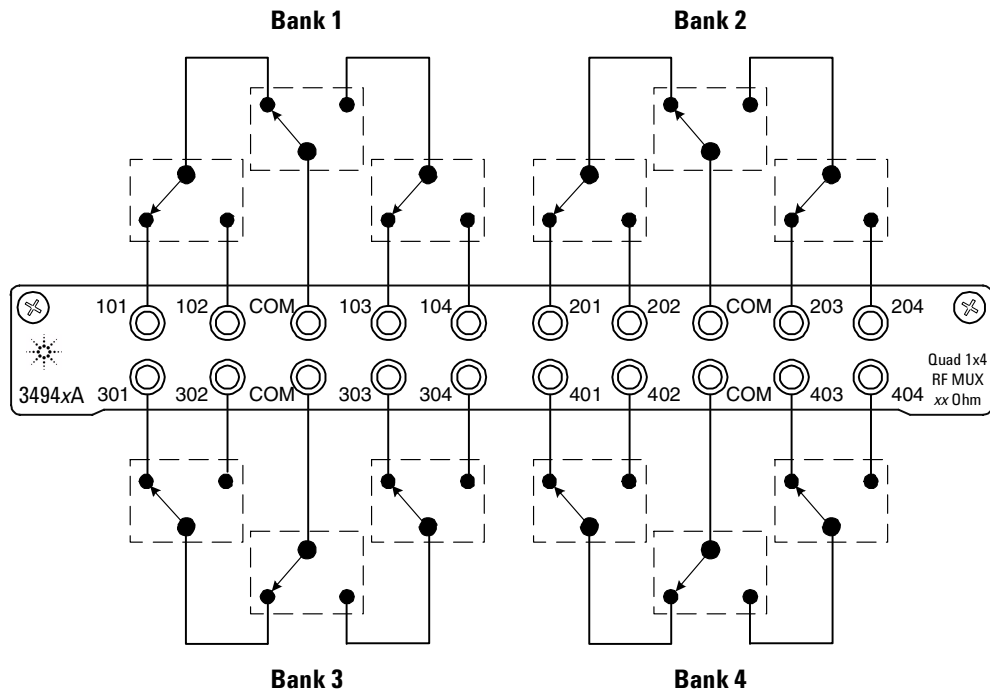

7 RF Multiplexer Switch Modules

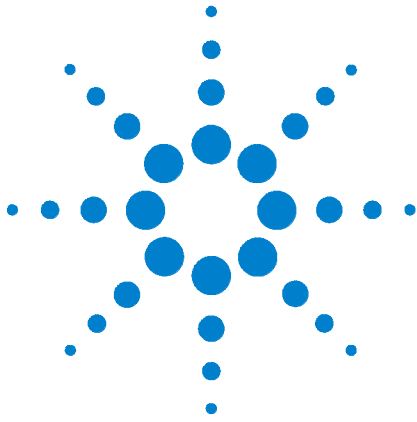

8

Dual/Triple Microwave Switch Modules

34946A and 34947A Dual/Triple Microwave Switch Modules [182](#)

Installing SMA Connectors [183](#)

34946A and 34947A SCPI Programming Examples [182](#)

34946A and 34947A Simplified Schematics [184](#)



34946A and 34947A Dual/Triple Microwave Switch Modules

The 34946A and 34947A modules offer single-pole, double-throw switches in either 4-GHz or 20-GHz options.

The 34946A and 34947A modules do not connect to the analog buses. Instead, all connections are made through the visible SMA connectors via external cables. Each connector on the modules is labeled with a three-digit number that represents a channel you can control programatically, from the front panel, or with the Web UI.

The 34946A module uses two independent Agilent N1810TL switches. These terminated 3-port 50-ohm switches are designed to maintain impedance matching. The 34947A module contains three independent Agilent N1810UL switches. These higher density 3-port switches are unterminated. For channel configuration on each module, refer to the simplified schematics on [page 184](#).

34946A and 34947A SCPI Programming Examples

The programming examples below provide you with SCPI command examples to use for actions specific to the microwave switch modules.

The slot and channel addressing scheme used in these examples follow the form `sccc` where `s` is the mainframe slot number (1 through 8) and `ccc` is the three-digit channel number. For information on specific configurations, refer to the simplified schematics in this chapter.

For complete information on the SCPI commands used to program the 34980A, refer to the Agilent 34980A Programmer's Reference contained on the 34980A Product Reference CD. For example programs, also refer to the 34980A Product Reference CD.

Example: Closing channels You can use the `ROUTE:CLOSE` to close channels on the microwave switch modules, but these modules do not support the `ROUTE:OPEN` command. You can open channels by closing other channels. With this “one-step” operation, the relays switch in the proper order that avoids momentary connection of the wrong input to the switch output. The following statement closes channel 201 of a microwave switch module installed in slot 5.

```
ROUTE:CLOSE (@5201)
```

Example: Querying channels for open or close state The following command returns the open (1) or close (0) state of channel 202 for a module in slot 3.

```
ROUTE:CLOSE? (@3202)
```

Example: Querying the system for module identify The following command returns the identify of the module installed in slot 7.

```
SYSTem:CTYPe? 7
```

Example: Reading the cycle count for a relay The following command reads back the number of completed cycles for the channel 201 relay of a module installed in slot 6.

```
DIAGnostic:RELAy:CYCLes? (@6201)
```

Example: Clearing the cycle count for a relay The following command resets the cycle count on the channels 201 and 202 for a module in slot 1.

```
DIAGnostic:RELAy:CYCLes:CLEar (@1201,1202)
```

Example: Resetting Module(s) to Power-On State The following command resets a module in slot 4 to its power-on state.

```
SYSTem:CPON 4
```

Installing SMA Connectors

When installing SMA connectors, it is recommend that you tighten them to 0.8 - 1.1 Nm (7-10 in-lbs) of torque.

34946A and 34947A Simplified Schematics

The following drawings show the channel configuration for the 34946A and 34947A modules, respectively.

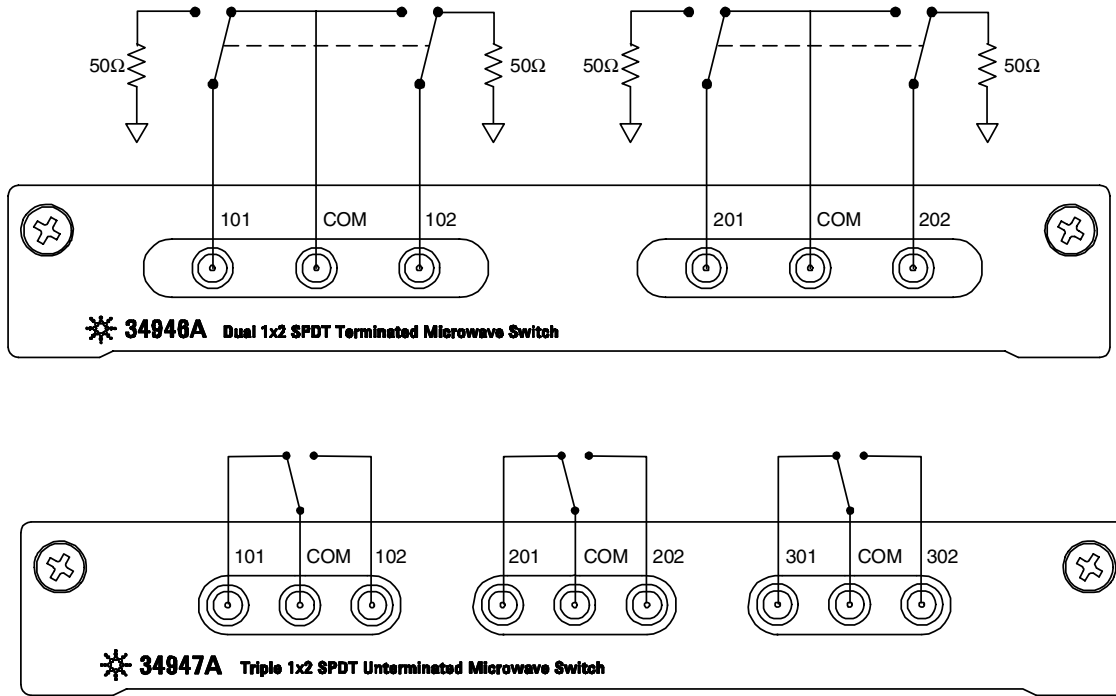



9

4-Channel Isolated D/A Converter with Waveform Memory Module

34951A 4-Channel Isolated D/A Converter with Waveform Memory
Module [186](#)

34951A SCPI Programming Examples [189](#)

34951A Simplified Schematics [193](#)

34951A D-Sub Connector Pinout [194](#)

34951T Terminal Block [195](#)



34951A 4-Channel Isolated D/A Converter with Waveform Memory Module

The 34951A 4-Ch Isolated D/A module (DAC module) has four independent, isolated DAC channels that output DC voltage up to $\pm 16\text{V}$ or DC current up to $\pm 20\text{ mA}$. Since the DACs are electrically isolated, you can stack or combine multiple DACs to have up to $\pm 64\text{ V}$ on a module. You can control each channel manually, or use the onboard memory to store multiple sequenced points.

Level Output Mode

The module can generate voltages between -16 V DC and $+16\text{ v DC}$ at $500\text{ }\mu\text{V}$ resolution on any or all four channels. Each channel configured for voltage output has hardware remote-sensing capability to ensure that an accurate voltage is present at the load. With the remote sensing feature, the DAC channel outputs an additional voltage to compensate for the voltage drop in the test leads. Thus, using the sense connections, the load voltage equals the programmed voltage as long as the resistance in each sense lead is less than 2.5Ω and the maximum voltage drop in the output leads is 0.5 volts .

NOTE

To ensure that an accurate voltage is present at the loads, it is recommended that you use remote-sensing. However, if remote-sensing is not used, do not connect loads or cables to the remote-sensing terminals (H Sense and L Sense).

When using the remote-sensing feature, connect sense wires from the load to the High Sense and Low Sense terminals for the desired channels.

Each channel can also generate current between -20 mA and $+20\text{ mA}$ at 630 nA resolution. When outputting current the High Sense and Low Sense terminals are not used and are opened. For protection, each channel incorporates a fuse that will open at greater than 20 mA . If an overload condition exists, the fuse will open, but no error or SRQ will be generated. To reset the fuse, remove the overload and wait a few minutes for the fuse to cool.

Waveform (Trace) Mode

Using the internal waveform point storage, you can output provided sine, square, or ramp and triangle wave shapes, or define your own wave shape with up to $512,000$ points. The module can output points with a settling time of $40\text{ }\mu\text{s}$ and a 200 kHz point-to-point update rate.

The on-board memory provides storage for you to create up to 32 voltage or current waveforms. You can apply a different waveform to each channel to output. Or you can apply the same waveform to more than one channel. For each channel you can designate the gain, frequency, and/or offset for its output.

The waveforms are stored in volatile memory. Therefore, whenever power to the 34980A is cycled, the volatile memory empties of data it has contained.

The waveform feature of the 34951A is not intended as a full-featured substitute for a function generator, but as a means of storing point-to-point updates.

Clock In

You can configure each DAC channel on the module to synchronize off either an internally-generated 20 MHz clock or the positive edge of an external user-supplied clock.

An external clock must be less than 10 MHz or indeterminate behavior will result. Additionally, as the maximum point-to-point update rate of the DACs is 200 kHz, if you configure a DAC to run off an external clock, you will need to ensure that the correct clock divisor is also configured for that DAC. For example, if you supply a 10 MHz external clock, the minimum clock divisor is 50 because the maximum update rate is 200 kHz. If a clock divisor less than the minimum is configured, indeterminate behavior will result. Thresholds for the Clock In are 5 V TTL tolerant.

Clock Out

There is one clock output on the DAC module, which you can configure to output at frequencies up to 10 MHz. Since it uses a 16-bit clock divisor, the available output frequencies range in steps of $20 \text{ MHz}/2^{16}$ with a minimum output frequency of 305 Hz. The output impedance of the Clock Out is 50 Ω .

NOTE

The line between external Clock Out and external Clock In is shared. You can use the external Clock Out to provide the external Clock In signal. However, both a user-supplied external clock and the module's Clock Out cannot drive the line at the same time.

Trigger In

You can configure each DAC on the module to trigger off an externally provide Trigger In that has a pulse width greater than 100 ns. The Trigger In line is 5V TTL tolerant.

Trigger Out

The DAC module can source a TTL level Trigger Out. Trigger Out has a pulse width between 5 and 10 μs .

NOTE

The line between external Trigger Out and external Trigger In is shared. You can use the external Trigger Out to provide the external Trigger In signal. However, both a user-supplied external trigger and the 34951A Trigger Out cannot drive the line at the same time.

Auto-Calibration

The 34951A features auto-calibration (auto-cal). Upon receipt of the CALibration:MODule? command, you can adjust all four channels of the DAC module. The adjustments, performed under complete control of the 34980A, require approximately one minute per module.

WARNING

Because the auto-cal uses the internal DMM, do not route signals on ABus1 when performing an auto-cal of a DAC module. Do not apply a signal to ABus1 via the Analog Bus connector on the rear of the mainframe (pins 4, 5, and 9). The auto-cal will abort if a signal is detected on ABus1.

Before performing an auto calibration, be sure to allow a one-hour warm-up of the DMM and 34951A module. The adjustment is valid for 90 days for temperatures within 5 °C of the auto-cal temperature. For the calibration constants to be saved, calibration security must be off. Otherwise, the new calibration constants can be used while power is on. But when power is lost, the DAC module will revert to using the previously stored calibration constants. For SCPI programming examples for the auto-cal, refer to [page 191](#).

34951A SCPI Programming Examples

The programming examples below provide you with SCPI command examples to use for actions specific to the DAC module.

The slot and channel addressing scheme used in these examples follow the form **sccc** where **s** is the mainframe slot number (1 through 8) and **ccc** is the three-digit channel number. Valid channels for this module are 1-4. For information on specific configurations, refer to the simplified schematic on [page 193](#).

For complete information on the SCPI commands used to program the 34980A, refer to the Agilent 34980A Programmer's Reference contained on the 34980A Product Reference CD. For example programs, also refer to the 34980A Product Reference CD.

Level Mode

Example: Outputting a DC voltage level This command sets the output voltage level for the specified DAC channels. After setting the desired level, send the `OUTPut:STATe` command to close the corresponding output relay and enable outputs from the specified channels. The following command outputs +2.5 V DC on DAC channels 1 and 2 for a module in slot 4.

```
SOURce:VOLTage 2.5, (@4001,4002)
OUTPut:STATe ON, (@4001,4002)
```

Example: Outputting a current level This command sets the output current level on the specified channels on the DAC module. After setting the desired level, send the `OUTPut:STATe` command to close the corresponding output relay and enable outputs from the specified channels. The following command outputs +5 mA on DAC channels 1 and 2 for a module in slot 4 and closes the output relay.

```
SOURce:CURRent 5E-3, (@4001,4002)
OUTPut:STATe ON, (@4001,4002)
```

Waveform Mode

Example: Downloading a waveform to memory and outputting waveform from DACs The following command segment downloads a 1000-point sine waveform to memory on the module in slot 4 and outputs the waveform from DAC channels 1 and 2. The trace name is "TEST_SINE".

```
TRACe:FUNCTion 4,SINusoid, TEST_SINE, 1000
SOURce:FUNCTion:TRACe TEST_SINE, (@4001,4002)
OUTPut:STATe ON, (@4001,4002)
SOURce:FUNCTion:ENABle ON, (@4001,4002)
```

Example: Downloading trace points to memory and outputting waveform from DACs

The following command segment downloads seven trace points to memory on the module in slot 4 and output the waveform from DAC channels 1 and 2. The trace name is "NEG_RAMP".

```
TRACe:DATA 4,NEG_RAMP, 1, .67, .33, 0, -.33, -.67, -1
SOURce:FUNCTion:TRACe NEG_RAMP, (@4001,4002)
OUTPut:STATe ON, (@4001,4002)
SOURce:FUNCTion:ENABle ON, (@4001,4002)
```

Example: Setting the amplitude of a waveform for offset and gain

The following commands set the offset to 5.25 and the gain to 1.5 on DAC channels 1 and 2 of a module in slot 4.

```
SOURce:FUNCTion:VOLTagE:OFFSet 5.25, (@4001,4002)
SOURce:FUNCTion:VOLTagE:GAIN 1.5, (@4001,4002)
```

Example: Setting cycle count for a waveform The following command segments turn off the trace output mode on DAC channels 1 and 2 in slot 4, set the cycle count to 100, then turn the trace output mode back on.

```
SOURce:FUNCTion:ENABle OFF, (@4001,4002)
SOURce:FUNCTion:TRACe:NCYCles 100, (@4001,4002)
SOURce:FUNCTion:ENABle ON, (@4001,4002)
```

Example: Deleting a waveform The following command deletes the trace named "TEST_WFORM" from the module in slot 4.

```
TRACe:DELeTe 4,TEST_WFORM
```

External Clock

Example: Selecting an external clock source and setting a clock divisor The first command selects the external clock source on DAC channels 1 and 2 in slot 4. The external clock input is shared between these two channels. The second command sets the clock divisor to 100 on the same DAC channels (the external clock input signal is divided by 100).

```
SOURce:FUNCTion:CLOCK:SOURce EXTernal, (@4001,4002)
SOURce:FUNCTion:CLOCK:EXTernal:DIVisor 100, (@4001,4002)
```

Example: Outputting a clock The following commands set the clock output frequency for slot 4 to 5 kHz and enable the output.

```
SOURce:MODule:CLOCK:FREQuency 5E+3,4
SOURce:MODule:CLOCK:STATe ON,4
```

External Trigger

Example: Selecting the external trigger source and issuing trigger source The following command segment enables the trigger output mode on a DAC module installed in slot 4, then enables the external trigger source on DAC channels 1 and 2. The last command issues an external trigger pulse from the module.

```
SOURce:MODule:TRIGger:OUTPut ON,4
SOURce:FUNCTion:TRIGger:SOURce EXTernal,(@4001,4002)
SOURce:MODule:TRIGger:EXTernal:IMMediate 4
```

Auto Calibration

Example: Performing an auto calibration on all DAC channels This command performs an auto-cal of all four channels on a DAC module. Because the auto-cal takes can take up to one minute per DAC channel, you may want to increase the time-out value of your programming application prior to sending this command.

The following command performs an auto-cal of a DAC module in slot 5 and returns a pass/fail indication.

```
CALibration:MODule? 5
```

The following command performs an auto-cal of all 34951A DAC modules in a mainframe.

```
CALibration:MODule? ALL
```

Example: Effects of using the secure state command on storing calibration constants

The following command removes instrument security, and the calibration constants are stored in non-volatile memory if sent before the CALibration:MODule? command.

```
CALibration:SECure:STATE OFF <security code>
```

If the instrument is secured at the time of auto-cal, the calibration constants are stored in volatile memory and are lost when power is turned off. The *RST command will not discard the calibration constants. The command to secure the instrument is:

```
CALibration:SECure:STATE ON <security code>
```

NOTE

The default security code is AT34980.

Configuring a DAC Module

Example: Querying the system for module identify (all modules) The following command returns the identify of the module installed in slot 7.

```
SYSTem:CTYPE? 7
```

Example: Resetting the module(s) to power-on state The following command resets a module in slot 4 to its power-on state.

```
SYST:CPON 4
```

NOTE

Using this command will erase any downloaded waveforms.

34951A Simplified Schematics

The following schematic shows how the module is generally configured.

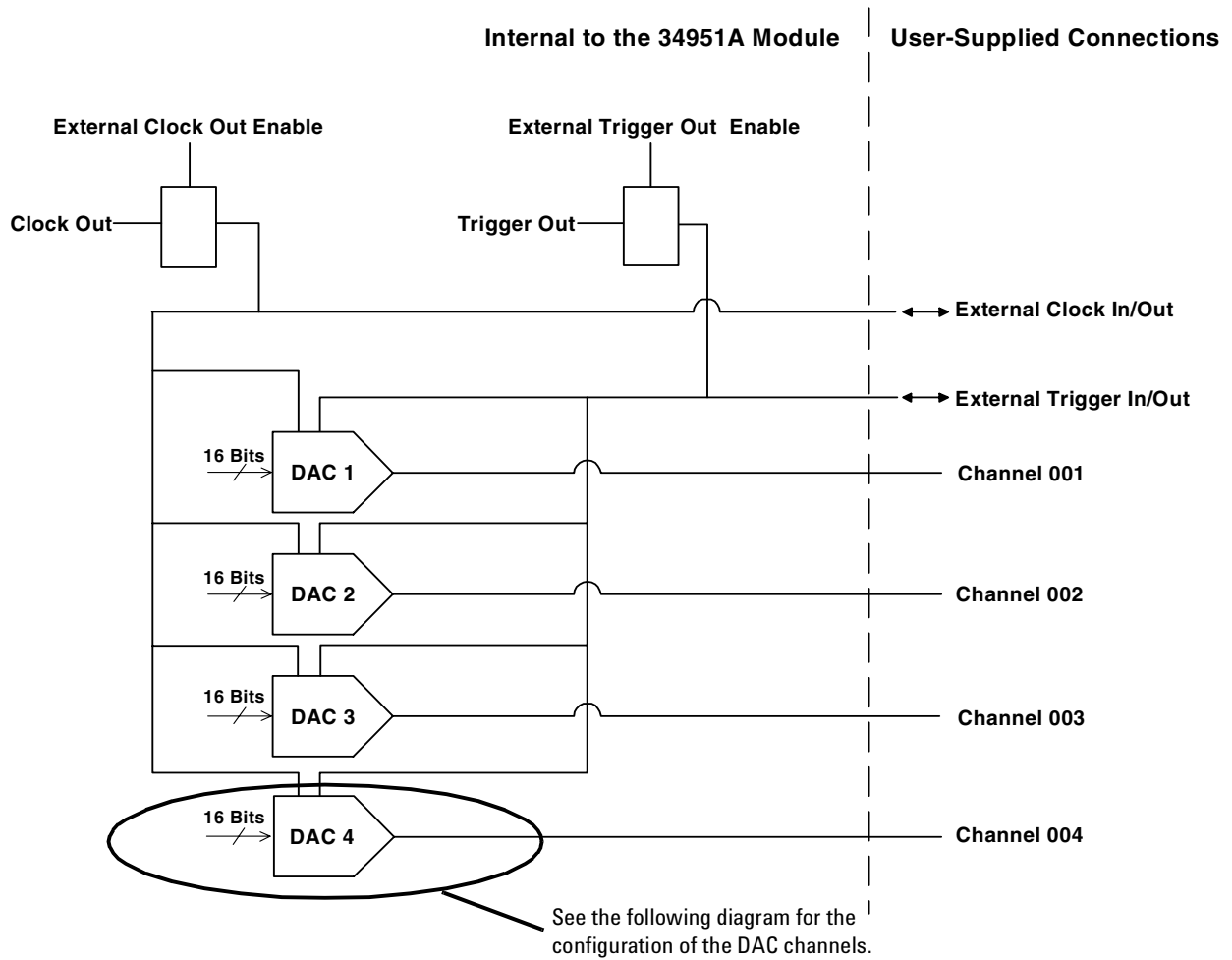

9 4-Channel Isolated D/A Converter with Waveform Memory Module

The following diagram shows individual DAC channel configuration. All channels are configured the same.

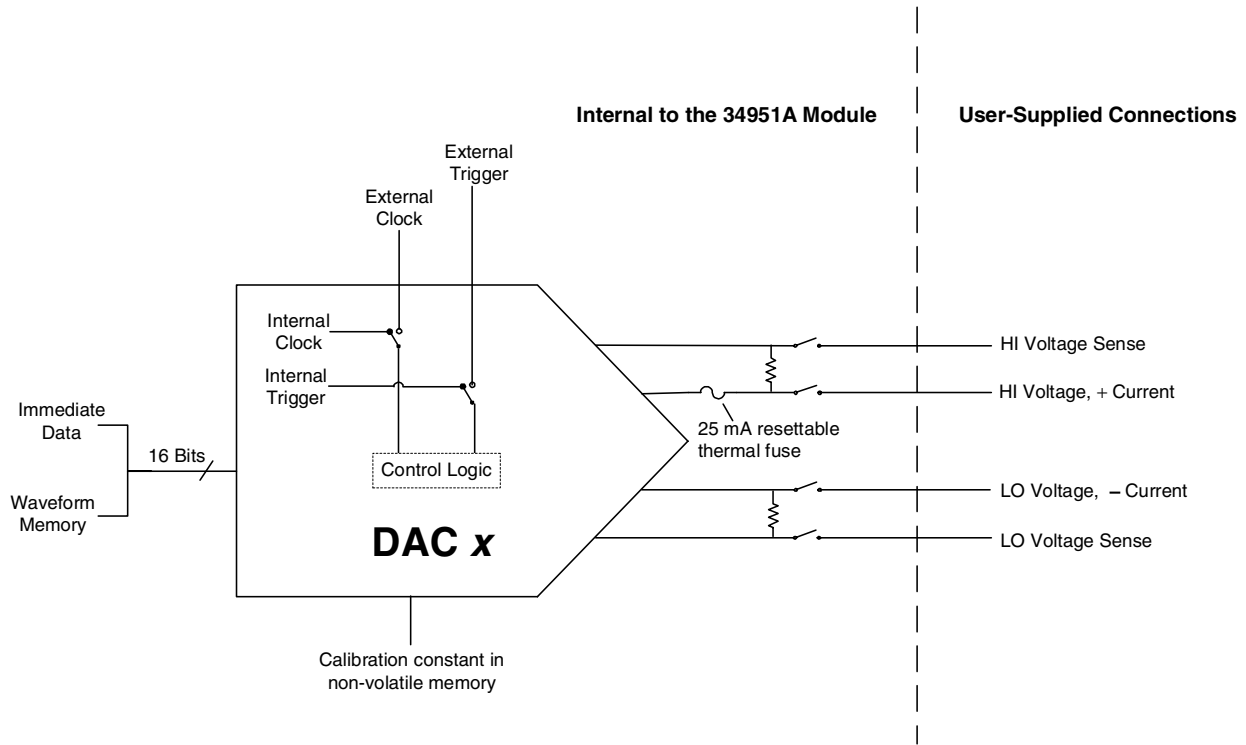

34951A D-Sub Connector Pinout

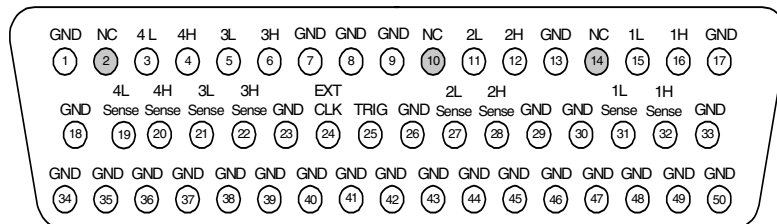

Description	Pin	Description	Pin	Description	Pin	Description	Pin	Description	Pin
1L	15	3L Sense	21	GND	8	GND	34	GND	44
1H	16	3H Sense	22	GND	9	GND	35	GND	45
1L Sense	31	4L	3	GND	13	GND	36	GND	46
1H Sense	32	4H	4	GND	17	GND	37	GND	47
2L	11	4L Sense	19	GND	18	GND	38	GND	48
2H	12	4H Sense	20	GND	23	GND	39	GND	49
2L Sense	27	External Clock	24	GND	26	GND	40	GND	50
2H Sense	28	Trigger	25	GND	29	GND	41	No Connect	2
3L	5	GND	1	GND	30	GND	42	No Connect	10
3H	6	GND	7	GND	33	GND	43	No Connect	14

34951T Terminal Block

Each terminal block is labeled with the model number and the abbreviated module name. In addition, space is available on the label for you to write the slot number.

The 34980A Product Reference CD (shipped with the instrument) contains a the 34951T Wiring Log for you to document your wiring configuration for this module. You can open the wiring log file in Microsoft® Excel® or Adobe® Acrobat® format.

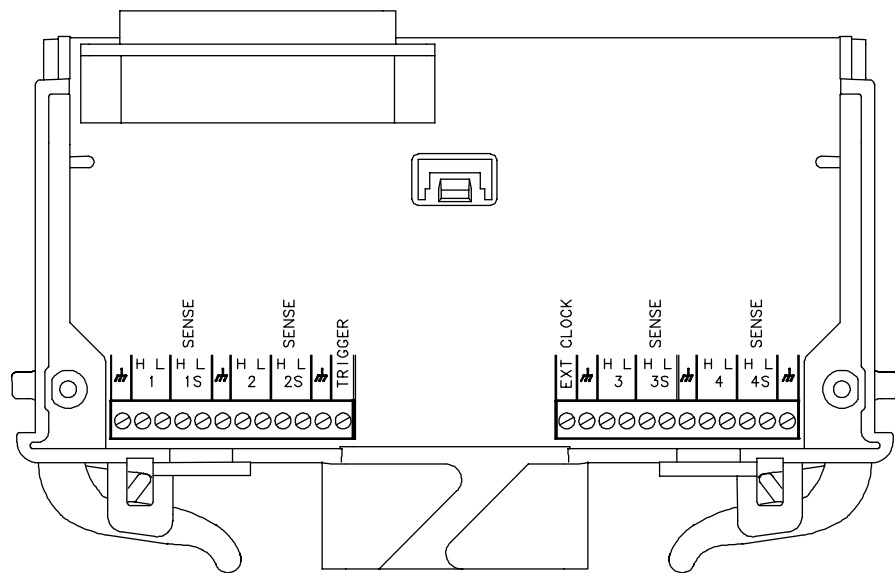

9 4-Channel Isolated D/A Converter with Waveform Memory Module

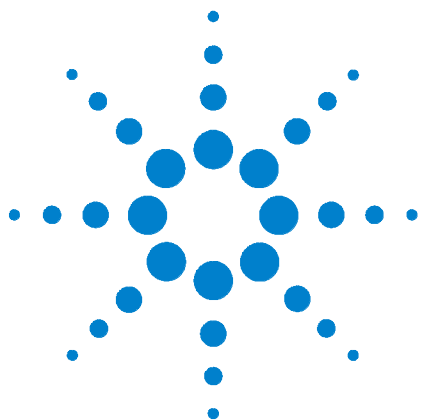

10 Multifunction Module with DIO, D/A, and Totalizer

34952A Multifunction Module	198
34952A SCPI Programming Examples	199
34952A Simplified Schematic	201
34952 D-Sub Connector	202
34952T Terminal Block	203



34952A Multifunction Module

The 34952A Multifunction Module with DIO, D/A, and Totalizer combines four 8-bit ports of digital input/output, a 100 kHz totalizer, and two ± 12 volt earth-referenced analog outputs. You can include digital inputs and totalizer input in a scan list. You can make connections via standard 50-pin D-sub cables or the optional 34952T terminal block.

Digital Input/Output

The Digital Input/Output (DIO) consists of four 8-bit ports with TTL-compatible inputs and output. The open-drain outputs can sink up to 400 mA. From the front panel, you can read data from only one 8-bit input port at a time. You can configure the DIO ports for 8, 16, or 32-bit operations. The DIO channels are connected by internal 5 V pull-up resistors when configured as inputs.

Totalizer Input

The 32-bit totalizer can count pulses at a 100 kHz rate. You can configure the totalizer to count on the rising edge or falling edge of the input signal. A TTL high signal applied to the Not-Gate terminal enables counting and a low signal disables counting. A TTL low signal applied to the Not-Gate terminal enables counting and a high signal disables counting. The totalizer counts only when both terminals are enabled.

NOTE

When a gate is not connected, the gate terminal is pulled to the enabled state, effectively creating a “gate always” condition.

Analog Output (DAC)

The two analog outputs are capable of outputting voltages between ± 12 volts with 16 bits of resolution. Each DAC channel is capable of 10 mA maximum current. Use the two analog outputs to source bias voltages to your DUT, to control your analog programmable power supplies, or as set points for your control systems. The outputs are programmed directly in volts.

34952A SCPI Programming Examples

The programming examples below provide you with SCPI command examples to use for actions specific to the general purpose switch modules.

The slot and channel addressing scheme used in these examples follow the form **sccc** where **s** is the mainframe slot number (1 through 8) and **ccc** is the channel number. For information on specific configurations, refer to the simplified schematic on [page 201](#).

For complete information on the SCPI commands used to program the 34980A, refer to the Agilent 34980A Programmer's Reference contained on the 34980A Product Reference CD. For example programs, also refer to the 34980A Product Reference CD.

Digital Input/Output

Example: Configuring a DIO channel The following program segment configures channel 1 on the DAC module in slot 3 as an output and then reads the output value (the channel is not reconfigured as an input). Then, the channel is reconfigured as an input and the value is read again.

The second command below returns 64 as it is physically reading the output data.

```
SOURCE:DIGital:DATA:BYTE 64, (@3001)
SENSE:DIGital:DATA:BIT? 0, (@3001)
```

The second command below returns whatever is being input externally.

```
CONFIGure:DIGital:STATE INPut, (@3001)
SENSE:DIGital:DATA:BIT? 0, (@3001)
```

Totalizer

Example: Reading totalizer channel count The following command reads the count on totalizer channel 5 on the Multifunction module in slot 3.

```
SENSE:TOTAlize:DATA? (@3005)
```

Example: Configuring the totalizer reset mode To configure the totalizer reset mode, send either of the following commands.

The following command configures totalizer channel 5 on the Multifunction module in slot 3 to be read without resetting its count.

```
SENSE:TOTAlize:TYPE READ, (@3005)
```

The following command configures totalizer channel 5 on the Multifunction module in slot 2 to be reset to "0" after it is read (RRESet means "read and reset").

```
CONFigure:TOTalize RRES, (@2005)
```

Example: Configuring the totalizer for count This command configures the totalizer to count on the rising edge (positive) or falling edge (negative) of the input signal. The following command configures the totalizer (channel 5) on a Multifunction module in slot 3 to count on the negative edge (falling) of the input signal.

```
TOTALize:SLOPe NEGative, (@3005)
```

Example: Clearing count on the totalizer channel This command immediately clears the count on the specified totalizer channels. The following command clears the count on the totalizer (channel 5) on a Multifunction module in slot 3.

```
TOTALize:CLEAR:IMMediate (@3005)
```

DAC Output

Example: Setting output voltage This command sets the output voltage level for the specified DAC channels. The following command outputs +2.5 V DC on DAC channels (6 and 7) of a Multifunction module in slot 4.

```
SOURce:VOLTage 2.5, (@4006,4007)
```

Configuring a Multifunction Module

Example: Querying the system for module identify The following command returns the identify of the module installed in slot 7.

```
SYSTem:CTYPe? 7
```

Example: Resetting module(s) to power-on state The following command resets a module in slot 4 to its power-on state.

```
SYSTem:CPON 4
```

34952A Simplified Schematic

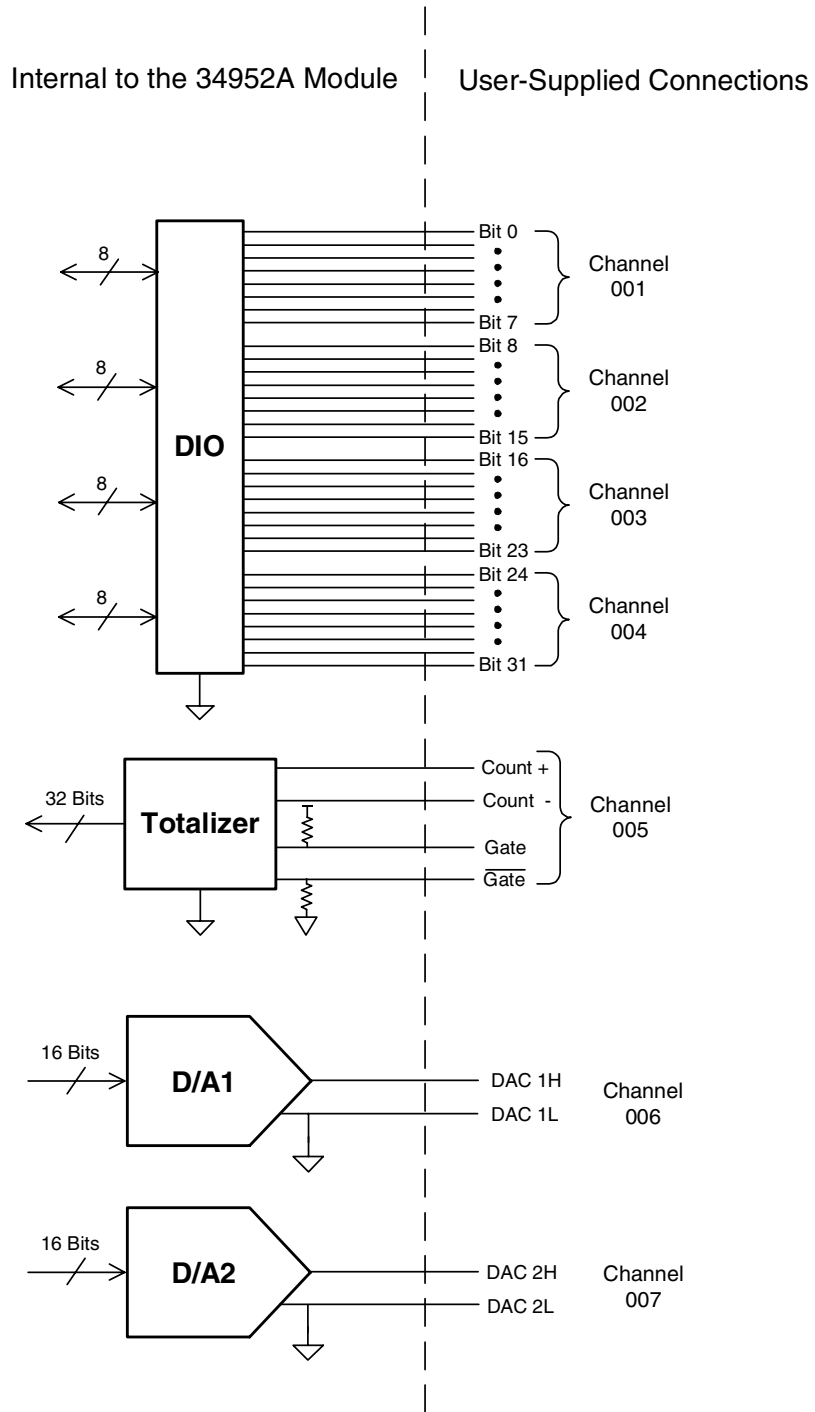

34952 D-Sub Connector

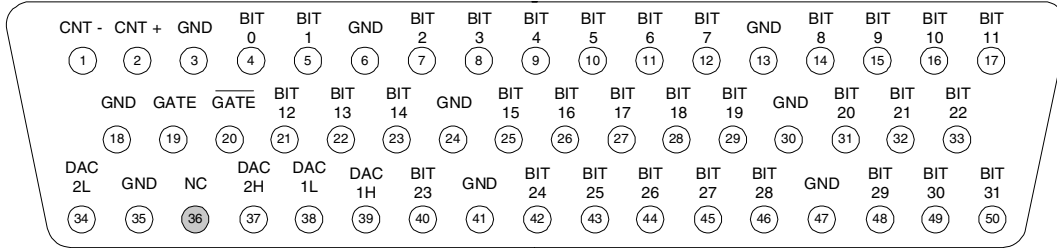

Description		Pin	Description		Pin	Description		Pin	Description		Pin
Channel 1	Bit 0	4	Channel 3	Bit 16	26	Channel 5 Totalizer	Count -	1	GND	47	
	Bit 1	5		Bit 17	27		Count +	2	No Connect	36	
	Bit 2	7		Bit 18	28		Gate	19			
	Bit 3	8		Bit 19	29		Not-Gate	20			
	Bit 4	9		Bit 20	31	Channel 6	DAC 1L	38			
	Bit 5	10		Bit 21	32		DAC 1H	39			
	Bit 6	11		Bit 22	33	Channel 7	DAC 2L	34			
	Bit 7	12		Bit 23	40		DAC 2H	37			
Channel 2	Bit 8	14	Channel 4	Bit 24	42		GND	3			
	Bit 9	15		Bit 25	43		GND	6			
	Bit 10	16		Bit 26	44		GND	13			
	Bit 11	17		Bit 27	45		GND	18			
	Bit 12	21		Bit 28	46		GND	24			
	Bit 13	22		Bit 29	48		GND	30			
	Bit 14	23		Bit 30	49		GND	35			
	Bit 15	25		Bit 31	50		GND	41			

34952T Terminal Block

Each terminal block is labeled with the model number and the abbreviated module name. In addition, space is available on the label for you to write the slot number.

The 34980A Product Reference CD (shipped with the instrument) contains a the 34952T Wiring Log for you to document your wiring configuration for this module. You can open the wiring log file in Microsoft® Excel® or Adobe® Acrobat® format.

The 34952T provides space for breadboard and for a connector to control an external Opto-22 standard board.

